

**Site Preparation Guide for
E-Scan and Opera**

August 2006

The information contained in this Manual is confidential and proprietary to Hologic, Inc. This information is provided only to authorized representatives of Hologic's customers, solely for the purpose of facilitating the use of Hologic's products. No information contained herein may be disclosed to any unauthorized person, for any purpose whatsoever without the written consent of Hologic, Inc.

The information in this document is subject to change without notice.

Copyright 2006 by Hologic, Inc. All rights reserved.

C-Scan, Opera, and E-scan are the Trademarks of ESAOTE S.p.A.

The Hologic logo is a registered trademark of Hologic, Inc.

Printed in the U.S.A.

All trademarks, registered trademarks, and product names used within this document are the property of their respective owners.

Hologic, Inc.
35 Crosby Drive
Bedford, MA 01730
USA
Tel: (781) 999-7300
Fax: (781) 280-0669
MRI Service: (800) 537-3860

The Process

This guide provides information to help you prepare for the delivery and installation of an ESAOTE E-Scan Extremity MRI device. The process will begin when Hologic has received the signed Quotation back from you.

Steps in the Process

Each of the following steps is explained in detail below.

1. Room Selection
2. Site Test
 - a. Delivery Path
 - b. Environmental Control
 - c. Power Requirements
 - d. Interference Testing – Radio Frequency, AC and DC Magnetic Field Interference, Vibration
3. Floor Loading
4. Site Test Results Review
5. Delivery and Physical Installation
6. Calibration and Quality Assurance
7. Application Training

Responsibilities

Hologic will:

- Perform a site test on the primary, and secondary, room you have chosen for the MRI system.
- Evaluate the site test and prepare a Site Test Results document that will be reviewed with you.
- Inspect the room, and the delivery path to the room, to ensure the MRI system can be delivered and installed safely.
- Contract for delivery, uncrating and setting up your MRI system.
- Calibrate and test your MRI system.
- Provide operator training on your MRI system.

Your responsibilities are to:

- Select a primary, and secondary, room for your MRI system.
- Provide an architect's Floor Loading Certificate to Hologic.
- Ensure that the MRI room meets all environmental specifications including HVAC, plumbing, electrical, foundation, demolition/preparation, smoke detection, thermostat, concrete topping, and interior finishing work.
- Provide any professional engineers reviews or stamps, bonding fees, permits, licenses, union assistance, and dumpster for disposal of debris.

The installation of an Extremity MRI device at any site requires serious consideration

regarding space and site planning. A properly prepared site provides a comfortable working environment for the operator with proper access for the patient as well as providing a stable environment for the unit.

If you have specific questions or concerns not addressed here, please contact Hologic MRI Support at (800) 537-3860.

1. Room Selection

The first step in the process is to identify the room where the equipment will be installed. The following figure shows the minimum room dimensions and possible orientation of an ESAOTE E-Scan Extremity MRI device. The final orientation of the magnet in the room is dictated by environmental factors, such as RF interference, rather than by individual preference and will be determined by the results of the site test. We recommend that prior to site testing you select both a primary and secondary room for testing.

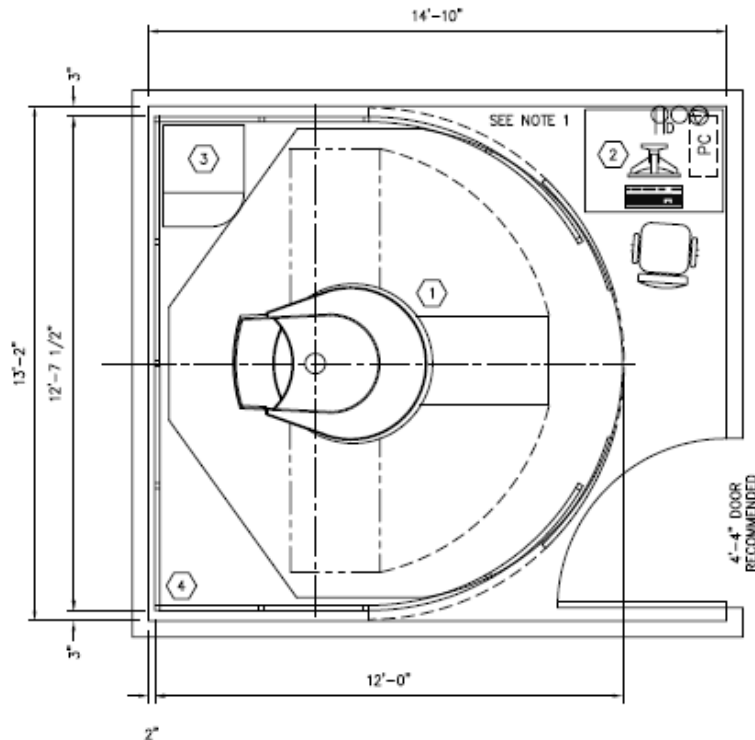

Figure 1-1. E-Scan/Opera with Standard Pavilion

Note: For proper operation of the E-Scan, the room dimensions must be at least 14 ft. 10 in. by 13 ft. 2 in. with a ceiling height of at least 7 ft. 10½ in.

Room sizes larger than that shown in the figure, and doorways wider than the 36 inch minimum, will simplify the installation, , operation, and servicing of the equipment.

Note: The minimum room dimensions assume there are no obstructions (sinks, counters, etc.) or outcroppings (pillars, etc.) within the room.

Any obstructions or outcroppings must be removed prior to installation of the equipment.

The E-Scan MRI operator's console is connected to the magnet by a 16 ft. data cable and is normally installed in the room with the E-Scan MRI.

1a. Lighting

Fluorescent lighting causes AC interference with the imaging system. Fluorescent light fixtures should be removed and replaced with Incandescent fixtures.

1b. Networking

Sending MRI studies to a Radiologist or Practice outside of your facility for reporting will require a network connection that has access to the Internet. A Cat 5 or higher network connection jack (RJ45) should be positioned near the CPU console. The recommended location will be included on the room drawings that will be provided prior to the installation date.

A networking hub may be required if a Network DICOM printer is to be installed in the same room as the Scanner CPU.

2. Site Test

A Field Engineer will be visiting your facility to take room size measurements and perform preliminary investigations of floor loading, delivery path and environmental controls. He will also be setting up electronic environmental testing equipment in the selected room(s).

2a. Delivery Path

The delivery path of the unit will be inspected to ensure that the magnet and components can be safely delivered to the room. This includes doorway and hallway widths, elevator ratings, truck parking, and floor loads.

***Note:** The Floor Loading Certificate provided to Hologic validating the area specified for the Magnet must also include that the delivery path and any elevators (if needed) are sufficient as well.*

2b. Environmental Control

Your ESAOTE E-Scan Extremity MRI device will operate at the following temperature and humidity levels:

Temperature	Max Temp Change	Relative Humidity
68° - 79° Fahrenheit	<5° F/hour	45% - 80%, non-condensing

Note : The air conditioner for the scan room must operate constantly. The temperature of the scan room must be maintained within the 68-79° Fahrenheit temperature range. The temperature cannot change by more than 5°F per hour. The software will disable the scanner should these conditions not be maintained.

It is recommended that the thermostat be in the room with the MRI scanner. This will assist in keeping the room temperature within specifications.

The ESAOTE E-Scan Extremity MRI device will add approximately 1400 BTU/hour to the air conditioning load of the room in which it is installed.

2c. Power Requirements

The power requirements for the ESAOTE E-Scan Extremity MRI device are as follows:

VOLTAGE (volts)	FREQUENCY (Hz)	CURRENT (Amperes)	MAXIMUM APPARENT LINE RESISTANCE (ohms)
120 VAC ± 10%	60	9.0	0.32

Note: A dedicated single-phase, grounded, electrical circuit is required. We also require a 20A Medical Grade outlet and associated wiring.

A line conditioning UPS will be provided with the system for protection of the CPU and magnet electronics.

2d. Interference Testing

A Hologic Field Service Engineer will set up test equipment that will run in the selected space for 24 hours. This Site Test will gather data on the RF, AC and DC magnetic qualities of the room. We require 24 hours of testing to provide a base line of data that shows the condition of the selected space when there is minimal interference (i.e. at night) and during normal business operation conditions. Therefore, testing must occur during the week and not over holidays or weekends.

RF Interference

Radio Frequency (RF) Interference may cause lines, bands, or spikes in the images acquired by an MRI scanner. The external RF noise must be no more than 40dB mV/m. RF interference will be determined during the MRI Site Test performed by the Hologic Field Engineer. This data will be used to determine the best magnet frequency for your site and whether any additional shielding will be required for your E-Scan Extremity MRI device to function properly.

Maximum Acceptable RF Interference
40dB mV/m

Magnetic Field Interference

Excessive DC interference will cause blurring of the image. Possible sources of DC interference include railroads, elevators and highways.

Excessive AC interference will cause multiple images to display (ghosting). Air conditioning/air handlers, power lines, improper wiring or grounds, and subways are possible sources of AC interference.

The Hologic Field Engineer will measure both the AC and DC interference levels at your site during testing. The values obtained will determine whether or not external compensation can be used to reduce interference to acceptable levels. The maximum values for AC and DC interference both with and without compensation are shown in the tables below.

Maximum Values without Magnetic Compensation needed	
DC (<5Hz)	0.3mG pk-pk
AC (60Hz)	0.2mG pk-pk
Maximum Values with Magnetic Compensation	
DC (<5Hz)	30mG pk-pk
AC (60Hz)	10mG pk-pk

Vibration

Building vibrations or shocks affecting the magnet may degrade image quality. The Vibrational Acceleration a_{max} must not exceed -70dB for a frequency range of 0 to 100Hz. Vibration testing will be completed during the site test.

Building Vibration Requirements	
a_{max}	-70dB from 0-100Hz

Should RF, magnetic interference or vibration levels be greater than the values specified above, a number of mitigations exist, your Hologic Sales Representative will discuss these with you. He or she will present you with various options to meet your site's particular needs.

3. Floor Loading

You will need to have an architect provide a floor loading certificate indicating that the floor and delivery path are capable of supporting the weight of the equipment. Floor loading in the scan room should take into account the weights of the MRI components and three persons.

Part	Width	Depth	Height	Weight
Magnet and Patient Table	50 in.	99 in.	62 in.	4630 lbs
Operators Console	43 in.	32 in.	30 in.	66 lbs
Electronics Cabinet	32 in.	25 in.	58 in.	463 lbs
Standard Pavilion	158 in.	144 in.	93 in.	1103 lbs

Total Floor Load Requirement
8554 Lbs

The floor must be level to within $3/16$ in. across 10 ft. Linoleum/Vinyl Tile Flooring is recommended. There can be no carpeting below the footprint of the RF cage. If the floor is found to be out of specification, suggestions will be provided to bring the floor into specification.

Allow clearance of at least 2 in. behind the Pavilion for ventilation and 3 in. between Pavilion sides and room walls for ventilation and cabling purposes.

As the customer, you and your contractor(s) will be responsible for any HVAC, plumbing, electrical, foundation, demolition/preparation, smoke detection, thermostat, concrete topping, and interior finishing work needed. Your contractor(s) will also be responsible for any professional engineers reviews or stamps, bonding fees, permits, licenses, union assistance, and dumpster for disposal of debris.

4. Site Test Results Review

Data collected and downloaded by the Field Engineer will be forwarded to a Hologic MRI site plan expert who will evaluate it and prepare the Site Test Results document. The Site Test Results document will be sent to your Sales Representative who will review the results with you.

5. Delivery and Physical installation

Delivery can occur only after all changes required to bring the room into compliance are completed.

Typically, delivery will begin on a Thursday morning. A third party employed by Hologic will uncrate, place and assemble the RF cage and E-Scan Extremity MRI unit. They will also connect the unit to power to begin the magnet heating process. The magnet will heat over the weekend so that it is at a stable, operational temperature for calibration.

The third party will be responsible for the removal of the empty crates and boxes.

6. Calibration and Quality Assurance Testing

The Hologic Field Engineer will arrive to calibrate and test the unit the Monday following the physical installation of the unit. Calibration and Quality Assurance testing will require 4-5 days.

7. Application Training

The Hologic MRI Application Trainer will arrive on the Monday following the calibration of the unit. Training will require 5 days. The Application Trainer will contact you during the week that Calibration and Quality Assurance Testing occurs.