

HOLOGIC®



ThinPrep® Review Scope

Operator's Manual



ThinPrep® Imaging System

**Review Scope
Operator's Manual**

HOLOGIC®



HOLOGIC, INC.
250 CAMPUS DRIVE
MARLBOROUGH, MA 01752 USA
TEL: 1-800-442-9892
1-508-263-2900
FAX: 1-508-229-2795
WEB: WWW.HOLOGIC.COM

For Use With Version 6.x.y Software

MAN-03352-001

The ThinPrep® Imaging System is a PC-based and automated review system for use with ThinPrep cervical cytology sample slides. The ThinPrep Imaging System is intended to help a cytotechnologist or pathologist highlight areas of a slide for further manual review. The Product is not a replacement for manual review. Determination of slide adequacy and patient diagnosis is at the sole discretion of the cytotechnologists and pathologists trained by Hologic to evaluate ThinPrep prepared slides. If and only if it is finally determined by a court of competent jurisdiction that the Product sold to Customer thereunder was defective in design or contained a manufacturing defect and that such defect was solely responsible for an error in diagnosis that caused harm to a patient, Hologic shall indemnify Customer for the compensatory damages paid by Customer to discharge the personal injury judgment with respect to Product.

Caution: Federal law restricts this device to sale by or on the order of a physician, or any other practitioner licensed by the law of the State in which the practitioner practices to use or order the use of the device and are trained and experienced in the use of the ThinPrep Imaging System.

© Hologic, Inc., 2017. All rights reserved. No part of this publication may be reproduced, transmitted, transcribed, stored in a retrieval system, or translated into any language or computer language, in any form, or by any means, electronic, mechanical, magnetic, optical, chemical, manual, or otherwise, without the prior written permission of Hologic, 250 Campus Drive, Marlborough, Massachusetts, 01752, United States of America.

Although this guide has been prepared with every precaution to ensure accuracy, Hologic assumes no liability for any errors or omissions, nor for any damages resulting from the application or use of this information.

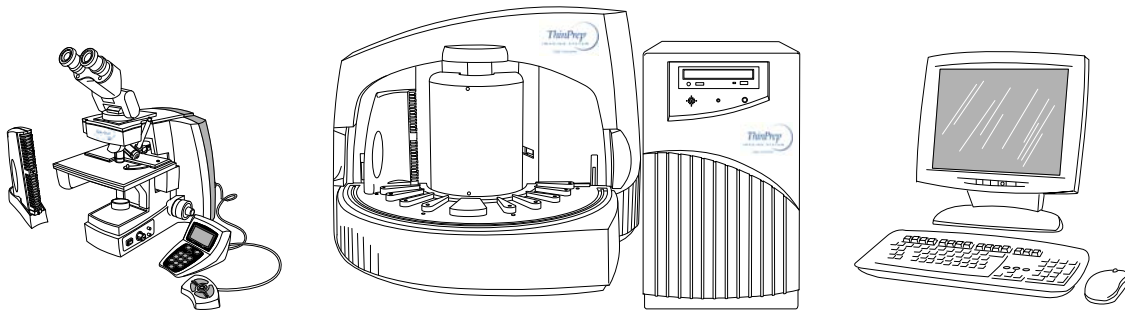
This product may be covered by one or more U.S. patents identified at <http://www.hologic.com/patentinformation/>

Hologic, PreservCyt and ThinPrep are registered trademarks in the United States and other countries. All other trademarks are the property of their respective companies.

Changes or modifications to this unit not expressly approved by the party responsible for compliance could void the user's authority to operate the equipment.



Operation Summary and Clinical Information



The ThinPrep® Imaging System

HOLOGIC®

A. INTENDED USE

The Hologic ThinPrep® Imaging System (Imager) is a device that uses computer imaging technology to assist in primary cervical cancer screening of ThinPrep Pap Test slides for the presence of atypical cells, cervical neoplasia, including its precursor lesions (Low Grade Squamous Intraepithelial Lesions, High Grade Squamous Intraepithelial Lesions), and carcinoma as well as all other cytologic criteria as defined by 2001 Bethesda System: Terminology for Reporting Results of Cervical Cytology ¹.

B. SUMMARY AND EXPLANATION OF THE SYSTEM

The ThinPrep Imaging System is an automated imaging and review system for use with ThinPrep Pap Test slides. It combines imaging technology to identify microscopic fields of diagnostic interest with automated stage movement of a microscope in order to locate these fields. In routine use, the ThinPrep Imaging System selects 22 fields of view for a Cytotechnologist to review. Following review of these fields, the Cytotechnologist will either complete the diagnosis if no abnormalities are identified or review the entire slide if any abnormalities are identified. The ThinPrep Imaging System also allows the physical marking of locations of interest for the Cytopathologist.

C. PRINCIPLES OF OPERATION

The ThinPrep Imaging System consists of an Image Processor and one, or more, Review Scopes. The system makes use of computer imaging to select fields of view for presentation to a Cytotechnologist on a Review Scope. Slides used with this system must first be prepared on a ThinPrep 2000 or 3000 Processor, and stained with ThinPrep Stain.

The Imaging Processor acquires and processes image data from the slides to identify diagnostically relevant cells or cell groups based on an imaging algorithm that considers cellular features and nuclear darkness. During slide imaging, the alphanumeric slide accession identifier is recorded and the *x* and *y* coordinates of 22 fields of interest are stored in the computer database. This computer also coordinates the communication of information between the Image Processor and the Review Scopes.

After image processing, slides are distributed to Cytotechnologists for review utilizing the Review Scopes. The Review Scope is a microscope with an automated stage to facilitate the locating of the 22 fields containing the cells of interest. Additionally, the Review Scope provides a method for automated marking of objects for further review. Slides are individually loaded onto the Review Scope stage, the alphanumeric slide accession identifier is automatically scanned and the stored *x* and *y* coordinates representing fields of interest for that slide are electronically downloaded from the computer to the Review Scope. The Cytotechnologist then uses a keypad to step through each of the fields of interest (Autolocate). If the Cytotechnologist identifies any of these fields as containing abnormal objects, that field may be marked electronically. The Review Scope will guide the Cytotechnologist to conduct a review of the entire cell spot for any slide that has had fields electronically marked (Autoscan). The Cytotechnologist determines specimen adequacy and the presence of infections during the review of the 22 fields of view presented by the ThinPrep Imaging System. Either of two methods can be used to determine specimen adequacy. The first method is to count cells and determine the average number of cells in the 22 fields of view presented by the Imager. The second method is to count and determine the average number of cells in 10 fields of view across the diameter of the cell spot. Either method will enable the Cytotechnologist to determine if the minimum cells, as recommended by Bethesda System 2001 criteria, are present on the slide. At the conclusion of the slide review electronically marked objects are automatically ink marked. Any *x* and *y* coordinates representing marked locations along with a slide completion status are then electronically transmitted back to the computer for storage.

D. LIMITATIONS

- Only personnel who have been appropriately trained should operate the ThinPrep® Imaging System Image Processor or Review Scope.
- All slides that undergo primary automated screening with the Image Processor require manual rescreening of the selected fields of view by a Cytotechnologist using a Review Scope.
- The ThinPrep Imaging System is only indicated for use with the ThinPrep Pap Test.
- The laboratory Technical Supervisor should establish individual workload limits for personnel using the ThinPrep Imaging System. *The maximum daily limit specified is only an upper limit and should never be used as an expectation for daily productivity or as a performance target.*
- The ThinPrep Imaging System has not been proven to be safe or effective at workload levels which exceed product labeling.
- ThinPrep slides with fiducial marks must be used.
- Slides must be stained using the ThinPrep Stain according to the applicable ThinPrep Imaging System slide staining protocol.
- Slides should be clean and free of debris before being placed on the system.
- The slide coverslip should be dry and located correctly.
- Slides that are broken or poorly coverslipped should not be used.
- Slides used with the ThinPrep Imaging System must contain properly formatted accession number identification information as described in the operator's manual.
- Slides once successfully imaged on the Image Processor cannot be imaged again.
- The performance of the ThinPrep Imaging System using slides prepared from reprocessed sample vials has not been evaluated; therefore it is recommended that these slides be manually reviewed.

E. WARNINGS

- The Imager generates, uses, and can radiate radio frequency energy and may cause interference to radio communications.
- A Hologic authorized service representative must install the ThinPrep Imaging System.

F. PRECAUTIONS

- Caution should be used when loading and unloading glass slides on the ThinPrep Imaging System to prevent slide breakage and/or injury.
- Care should be taken to assure that slides are correctly oriented in the ThinPrep Imaging System cassettes to prevent rejection by the system.
- Partially processed slide cassettes should not be removed from the Image Processor, as data may be lost.
- The Image Processor should be placed on a flat, sturdy surface away from any vibrating machinery to assure proper operation.

G. PERFORMANCE CHARACTERISTICS

A multi-center, two-armed clinical study was performed over an eleven (11) month period at four (4) cytology laboratory sites within the United States. The objective of the study entitled “Multi-Center Trial Evaluating the Primary Screening Capability of the ThinPrep® Imaging System” was to show that routine screening of ThinPrep Pap Test slides using the ThinPrep Imaging System is equivalent to a manual review of ThinPrep slides for all categories used for cytologic diagnosis (specimen adequacy and descriptive diagnosis) as defined by the Bethesda System criteria².

The two-arm study approach allowed a comparison of the cytologic interpretation (descriptive diagnosis and specimen adequacy) from a single ThinPrep prepared slide, screened first using standard laboratory cervical cytology practices (*Manual Review*) and then after a 48 day time lag were screened with the assistance of the ThinPrep Imaging System (*Imager Review*). A subset of slides from the study were reviewed and adjudicated by a panel of three (3) independent Cytopathologists to determine a consensus diagnosis. The consensus diagnosis was used as a “gold standard” for truth to evaluate the results of the study.

G.1 LABORATORY AND PATIENT CHARACTERISTICS

Of the 10,359 subjects in the study, 9,550 met the requirements for inclusion in the descriptive diagnosis analysis. During the study, 7.1% (732/10,359) slides could not be read on the Imager and required a manual review during the *Imager Review* arm. Excessive number of air bubbles on the slides was the leading contributor. Additional factors included focus problems, slide density, slide identification read failures, slides detected out of position, multiple slides seated within a cassette slot and slides that had already been imaged. The cytology laboratories participating in the study were comprised of four centers. All sites selected had extensive experience in the processing and evaluation of gynecologic ThinPrep slides, and were trained in the use of the ThinPrep Imaging System. The study population represented diverse geographic regions and subject populations of women who would undergo cervical screening with the ThinPrep Imaging System in normal clinical use. These sites included both women being routinely screened (screening population) and patients with a recent previous cervical abnormality (referral population). The characteristics of the study sites are summarized in *Table 1*.

Table 1: Site Characteristics

Site	1	2	3	4
Low Risk Population	88%	82%	90%	94%
High Risk Population	12%	18%	10%	6%
HSIL+ prevalence	1.1%	0.7%	0.4%	0.6%
ThinPrep Pap Tests Per Year	120,000	70,200	280,000	105,000
Number of Cytotechnologists	14	9	32	11
Number of Cytotechnologists in Study	2	2	2	2
Number of Cytopathologists	6	5	6	14
Number of Cytopathologists in Study	1	2	1	2

G.2 DESCRIPTIVE DIAGNOSIS SENSITIVITY AND SPECIFICITY ESTIMATES

A panel of three independent Cytopathologists adjudicated slides from all discordant (one-grade or higher cytologic difference) descriptive diagnosis cases (639), all concordant positive cases (355) and a random 5% subset of the 8550 negative concordant cases (428). The Cytopathologists on the adjudication panel were board-certified, all of whom had a subspecialty certification in Cytopathology. Their experience levels in Cytopathology ranged from 6 to 12 years. Two of the adjudicators were from university practices and one adjudicator was from a private medical center. The volumes for the adjudicator’s institutions ranged from 12,000 to 30,000 ThinPrep® Pap Tests annually.

A consensus diagnosis was defined as agreement by at least 2 of 3 Cytopathologists. All slides sent to the panel of Cytopathologists were not identified by site nor ordered in any fashion. When a consensus diagnosis could not be obtained by at least 2 of 3 Cytopathologists, the full panel of Cytopathologists reviewed each case simultaneously using a multi-headed microscope to determine a consensus diagnosis.

The adjudicated results were used as a “gold standard” to define the following major “true” descriptive diagnosis classifications of the Bethesda System: Negative, ASCUS, AGUS, LSIL, HSIL, Squamous Cell Carcinoma (SQ CA) and Glandular Cell Carcinoma (GL CA). Estimates of sensitivity and specificity together with 95% confidence intervals were calculated for the *Manual Review* and *Imager Review* arms of the study. The differences in sensitivity and specificity between the two arms, together with their 95% confidence intervals were also calculated. Among the random 5% subset of 8,550 cases (428 slides) that were found to be negative by both arms and adjudicated, there were 425 “true” negative and 3 “true” ASCUS slides. A multiple imputation technique was used to adjust the numbers of true positives and true negatives for the 8,550 negative concordant cases based on the 5% of cases that were adjudicated³.

Tables 2-4 below summarize the descriptive diagnosis sensitivity and specificity estimates with 95% confidence intervals for each of the four sites and all sites combined for “true” ASCUS+, LSIL+ and HSIL+.

Table 2: Adjudicated Review Versus Imager And Manual Reviews ASCUS+ Descriptive Diagnosis Summary.

Sensitivity is a percent of “true” ASCUS+ (combined ASCUS, AGUS, LSIL, HSIL, SQ CA and GL CA) slides classified in either study arm as ASCUS+ and specificity is a percent of “true” Negative slides classified in either study arm as Negative.

Sensitivity				Specificity			
Site/ Number Cases	Manual	Imager	Difference	Site/ Number Cases	Manual	Imager	Difference
Site 1 180	77.2% (70.4, 83.1)	78.3% (71.6, 84.1)	+1.1% (-5.8, 8.0)	Site 1 2132	98.7% (98.1, 99.1)	99.2% (98.7, 99.5)	+0.4% (-0.1, 1.0)
Site 2 230	63.1% (56.5, 69.3)	77.5% (71.4, 82.6)	+14.4% (8.2, 20.5)	Site 2 2210	95.8% (94.9, 96.6)	96.1% (95.2, 96.9)	+0.3% (-0.7, 1.3)
Site 3 103	80.6% (71.6, 87.7)	94.2% (87.8, 97.8)	+13.6% (4.3, 22.9)	Site 3 2196	98.5% (97.9, 99.0)	98.8% (98.3, 99.2)	+0.4% (-0.3, 1.0)
Site 4 179	87.2% (81.4, 91.7)	84.4% (78.2, 89.4)	-2.8% (-10.6, 5.0)	Site 4 2313	97.3% (96.6, 97.9)	97.0% (96.2, 97.7)	-0.3% (-1.1, 0.5)
All 692	75.6% (72.2, 78.8)	82.0% (78.8, 84.8)	+6.4% (2.6, 10.0)	All 8851	97.6% (97.2, 97.9)	97.8% (97.4, 98.1)	+0.2% (-0.2, 0.6)

Numbers in parentheses represent 95% confidence intervals.

The results presented in Table 2 show that for ASCUS+, the increase in sensitivity of the *Imager Review* over the *Manual Review* was statistically significant with the lower limit of the 95% confidence interval being 2.6% for all sites combined. The observed difference between sensitivities for ASCUS+ varied among the sites from -2.8% with a 95% confidence interval of (-10.6%; 5.0%) to +14.4% with a 95% confidence interval of (8.2%; 20.5%). The difference in specificity results between the *Imager Review* and the *Manual Review* was not statistically significant with a 95% confidence interval of -0.2% to +0.6%. The observed differences between specificities varied among the sites from -0.3% to +0.4%.

Table 3: Adjudicated Review Versus Imager Review LSIL+ Descriptive Diagnosis Summary for Each Site and All Sites Combined.

Sensitivity is a percent of “true” LSIL+ (combined LSIL, HSIL, SQ CA and GL CA) slides classified in either study arm as LSIL+ and specificity is a percent of “true” Non-LSIL+ (combined Negative, ASCUS, AGUS) slides classified in either study arm as Non-LSIL+.

Sensitivity				Specificity			
Site/ Number Cases	Manual	Imager	Difference	Site/ Number Cases	Manual	Imager	Difference
Site 1 104	84.6% (76.2, 90.9)	82.7% (74.0, 89.4)	-1.9% (-9.5, 5.6)	Site 1 2208	98.7% (98.1, 99.1)	99.3% (98.9, 99.6)	+0.6% (0.1, 1.0)
Site 2 98	70.4% (60.3, 79.2)	72.4% (62.5, 81.0)	+2.0% (-6.9, 11.0)	Site 2 2342	99.3% (98.8, 99.6)	98.9% (98.4, 99.3)	-0.4% (-0.8, .001)
Site 3 62	77.4% (65.0, 87.1)	85.5% (74.2, 93.1)	+8.1% (-4.0, 20.1)	Site 3 2237	99.2% (98.7, 99.5)	99.5% (99.1, 99.8)	+0.3% (-0.1, 0.6)
Site 4 111	84.7% (98.1, 99.1)	78.4% (76.6, 90.8)	-6.3% (-14.7, 2.1)	Site 4 2381	98.7% (98.2, .99.2)	98.7% (98.1, 99.1)	-0.08% (-0.6, 0.4)
All 375	79.7% (75.3, 83.7)	79.2% (74.7, 83.2)	-0.5% (-5.0, 4.0)	All 9168	99.0% (98.8, 99.2)	99.1% (98.9, 99.3)	+0.09% (-0.1, 0.3)

Numbers in parentheses represent 95% confidence intervals.

The results presented in *Table 3* show that the difference between sensitivities of the *Imager Review* and *Manual Review* arms for LSIL+ for all sites combined was not statistically significant with a 95% confidence interval of -5.0% to +4.0%. The observed difference between sensitivities for LSIL+ varied among the sites from -6.3% with a 95% confidence interval of (-14.7%; 2.1%) to +8.1% with a 95% confidence interval of (-4.0%; 20.1%). The difference in specificity results between the *Imager Review* and the *Manual Review* was not statistically significant with a 95% confidence interval of -0.1% to +0.3%. The observed differences between specificities varied among the sites from -0.4% to +0.6%.

Table 4: Adjudicated Review Versus Imager Review HSIL+ Descriptive Diagnosis Summary for Each Site and All Sites Combined.

Sensitivity is a percent of “true” HSIL+ (combined HSIL, SQ CA and GL CA) slides classified in either study arm as HSIL+ and specificity is a percent of “true” Non-HSIL+ (combined Negative, ASCUS, AGUS, LSIL) slides classified in either study arm as Non-HSIL+.

Sensitivity				Specificity			
Site/ Number Cases	Manual	Imager	Difference	Site/ Number Cases	Manual	Imager	Difference
Site 1 38	89.5% (75.2, 97.1)	92.1% (78.6, 98.3)	2.6% (-8.9, 14.1)	Site 1 2274	98.8% (98.3, 99.2)	99.5% (99.1, 99.8)	+0.7% (0.2, 1.2)
Site 2 40	72.5% (56.1, 85.4)	70.0% (53.4, 83.4)	-2.5% (-15.4, 10.4)	Site 2 2400	99.8% (99.5, 99.9)	99.6% (99.2, 99.8)	-0.1% (-0.3, .09)
Site 3 22	72.7% (49.8, 89.3)	86.4% (65.1, 97.1)	+13.6% (-0.7, 28.0)	Site 3 2277	99.7% (99.4, 99.9)	99.7% (99.4, 99.9)	0% (-0.2, 0.2)
Site 4 39	61.5% (44.6, 76.6)	74.4% (57.9, 87.0)	+12.8% (-1.7, 27.4)	Site 4 2453	99.5% (99.2, 99.8)	99.8% (99.5, 99.9)	+0.3% (-0.003, 0.6)
All 139	74.1% (66.0, 81.2)	79.9% (72.2, 86.2)	+5.8% (-1.1, 12.6)	All 9404	99.4% (99.2, 99.6)	99.6% (99.5, 99.7)	+0.2% (0.06, 0.4)

Numbers in parentheses represent 95% confidence intervals.

The results presented in *Table 4* show that the difference between sensitivities of the *Imager Review* and *Manual Review* arms for HSIL+ for all sites combined was not statistically significant with a 95% confidence interval of -1.1% to +12.6%. The observed difference between sensitivities for HSIL+ varied among the sites from -2.5% with a 95% confidence interval of (-15.4%; 10.4%) to +13.6% with a 95% confidence interval of (-0.7%; 28.0%). The increase in specificity of the *Imager Review* over the *Manual Review* was statistically significant with a 95% confidence interval of +0.06% to +0.4%. The observed differences between specificities varied among the sites from -0.1% to +0.7%.

Tables 5-9 show the performance of the *Imager Review* and *Manual Review* compared to the final consensus diagnosis made by the adjudication panel (truth) for the following major descriptive diagnosis classifications of the Bethesda System: Negative, ASCUS, AGUS, LSIL, HSIL, Cancer* (CA)

*Includes SQ CA and GL CA.

Abbreviations for Diagnoses: *NEG* = Normal or negative, *ASCUS* = Atypical Squamous Cells of Undetermined Significance, *AGUS* = Atypical Glandular Cells of Undetermined Significance, *LSIL* = Low-grade Squamous Intraepithelial Lesion, *HSIL* = High-grade Squamous Intraepithelial Lesion, *SQ CA* = Squamous Cell Carcinoma, *GL CA* = Glandular Cell Adenocarcinoma.

Table 5: 6x6 “True Negative” Contingency Table For All Sites Combined

All 786 Cases Determined To Be Negative By Adjudication

		Unadjudicated Manual Review Arm Diagnosis						TOTAL
		NEG	ASCUS	AGUS	LSIL	HSIL	CA	
Unadjudicated Imager Review Arm Diagnosis	NEG	425	138	6	10	6	2	587
	ASCUS	130	39	1	3	-	-	173
	AGUS	5	-	-	-	-	-	5
	LSIL	9	5	-	2	-	-	16
	HSIL	1	1	-	-	3	-	5
	CA	-	-	-	-	-	-	0
	TOTAL	570	183	7	15	9	2	786

Among the 786 cases determined by the adjudication panel to be Negative, 587 (74.7%) cases in the *Imager Review* arm and 570 (72.5%) cases in the *Manual Review* arm were diagnosed as Negative and 21 (2.7%) cases in the *Imager Review* arm and 26 (3.3%) cases in the *Manual Review* arm were diagnosed as LSIL+.

Table 6: 6x6 “True ASCUS” Contingency Table For All Sites Combined

All 251 Cases Determined To Be ASCUS By Adjudication

		Unadjudicated Manual Review Arm Diagnosis						TOTAL
		NEG	ASCUS	AGUS	LSIL	HSIL	CA	
Unadjudicated Imager Review Arm Diagnosis	NEG	3	32	-	7	3	-	45
	ASCUS	70	47	1	20	4	-	142
	AGUS	1	-	-	-	-	-	1
	LSIL	6	21	-	16	7	-	50
	HSIL	2	3	-	5	1	1	12
	CA	1	-	-	-	-	-	1
	TOTAL	83	103	1	48	15	1	251

Among the 251 cases determined by the adjudication panel to be ASCUS, 142 (56.6%) cases in the *Imager Review* arm and 103 (41.0%) cases in the *Manual Review* arm were diagnosed as ASCUS and 45 (17.9%) cases in the *Imager Review* arm and 83 (33.1%) cases in the *Manual Review* arm were diagnosed as Negative.

Table 7: 6x6 “True AGUS” Contingency Table For All Sites Combined

All 10 Cases Determined To Be AGUS By Adjudication

		Unadjudicated Manual Review Arm Diagnosis						
		NEG	ASCUS	AGUS	LSIL	HSIL	CA	TOTAL
Unadjudicated Imager Review Arm Diagnosis	NEG	-	2	1	-	1	-	4
	ASCUS	-	-	1	-	-	-	1
	AGUS	2	-	1	-	-	1	4
	LSIL	-	-	-	-	-	-	0
	HSIL	-	-	-	-	-	-	0
	CA	-	-	-	-	-	1	1
	TOTAL	2	2	3	0	1	2	10

Among the 10 cases determined by the adjudication panel to be AGUS, 4 (40.0%) cases in the *Imager Review* arm and 3 (30.0%) cases in the *Manual Review* arm were diagnosed as AGUS and 4 (40.0%) cases in the *Imager Review* arm and 2 (20.0%) cases in the *Manual Review* arm were diagnosed as Negative.

Table 8: 6x6 “True LSIL” Contingency Table For All Sites Combined

All 236 Cases Determined To Be LSIL By Adjudication

		Unadjudicated Manual Review Arm Diagnosis						
		NEG	ASCUS	AGUS	LSIL	HSIL	CA	TOTAL
Unadjudicated Imager Review Arm Diagnosis	NEG	-	4	-	12	1	-	17
	ASCUS	13	16	-	20	1	-	50
	AGUS	-	-	-	-	-	-	0
	LSIL	8	20	-	115	12	-	155
	HSIL	-	-	-	5	9	-	14
	CA	-	-	-	-	-	-	0
	TOTAL	21	40	0	152	23	0	236

Among the 236 cases determined by the adjudication panel to be LSIL, 155 (65.6%) cases in the *Imager Review* arm and 152 (64.4%) cases in the *Manual Review* arm were diagnosed as LSIL and 17 (7.2%) cases in the *Imager Review* arm and 21 (8.9%) cases in the *Manual Review* arm were diagnosed as Negative.

Table 9: 6x6 “True HSIL” Contingency Table For All Sites Combined

All 138 Cases Determined To Be HSIL By Adjudication

		Unadjudicated Manual Review Arm Diagnosis						
		NEG	ASCUS	AGUS	LSIL	HSIL	CA	TOTAL
Unadjudicated Imager Review Arm Diagnosis	NEG	-	1	-	-	1	-	2
	ASCUS	2	4	-	2	1	-	9
	AGUS	-	-	-	-	-	-	0
	LSIL	1	-	-	10	6	-	17
	HSIL	3	3	1	9	91	1	108
	CA	-	-	-	-	1	1	2
	TOTAL	6	8	1	21	100	2	138

Among the 138 cases determined by the adjudication panel to be HSIL, 108 (78.3%) cases in the *Imager Review* arm and 100 (72.5%) cases in the *Manual Review* arm were diagnosed as HSIL and 2 (1.4%) cases in the *Imager Review* arm and 6 (4.3%) cases in the *Manual Review* arm were diagnosed as Negative.

There was one (1) squamous cell carcinoma (SQ CA) case resulting from adjudication. It was diagnosed as HSIL in the *Imager Review* arm and SQ CA in the *Manual Review* arm.

Table 10 shows the study subjects unadjudicated descriptive diagnosis marginal frequencies for benign cellular changes for all sites combined.

Table 10: Unadjudicated Marginal Frequencies Summary of Descriptive Diagnosis for Benign Cellular Changes – All Sites Combined.

	Manual Review		Imager Review	
Number of Patients:	9550		9550	
Descriptive Diagnosis	N	%	N	%
Benign Cellular Changes:	405	4.2	293	3.1
Infection:				
Trichomonas Vaginalis	8	0.1	8	0.1
Fungal organisms consistent with Candida spp.	47	0.5	31	0.3
Predominance of coccobacilli	71	0.7	60	0.6
Bacteria consistent with Actinomyces spp.	1	0.0	1	0.0
Cellular Changes associated with Herpes virus	1	0.0	1	0.0
Other Infection	1	0.0	0	0.0
Reactive Cellular Changes Associated with:				
Inflammation	218	2.3	156	1.6
Atrophic with inflammation (atrophic vaginitis)	68	0.7	46	0.5
Radiation	0	0.0	0	0.0
Intrauterine contraceptive device (IUD)	0	0.0	0	0.0
Other Reactive Cellular Change	34	0.4	14	0.1

Note: Some patients had more than one diagnostic subcategory.

The *Manual Review* showed a higher rate of Benign Cellular Changes (405) than the *Imager Review* cases (293).

G.3 ANALYTICAL PERFORMANCE OF THINPREP IMAGING SYSTEM FOR DETECTION OF CERVICAL CANCER USING THINPREP® PAP TEST SLIDES FRESHLY PREPARED FROM ARCHIVAL SAMPLES

This analytical study was conducted to compare the Bethesda System 2001 results, obtained by a Cytotechnologist and a Cytopathologist, when their review was limited to 22 fields that were selected by the ThinPrep Imaging System, to their diagnostic results obtained from their independent blinded review of the entire cell spot on the ThinPrep Pap Test slides. All of the reviews were performed in an independent and blinded manner. The test materials consisted of 33 archival PreservCyt-preserved cervical samples that had been previously diagnosed as AGUS or cancer. One ThinPrep Pap Test slide was freshly prepared from each of the 33 original PreservCyt vials. All of the ThinPrep slides used in the study were made on the TP-2000 processor and stained with ThinPrep Stain. Based on the current cervical cancer prevalence rate in the United States, 33 cases of cervical cancer would represent the number of invasive cervical cancer cases in a population of approximately 275,000 women⁴.

Initially, a board-certified Cytopathologist manually reviewed all of the fields on the ThinPrep Pap Test slides and identified and recorded the number of individual cancer cells and clusters of cancer cells that were present. For this part of the study, the Cytopathologist was not required to record any other cells with other Bethesda System 2001 diagnoses. The 33 cases included slides that represented both rare numbers of cancer cells (5-20 per slide), and numerous cancer cells (>20/slide). Cancer cells were categorized according to Bethesda System 2001 criteria for Glandular Cancer, Adenocarcinoma-in-situ and Squamous Cell Cancer. Each slide was then processed on a ThinPrep Imaging System. The Cytotechnologist then reviewed *only* the 22 fields of view presented by the Autolocate mode of the Review Scope. No review outside of the selected 22 fields of view was permitted. For each field of view, the Cytotechnologist counted and recorded all abnormal cell types based on the following seven Bethesda System classifications: ASCUS, LSIL, HSIL, AGUS, Glandular Cancer, Squamous Cell Carcinoma and Adenocarcinoma-In-Situ.

Finally, the same Cytopathologist who had conducted the manual review of the entire ThinPrep® Pap Test slide, independently re-reviewed the slides using the identical method used by the Cytotechnologists. The Cytopathologist was blinded from the original manual review results. For each of the 22 fields of view selected by the ThinPrep Imaging System, the Cytopathologist verified and recorded the number of individual cancer cells, clusters of cancer cells, and any other abnormalities present. *Table 11* summarizes the results from this study:

Table 11: Summary of Results From Restricted Analytical Cancer Study

Cytopathologist Full Manual Review	Cytotechnologist Review of Imager Identified 22 Fields of View *	Cytopathologist Review of Imager Identified 22 Fields of View **
10 Glandular Cancer	5 Glandular Carcinoma 1 Squamous Cell Carcinoma 1 Adenocarcinoma In-situ 2 HSIL/AGUS 1 ASC-H/ASC-US	7 Glandular Carcinoma 1 Squamous Cell Carcinoma 1 AGUS 1 HSIL
1 Adenocarcinoma In-situ	1 Adenocarcinoma In-Situ	1 Adenocarcinoma In-Situ
22 Squamous Cell Carcinoma	3 Glandular Carcinoma 12 Squamous Cell Carcinoma 1 Squamous/Glandular Carcinoma 2 Adenocarcinoma In-situ 4 HSIL	21 Squamous Cell Carcinoma 1 Adenocarcinoma In-situ
Total = 33	Total = 33	Total = 33

* In the intended use of the ThinPrep Imaging System (Imager), the Cytotechnologist would perform a full manual slide review of each of these cases and pass them on to a Cytopathologist for further review.

**In the intended use of the ThinPrep Imaging System (Imager), the Cytopathologist would perform a full manual slide review of each of these cases.

The results in *Table 11* demonstrate the ability of the ThinPrep Imaging System to successfully identify abnormalities in the 22 fields of view presented during the Autolocate mode of slide review. In all 33 cases in this study, the ThinPrep Imaging System identified and presented cells among the 22 fields of view that were categorized as Cancer, HSIL, AGUS or ASCUS. In addition, the Cytopathologists' confirming review of the identical 22 fields of view showed consistent, but slightly improved results with all cases being categorized as Cancer, HSIL or AGUS. Consistent with the intended use of the ThinPrep Imaging System, the Cytotechnologists' diagnoses in every one of these 33 cases would have invoked the full slide Autoscan mode that would require a Cytotechnologist to screen the entire slide before making a final diagnosis. The results of this study indicate that ThinPrep Imaging System will accurately lead to a full manual slide review for the detection of cervical cancer or its precursor lesions.

G.4 SPECIMEN ADEQUACY STUDY

Of the 10,359 subjects in the study, 9627 met the requirements for inclusion in the specimen adequacy analysis.

Table 12: Unadjudicated Marginal Frequencies Summary of Specimen Adequacy Results – All Sites Combined.

Number of Patients: Descriptive Diagnosis	Manual Review		Imager Review	
	9627		9627	
	N	%	N	%
Satisfactory for Evaluation	7375	76.6	7346	76.3
Satisfactory but Limited by	2186	22.7	2252	23.4
Endocervical Component Absent	1196	12.4	1397	14.5
Scant Squamous Epithelial Component	92	1.0	102	1.1
Obscuring Blood	45	0.5	17	0.2
Obscuring Inflammation	69	0.7	68	0.7
No Clinical History	982	10.2	933	9.7
Cytolysis	4	0.0	2	0.0
Other	6	0.1	33	0.3
Unsatisfactory for Evaluation	66	0.7	29	0.3
Endocervical Component Absent	6	0.1	0	0.0
Scant Squamous Epithelial Component	35	0.4	22	0.2
Obscuring Blood	17	0.2	2	0.0
Obscuring Inflammation	8	0.1	5	0.1
No Clinical History	2	0.0	2	0.0
Cytolysis	0	0.0	0	0.0
Other	2	0.0	0	0.0

Note: Some patients had more than one diagnostic subcategory.

For SAT cases, there was agreement between the *Manual Review* cases (7375) and the *Imager Review* cases (7346). For SBLB cases, there is agreement between the *Manual Review* cases (2186) and the *Imager Review* cases (2252). Unsatisfactory cases were greater in the *Manual Review* cases (66) versus the *Imager Review* cases (29).

The adjudicated results were used as a “gold standard” to define “true” specimen adequacy classifications of the Bethesda System: SAT/SBLB and UNSAT. There were 58 “true” UNSAT cases and 9569 “true” SAT/SBLB cases.

Table 13 below summarizes specimen adequacy performance for the Imager Review and Manual Review arms for all four sites and all sites combined using the Bethesda System 1991 criteria.

Table 13: Adjudicated Review Versus Imager Review Specimen Adequacy Summary for All Sites and All Sites Combined.

Sensitivity is a percent of “true” UNSAT slides classified in either study arm as UNSAT and specificity is a percent of “true” SAT/SBLB slides classified in either study arm as SAT/SBLB.

Sensitivity				Specificity			
Site/ Number Cases	Manual	Imager	Difference	Site/ Number Cases	Manual	Imager	Difference
Site 1 21	0% (0/21)	0% (0/21)	0.0% (0/21)	Site 1 2292	100% (2292/2292)	100% (2292/2292)	0.0% (0/2292)
Site 2 6	100% (6/6)	16.7% (1/6)	-83.3% (-5/6)	Site 2 2476	98.9% (2449/2476)	99.6% (2465/2476)	+0.6% (16/2476)
Site 3 5	80.0% (4/5)	60.0% (3/5)	-20.0% (-1/5)	Site 3 2323	99.2% (2304/2323)	99.7% (2315/2323)	+0.5% (11/2323)
Site 4 26	30.8% (8/26)	19.2% (5/26)	-11.5% (-3/26)	Site 4 2478	99.9% (2475/2478)	99.9% (2476/2478)	+0.04% (1/2478)
All 58 CI*	29.3% (17/58) (18.1, 42.7)	13.8% (8/58) (6.1, 25.4)	-15.5% (-9/58) (-25.9, -5.0)	All 9569 CI*	99.5% (9520/9569) (99.3, 99.6)	99.8% (9548/9569) (99.7, 99.9)	+0.3% (28/9569) (0.2, 0.4)

*95% Confidence Interval

All ThinPrep® slides that produced discordant unsatisfactory determinations (*Manual Review* arm

vs. *Imager Review* arm) during the clinical study were assessed in an additional clinical support study to compare the method used for specimen adequacy in the clinical study with a control cell count of the slides and 3 different methods as follows: (1) Manual assessment of specimen adequacy on the entire microscope slide based on ThinPrep Bethesda System 1991 criteria; (2) Using the “diameter” method of Bethesda System 2001, which requires that the Cytotechnologist counts cells in 10 fields of view along the diameter of the cell spot and calculate the number of cells on the slide; (3) Having the Cytotechnologist count the cells in the 22 fields of view presented by the system and calculate the number of cells on the slide.

This additional support study demonstrated that the Bethesda System 1991 estimation methods, including the method used in the clinical study, do not generate similar specimen adequacy determinations when compared against each other or with the control method. Therefore, the recommended methods for determining specimen adequacy on the ThinPrep Imaging System are (1) the Bethesda System 2001 count of fields along a diagonal of the cell spot or (2) counting the cells in the 22 fields-of-view selected by the ThinPrep Imager System. Refer to the ThinPrep Imaging System Review Scope Operator’s Manual for instructions on the proper use of these methods.

G.5 CYTOTECHNOLOGIST SCREENING RATES

Daily Cytotechnologist screening rates were recorded throughout the duration of the clinical study. The study was conducted in a manner designed to reproduce actual clinical conditions. Eight (8) Cytotechnologists participated in the study; two (2) at each clinical site. The experience levels of the Cytotechnologists ranged from 5 to 23 years. During the study the Cytotechnologist’s screening times for the *Imager Review* arm included automated screening of the 22 fields of view with subsequent full side review of abnormal slides. A full slide review consists of approximately 120 fields of view. The number of hours each Cytotechnologist screened slides per day varied due to logistical issues and scheduling. With the ThinPrep Imaging System, Cytotechnologist screening rates were uniformly faster than the *Manual Review* method.

Table 14 summarizes the Cytotechnologist screening rates for both the *Imager Review* and the *Manual Review* methods. The total number of slides reviewed in the study and the average number of hours screened per day are presented for each Cytotechnologist and site. Screening rates (extrapolated to an 8 hour workday) are presented as the low, average and high daily screening rates achieved by each Cytotechnologist and site. The low and high daily rates were selected from the lowest and highest daily hourly rates, respectively, and are extrapolated to 8 hours.

Table 14: Cytotechnologist Screening Rates

Site/CT	Review Methods	Total Number of Slides Evaluated	Average Number of Hours Screened Per Day	Extrapolated Daily Rates (8-hour workday)		
				Low Day	Average Day	High Day
Site 1	Manual	2568	7.4	49	69	94
	Imager	2297	6.0	107	153	206
1-1	Manual	1284	7.5	49	60	72
	Imager	1168	6.1	117	153	182
1-2	Manual	1284	7.3	70	78	94
	Imager	1129	5.9	107	154	206
Site 2	Manual	2686	7.7	40	68	80
	Imager	2665	7.8	69	109	131
2-1	Manual	1348	7.6	40	71	80
	Imager	1309	7.9	97	110	118
2-2	Manual	1338	7.8	55	66	75
	Imager	1356	7.7	69	109	131
Site 3	Manual	2738	7.9	20	80	101
	Imager	2726	4.5	148	204	320
3-1	Manual	1368	7.9	63	82	91
	Imager	1460	4.2	167	230	320
3-2	Manual	1370	7.8	20	78	101
	Imager	1266	4.7	148	178	212
Site 4	Manual	2612	7.6	42	69	94
	Imager	2524	5.1	86	138	198
4-1	Manual	1305	8.2	59	75	84
	Imager	1252	5.1	86	150	190
4-2	Manual	1307	6.9	42	63	94
	Imager	1272	5.0	109	126	198

Table 15 summarizes the Manual Review versus the Imager Review for ASCUS+ and HSIL+ sensitivity and specificity by site. The table also presents the prevalence of ASCUS+, LSIL+, and HSIL+ among the reviewed slides and the respective screening daily rates of each review method. The daily screening rates are extrapolated to an 8-hour workday and are presented as the low, average and high daily screening rates by site.

Table 15: Screening Rates, Prevalence of ASCUS+, LSIL+, HSIL+, and Respective Performance for ASCUS+ and HSIL+.

Site	% of ASCUS+	% of LSIL+	% of HSIL+	Review Methods	Extrapolated Daily Rates (8-hour workday)			Performance for ASCUS+			Performance for HSIL+				
					Low Day	Average Day	High Day	Sensitivity	Specificity	Sensitivity	Specificity				
Site 1	7.7%	4.5%	1.6%	Manual	49	69	94	77.2%		98.7%		89.5%		98.8%	
				Imager	107	153	206	78.3%	+1.1%	99.2%	+0.4%	92.1%	+2.6%	99.5%	+0.7%
Site2	9.2%	4.0%	1.6%	Manual	40	68	80	63.1%		95.8%		72.5%		99.8%	
				Imager	69	109	131	77.7%	+14.4%	96.1%	+0.3%	70.0%	-2.5%	99.6%	-0.1%
Site 3	4.4%	2.7%	1.0%	Manual	20	80	101	80.6%		98.5%		64.3%		99.7%	
				Imager	148	204	320	94.2%	+13.6%	98.8%	+0.4%	78.6%	+13.6%	99.7%	0%
Site 4	7.2%	4.5%	1.6%	Manual	42	69	94	87.2%		97.3%		61.5%		99.5%	
				Imager	86	138	198	84.4%	-2.8%	97.0%	-0.3%	74.4%	+12.8%	99.8%	+0.3%

The clinical study data show that the screening rates achieved with the ThinPrep® Imaging System resulted in sensitivity or specificity values that fall within acceptable limits.

Laboratorians should use the following method when calculating workload:

- All slides with Fields of View (FOV) only review count as 0.5 or ½ slide
- All slides with full manual review (FMR) using the Autoscan feature count as 1 slide (as mandated by CLIA '88 for manual screening)
- Then, slides with **both** FOV and FMR count as 1.5 or 1½ slides
- Use these values to count workload, not exceeding the CLIA maximum limit of 100 slides in no less than an 8-hour day.

<p style="text-align: center;">FMR = 1 slide FOV = 0.5 slide FMR + FOV = 1.5 slides Upper Limit = 100 slides</p>
--

The ThinPrep® Imaging System limit of 100 slides in an 8-hour workday includes the following:

- Screening 22 Fields of View
- Full manual slide review using the Autoscan feature
- Review clinical history
- Record results and triage appropriately

An example of workload scenario for ThinPrep Pap slides using the ThinPrep Imaging System:

100 FOV review only = 50 slides (100 x 0.5 = 50)

30 FOV review + FMR = 45 slides (30 x 1.5 = 45)

Total number of slides screened = 95 (50 FOV only and 45 FOV + FMR)

- **Note:** ALL laboratories should have a clear standard operation procedure for documentation of their method of workload counting and for establishing workload limits.
- It is the responsibility of the Technical Supervisor to evaluate and set workload limits for individual cytotechnologists based on laboratory clinical performance.

According to CLIA '88, these workload limits should be reassessed every six months.

For less than an 8-hour workday, the following formula must be applied to determine the maximum number of slides to be reviewed during that workday:

$$\left(\frac{\text{Number of hours examining slides}}{8} \right) \times 100$$

The manual workload limit does not supercede the CLIA requirement of 100 slides in a 24-hour period in no less than an 8-hour day. Manual review includes the following types of slides:

- Slides reviewed on the ThinPrep Imaging System using the Autoscan feature
- Slides reviewed without the ThinPrep Imaging System
- Non-gynecologic slides.

When conducting manual review, refer to the CLIA requirements for calculating workload limits.

G.6 THINPREP IMAGING SYSTEM USE WITH THINPREP 5000 PROCESSOR

A study was conducted to estimate the Positive Percent Agreement (PPA) and Negative Percent Agreement (NPA) for Imager-assisted review as compared with manual review of specimens processed on the ThinPrep 5000 processor.

Clinical Study Design

The study was a prospective, multi-center, blinded evaluation of ThinPrep slides of known diagnoses generated from residual cytological specimens which were prepared, reviewed and adjudicated in a previous study.

One thousand two hundred sixty (1260) slides were prepared on a ThinPrep 5000 processor and were reviewed independently by a Cytotechnologist and confirmed by a Pathologist. All cytologic diagnoses were determined in accordance with the Bethesda System 2001 criteria for all slides¹. The study was conducted at Hologic, Inc., Marlborough, MA and at two external laboratories in the United States.

Table 16: Laboratory Imager-Assisted Review Diagnosis vs. Laboratory Manual Review Diagnosis by one Pair of Cytotechnologist/Pathologist (Combined Sites)

Lab Imager-Assisted Review Diagnosis	Lab Manual Review Diagnosis								
	UNSAT	NILM	ASC-US	AGUS	LSIL	ASC-H	HSIL	Cancer	Total
UNSAT	30	10	2	0	1	0	0	0	43
NILM	10	620	36	1	5	5	3	1	681
ASC-US	3	40	35	10	8	1	2	0	99
AGUS	0	10	28	127	8	0	8	0	181
LSIL	0	4	9	4	14	2	13	0	46
ASC-H	2	2	1	0	1	3	1	2	12
HSIL	1	3	6	15	24	2	111	5	167
Cancer	1	0	0	0	1	1	7	21	31
Total	47	689	117	157	62	14	145	29	1260

Reference Diagnosis by Adjudication Review

All slides were subject to an adjudication review. Adjudication was done at a facility that was not one of the study sites conducting the study. Slides for adjudication were evenly divided between three (3) adjudication panels each consisting of one (1) Cytotechnologist and three (3) independent Pathologists. Each adjudication panel was blinded to the original review diagnosis for all slides and each independent Pathologist within each panel was also blinded to other adjudicator’s diagnoses for all slides. Adjudication consensus agreement was obtained for each slide reviewed. Consensus agreement was achieved when at least two (2) of the three (3) Pathologists from a panel rendered an identical diagnosis. In cases where consensus agreement was not achieved the panel members were brought together at a multi-head microscope to review the slides together and come to a consensus diagnosis.

In the study, there were 18 Cancer, 92 HSIL, 37 ASC-H, 180 LSIL, 18 AGUS, 122 ASC-US, 770 NILM, and 23 UNSAT specimens. Clinical sensitivity and specificity (e.g., with reference to a histological diagnosis) cannot be measured in this study which relied on cytological examination alone. Instead, laboratory positive and negative diagnoses by both methods, Imager-assisted and manual review, for the specimens with Reference Diagnosis of ASC-US+ (combined ASC-US, AGUS, LSIL, ASC-H, HSIL, and Cancer), LSIL+ (combined LSIL, ASC-H, HSIL, and Cancer), ASC-H+ (combined ASC-H, HSIL, and Cancer) and HSIL+ (combined HSIL and Cancer) were compared.

Clinical Study Results

Tables 17 through 20 present the comparison of Laboratory true positive and negative rates for ASC-US+, LSIL+, ASC-H+, and HSIL+.

Table 17: Laboratory Imager-Assisted Review Results vs. Laboratory Manual Review Results for the Specimens with Reference Diagnosis of ASC-US+

In the study, there were 467 specimens with Reference Diagnosis of ASC-US+ (combined ASC-US, AGUS, LSIL, ASC-H, HSIL, and Cancer) and 770 specimens with Reference Diagnosis of NILM.

In this table, "Positive" means ASC-US+ or UNSAT, and "Negative" means NILM. All percentages are rounded to the nearest 0.1%.

ASC-US+	Positive Percent Agreement			Negative Percent Agreement		
Lab CT/ Pathologist	Imager-Assisted (95% CI)	Manual (95% CI)	Difference (95% CI)	Imager-Assisted (95% CI)	Manual (95% CI)	Difference (95% CI)
#1	93.8% (287/306) (90.5% to 96.0%)	95.1% (291/306) (92.1% to 97.0%)	-1.3% (-4/306) (-4.2% to 1.5%)	84.4% (434/514) (81.0% to 87.3%)	81.9% (421/514) (78.3% to 85.0%)	2.5% (13/514) (-0.2% to 5.3%)
#2	91.6% (428/467) (88.8% to 93.8%)	92.3% (431/467) (89.5% to 94.4%)	-0.6% (-3/467) (-3.3% to 1.9%)	84.8% (653/770) (82.1% to 87.2%)	85.2% (656/770) (82.5% to 87.5%)	-0.4% (-3/770) (-2.9% to 2.1%)
#3	91.9% (429/467) (89.0% to 94.0%)	91.4% (427/467) (88.5% to 93.6%)	0.4% (2/467) (-2.1% to 3.0%)	83.0% (639/770) (80.2% to 85.5%)	83.4% (642/770) (80.6% to 85.8%)	-0.4% (-3/770) (-2.9% to 2.1%)
Combined	92.3% (1144/1240) (90.6% to 93.6%)	92.7% (1149/1240) (91.1% to 94.0%)	-0.4% (-5/1240) (-1.9% to 1.1%)	84.0% (1726/2054) (82.4% to 85.6%)	83.7% (1719/2054) (82.0% to 85.2%)	0.3% (7/2054) (-1.1% to 1.8%)

Table 18: Laboratory Imager-Assisted Review Results vs. Laboratory Manual Review Results for the Specimens with Reference Diagnosis of LSIL+

In the study, there were 327 specimens with Reference Diagnosis of LSIL+ (combined LSIL, ASC-H, HSIL, and Cancer) and 910 specimens with Reference Diagnosis of (combined NILM, ASC-US, and AGUS).

In this table, “Positive” means LSIL+ or UNSAT, and “Negative” means NILM or ASC-US/AGUS. All percentages are rounded to the nearest 0.1%.

LSIL+	Positive Percent Agreement			Negative Percent Agreement		
	Imager-Assisted (95% CI)	Manual (95% CI)	Difference (95% CI)	Imager-Assisted (95% CI)	Manual (95% CI)	Difference (95% CI)
#1	93.9% (215/229) (90.0% to 96.3%)	90.0% (206/229) (85.4% to 93.2%)	3.9% (9/229) (-0.5% to 8.5%)	86.1% (509/591) (83.1% to 88.7%)	85.3% (504/591) (82.2% to 87.9%)	0.8% (5/591) (-1.7% to 3.5%)
#2	85.0% (278/327) (80.7% to 88.5%)	88.1% (288/327) (84.1% to 91.2%)	-3.1% (-10/327) (-7.0% to 0.8%)	87.4% (795/910) (85.0% to 89.4%)	87.7% (798/910) (85.4% to 89.7%)	-0.3% (-3/910) (-2.3% to 1.6%)
#3	93.9% (307/327) (90.7% to 96.0%)	87.5% (286/327) (83.4% to 90.6%)	6.4% (21/327) (3.2% to 10.0%)	84.3% (767/910) (81.8% to 86.5%)	84.6% (770/910) (82.1% to 86.8%)	-0.3% (-3/910) (-2.4% to 1.7%)
Combined	90.6% (800/883) (88.5% to 92.4%)	88.3% (780/883) (86.0% to 90.3%)	2.3% (20/883) (0.1% to 4.5%)	85.9% (2071/2411) (84.5% to 87.2%)	85.9% (2072/2411) (84.5% to 87.3%)	0.0% (-1/2411) (-1.3% to 1.2%)

Table 19: Laboratory Imager-Assisted Review Results vs. Laboratory Manual Review Results for the Specimens with Reference Diagnosis of ASC-H+

In the study, there were 147 specimens with Reference Diagnosis of ASC-H+ (combined ASC-H, HSIL, and Cancer) and 1,090 specimens with Reference Diagnosis of (combined NILM, ASC-US/AGUS, and LSIL).

In this table, "Positive" means ASC-H+ or UNSAT, and "Negative" means NILM, ASC-US/AGUS, or LSIL. All percentages are rounded to the nearest 0.1%.

ASC-H+	Positive Percent Agreement			Negative Percent Agreement		
Lab CT/ Pathologist	Imaged (95% CI)	Manual (95% CI)	Difference (95% CI)	Imaged (95% CI)	Manual (95% CI)	Difference (95% CI)
#1	93.7% (104/111) (87.6% to 96.9%)	88.3% (98/111) (81.0% to 93.0%)	5.4% (6/111) (-0.6% to 12.0%)	86.7% (615/709) (84.0% to 89.0%)	86.7% (615/709) (84.0% to 89.0%)	0.0% (0/709) (-2.2% to 2.2%)
#2	86.4% (127/147) (79.9% to 91.0%)	86.4% (127/147) (79.9% to 91.0%)	0.0% (0/147) (-6.8% to 6.8%)	89.4% (974/1090) (87.4% to 91.1%)	89.4% (975/1090) (87.5% to 91.1%)	-0.1% (-1/1090) (-1.8% to 1.6%)
#3	95.2% (140/147) (90.5% to 97.7%)	89.8% (132/147) (83.8% to 93.7%)	5.4% (8/147) (-0.1% to 11.4%)	88.2% (961/1090) (86.1% to 90.0%)	87.4% (953/1090) (85.3% to 89.3%)	0.7% (8/1090) (-1.0% to 2.5%)
Combined	91.6% (371/405) (88.5% to 93.9%)	88.1% (357/405) (84.6% to 90.9%)	3.5% (14/405) (0.0% to 7.0%)	88.3% (2550/2889) (87.0% to 89.4%)	88.0% (2543/2889) (86.8% to 89.2%)	0.2% (7/2889) (-0.8% to 1.3%)

Table 20: Laboratory Imager-Assisted Review Results vs. Laboratory Manual Review Results for the Specimens with Reference Diagnosis of HSIL+

In the study, there were 110 specimens with Reference Diagnosis of HSIL+ (combined HSIL and Cancer) and 1,127 specimens with Reference Diagnosis of (combined NILM, ASC-US/AGUS, LSIL, and ASC-H).

In this table, "Positive" means HSIL+ or UNSAT, and "Negative" means NILM, ASC-US/AGUS, LSIL, or ASC-H. All percentages are rounded to the nearest 0.1%.

HSIL+	Positive Percent Agreement			Negative Percent Agreement		
Lab CT/ Pathologist	Imaged (95% CI)	Manual (95% CI)	Difference (95% CI)	Imaged (95% CI)	Manual (95% CI)	Difference (95% CI)
#1	90.7% (78/86) (82.7% to 95.2%)	80.2% (69/86) (70.6% to 87.3%)	10.5% (9/86) (2.9% to 18.8%)	86.8% (637/734) (84.1% to 89.0%)	89.1% (654/734) (86.6% to 91.2%)	-2.3% (-17/734) (-4.6% to -0.1%)
#2	80.9% (89/110) (72.6% to 87.2%)	74.5% (82/110) (65.7% to 81.8%)	6.4% (7/110) (-2.0% to 14.7%)	92.1% (1038/1127) (90.4% to 93.5%)	92.3% (1040/1127) (90.6% to 93.7%)	-0.2% (-2/1127) (-1.7% to 1.4%)
#3	90.9% (100/110) (84.1% to 95.0%)	82.7% (91/110) (74.6% to 88.7%)	8.2% (9/110) (0.7% to 16.0%)	89.0% (1003/1127) (87.0% to 90.7%)	89.7% (1011/1127) (87.8% to 91.3%)	-0.7% (-8/1127) (-2.4% to 0.9%)
Combined	87.3% (267/306) (83.1% to 90.5%)	79.1% (242/306) (74.2% to 83.3%)	8.2% (25/306) (3.7% to 12.7%)	89.6% (2678/2988) (88.5% to 90.7%)	90.5% (2705/2988) (89.4% to 91.5%)	-0.9% (-27/2988) (-1.9% to 0.1%)

In the study, there were 1.83% (23/1260) ThinPrep 5000 slides with UNSAT results by Adjudication.

Agreement among Laboratory Cytotechnologists/Pathologists

The following tables indicate the extent to which the laboratory Cytotechnologists/Pathologists at a given site agreed amongst themselves on the diagnosis, comparing the Imager-assisted review to the manual review. Tables are provided for ASC-US+ and ASC-H+. Note that since one site had only two CT/Pathologist pairs, the three-way agreement analysis is available for just two sites, with 840 total specimens.

In *Table 21* for ASC-H+, the number of specimens is shown for which various levels of agreement among the CTs occurred. Either all three CTs rated the slide as positive (ASC-H+), two out of three rated it positive, one out of three, or none of them.

Table 21: Laboratory Cytotechnologist/Pathologist Agreement, All Results, ASC-H+

		Manual Review Three lab CTs have read the same slide				Totals
		ASC-H+	Three CTs had ASC-H+	Two CTs had ASC-H+ & one had <ASC-H	One CT had ASC-H+ & two had <ASC-H	
Imager-Assisted Review Three lab CTs have read the same slide	Three CTs had ASC-H+	91	23	8	0	122
	Two CTs had ASC-H+ and one had <ASC-H	12	21	7	8	48
	One CT had ASC-H+ and two had <ASC-H	3	12	16	11	42
	Three CTs had <ASC-H	0	2	22	604	628
Totals		106	58	53	623	840

		Manual Review Three lab CTs have read the same slide		Totals
		ASC-H+	Three or two CTs had ASC-H+	
Imager-Assisted Review Three lab CTs have read the same slide	Three or two CTs had ASC-H+	147	23	170
	Three or two CTs had <ASC-H	17	653	670
Totals		164	676	840

The rate of agreement between the Imager-assisted review result and the manual review result from the previous table is presented below. PPA is the positive percent agreement, percent of specimens of ASC-H+ diagnosis with Imager-assisted review by a majority of laboratory CT/Pathologists among all specimens of ASC-H+ diagnosis with manual review by a majority of laboratory CT/Pathologists. NPA is the negative percent agreement, percent of specimens of <ASC-H diagnosis with Imager-assisted review by a majority of laboratory CT/Pathologists among all specimens of <ASC-H diagnosis with manual review by a majority of laboratory CT/Pathologists.

Table 22: Rate of CT/Pathologist Agreement, ASC-H+

ASC-H+			
PPA	89.0%	(147/164)	(83.3% to 92.9%)
NPA	96.6%	(653/676)	(95.0% to 97.7%)

In *Table 23* for ASCUS+, the number of specimens is shown for which various levels of agreement among the CTs occurred. Either all three CTs rated the slide as positive (ASCUS+), two out of three rated it positive, one out of three, or none of them.

Table 23: CT Agreement, All Results, ASCUS+

		Manual Review Three lab CTs have read the same slide				Totals
		Three CTs had ASCUS+	Two CTs had ASCUS+ & one had <ASCUS	One CT had ASCUS+ & two had <ASCUS	Three CTs had <ASCUS	
Imager-Assisted Review Three lab CTs have read the same slide	Three CTs had ASCUS+	272	22	8	0	302
	Two CTs had ASCUS+ and one had <ASCUS	15	16	6	7	44
	One CT had ASCUS+ and two had <ASCUS	7	10	24	38	79
	Three CTs had <ASCUS	0	5	28	382	415
Totals		294	53	66	427	840

		Manual Review Three lab CTs have read the same slide		Totals
		Three or two CTs had ASCUS+	Three or two CTs had <ASCUS	
Imager-Assisted Review Three lab CTs have read the same slide	Three or two CTs had ASCUS+	325	21	346
	Three or two CTs had <ASCUS	22	472	494
Totals		347	493	840

The rate of agreement between the Imager-assisted review result and the manual review result from the previous table is presented below. PPA is the positive percent agreement, percent of specimens of ASCUS+ diagnosis with Imager-assisted review by a majority of laboratory CT/Pathologists among all specimens of ASCUS+ diagnosis with manual review by a majority of laboratory CT/Pathologists. NPA is the negative percent agreement, percent of specimens of <ASCUS diagnosis with Imager-assisted review by a majority of laboratory CT/Pathologists among all specimens of <ASCUS diagnosis with manual review by a majority of laboratory CT/Pathologists.

Table 24: Rate of CT Agreement, ASCUS+

ASCUS+			
PPA	93.7%	(325/347)	(90.6% to 95.8%)
NPA	95.7%	(472/493)	(93.6% to 97.2%)

H. Clinical Investigation Conclusions

- For all sites combined for ASCUS+, the improvement in sensitivity of the *Imager Review* method over the *Manual Review* method is statistically significant. This increase is 6.4% with a 95% confidence interval of 2.6% to 10.0% for all sites combined. The differences in sensitivity varied among the sites from -2.8% to +14.4%. For LSIL+ and HSIL+ the sensitivity of the *Imager Review* method is equivalent to the *Manual Review* method.
- For all sites combined for HSIL+, the improvement in specificity of the *Imager Review* method over the *Manual Review* method is statistically significant. This increase is 0.2% with a 95% confidence interval of 0.06% to 0.4% for all sites combined. The differences in specificity varied among the sites from -0.1% to +0.7%. For ASCUS+ and LSIL+ the specificity of the *Imager Review* method is equivalent to the *Manual Review* method.
- Specimen adequacy can be determined using the method described in Bethesda System 2001 or by having the Cytotechnologist count the cells in the 22 fields of view presented by the Imager.
- The workload limit for the ThinPrep Imaging System has been established at 200 slides in no less than an 8-hour workday. This workload limit of 200 slides includes the time spent for manual review of slides that is not to exceed 100 slides in an 8 hour workday.

For these clinical sites and these study populations, the data from the clinical trial and clinical support studies demonstrate that the use of the ThinPrep Imaging System to assist during primary screening of ThinPrep Pap Test slides for all cytologic interpretations, as defined by the Bethesda System, is safe and effective for the detection of cervical abnormalities.

Performance may vary from site to site as a result of differences in patient populations and reading practices. As a result each laboratory using this device should employ quality assurance and control systems to ensure proper use and selection of appropriate workload limits.

I. Bibliography

1. Solomon D., Davey D, Kurman R, Moriarty A, O'Connor D, Prey M, Raab S, Sherman M, Wilbur D, Wright T, Young N, for the Forum Group Members and the 2001 Bethesda Workshop. The 2001 Bethesda System Terminology for Reporting Results of Cervical Cancer. *JAMA*. 2002;287:2114-2119.
2. Kurman RJ, Solomon D. The Bethesda System for Reporting Cervical/Vaginal Cytologic Diagnoses. Springer-Verlag 1994.
3. Schafer, J.L. Multiple imputation: a primer. *Statistical Methods in Medical Research*, 1999, 8:3-15.
4. National Cancer Institute. SEER Cancer Statistics Review 1973-1998. Available at: <http://www.seer.cancer.gov>. Accessed February 2002.



Hologic, Inc.
250 Campus Drive
Marlborough, MA 01752 USA
1-800- 442-9892
www.hologic.com

AW-12515-001 Rev. 001
© 2015 Hologic, Inc. All rights reserved.

Table of Contents

Table of Contents



Table of Contents

Chapter One

INTRODUCTION

SECTION A: Overview and Function of the Review Scope	1.1
SECTION B: The ThinPrep® Imaging System Process	1.4
SECTION C: Specimen Preparation and Processing	1.6
SECTION D: Review Scope Technical Specifications	1.6
SECTION E: Internal Quality Control	1.13
SECTION F: Review Scope Hazards	1.13
SECTION G: Disposal	1.18

Chapter Two

INSTALLATION

SECTION A: General	2.1
SECTION B: Action Upon Delivery	2.1
SECTION C: Preparation Prior to Installation	2.1
SECTION D: Moving the Review Scope	2.2
SECTION E: Connecting Review Scope Components	2.3
SECTION F: Power On the Review Scope	2.7
SECTION G: Storage and Handling - Post Installation	2.10

Chapter Three

OPERATION OF THE REVIEW SCOPE

SECTION A: Overview	3.1
SECTION B: Materials Required Prior to Operation	3.5
SECTION C: Auto Review	3.6
SECTION D: Subsequent Review	3.16
SECTION E: Manual Slide Review	3.18
SECTION F: Shutting Down the Review Scope	3.24



Chapter Four

OPERATION OF THE SOFTWARE MENU

SECTION A: Introduction	4.1
SECTION B: Menu Option 1 Login/Logout	4.3
SECTION C: Menu Option 2 Joystick Calibration	4.4
SECTION D: Menu Option 3 Setup Marker	4.6
SECTION E: Menu Option 4 Preferences	4.13
SECTION F: Menu Option 5 Open Error Log	4.27
SECTION G: Menu Option 6 Usage Count	4.28

ThinPrep Review Scope Preferences Worksheet

Chapter Five

REVIEW SCOPE MAINTENANCE

SECTION A: Daily	5.1
SECTION B: General Cleaning	5.1
SECTION C: Replacing the Illuminator Light Bulb	5.2
SECTION D: Replacing the Fuses	5.5
SECTION E: Koehler Alignment	5.8

Chapter Six

TROUBLESHOOTING

SECTION A: Operation Errors	6.1
SECTION B: User-Correctable Errors	6.4
SECTION C: Recoverable System Errors	6.13
SECTION D: Miscellaneous	6.13

Chapter Seven

DEFINITIONS AND ABBREVIATIONS	7.1
--------------------------------------	-----

Chapter Eight

SERVICE INFORMATION	8.1
----------------------------	-----

Chapter Nine

ORDERING INFORMATION	9.1
-----------------------------	-----

INDEX

Chapter One

Introduction

SECTION A

OVERVIEW AND FUNCTION OF THE REVIEW SCOPE

The Review Scope is an automated microscope to be used by a cytotechnologist (CT) to screen ThinPrep® Pap Test slides that have been imaged by a ThinPrep Image Processor. The microscope uses standard microscope optics enhanced with automated features that facilitate review of the slide. The CT views the slide and by means of automatic stage movement, is presented with fields of view containing objects of interest identified by the Imaging System. A motorized nosepiece allows the CT to change magnification via a pod device, without interrupting visual observation of the slide. An automated slide marking system allows the CT to mark objects for further review by a pathologist. The Review Scope is networked to the imaging system and slide data is retrieved from and later updated and returned to a slide database maintained by the imaging system.

1 INTRODUCTION

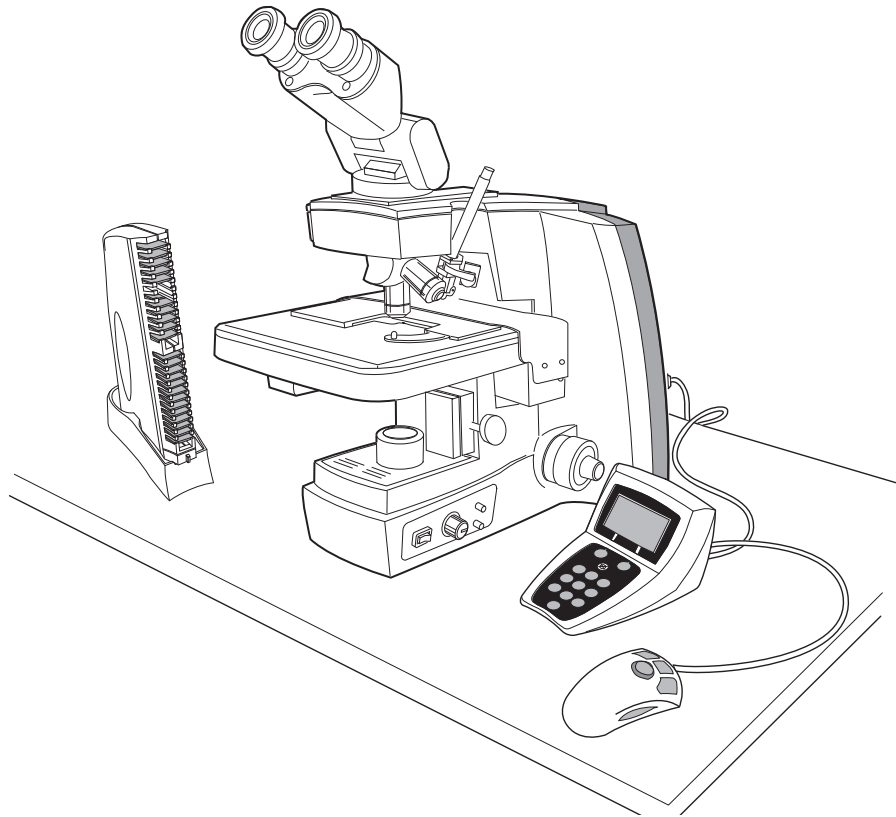


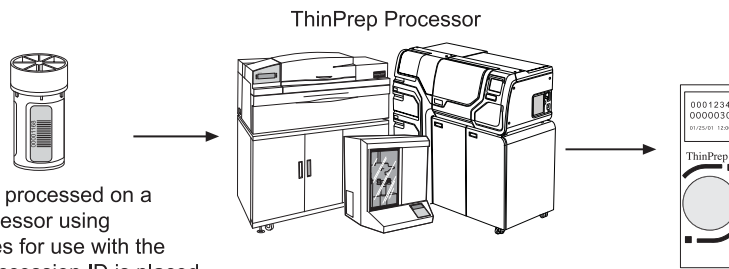
Figure 1-1 Review Scope

ThinPrep® Imaging System: Laboratory Flow



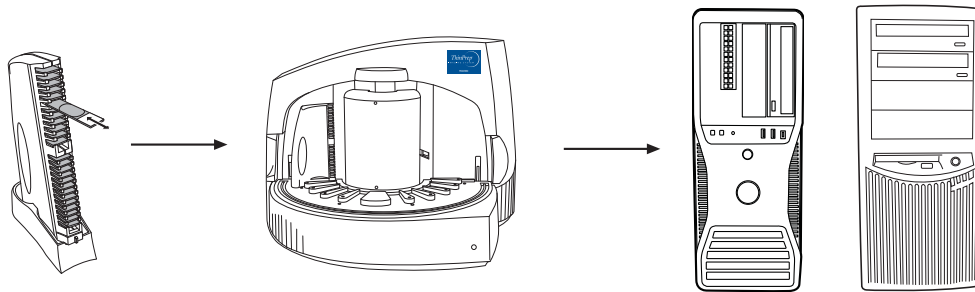
A request form and a ThinPrep Vial containing cervical specimen collected from the patient arrive at the laboratory.

A unique accession number is assigned and attached to each item.



The sample is processed on a ThinPrep processor using ThinPrep slides for use with the Imager. The accession ID is placed on the slide.

A ThinPrep processed slide contains the patient accession ID and cell samples.
The slide is then stained with ThinPrep Stain and cover slipped.



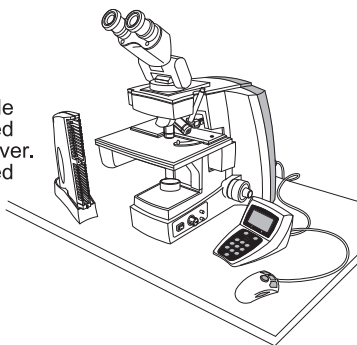
Prepared slides are loaded into cassettes, which are placed in the ThinPrep Imaging Station.

The Imaging Station scans the cell spot and sends the images to the Image Processor Controller (IPC).

The Image Processor Controller analyzes the images and identifies coordinates of Objects Of Interest (OOIs). These are sent to the Server.

The Server stores the slide data records for later review at the Review Scope.

At the Review Scope, the slide ID# is scanned and the related data is retrieved from the Server. 22 fields of view are presented to the CT via the review microscope. Suspect cells may be electronically marked by the CT during review.



At the conclusion of review, the slide is physically marked, to indicate it has been screened. Slides with marked target zones are reviewed by a Cytopathologist for interpretation and diagnosis.

All slides and patient data are ready to be filed.

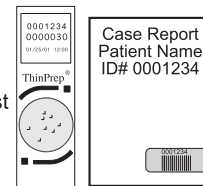


Figure 1-2 Lab Flow

1 INTRODUCTION

SECTION B

THE THINPREP® IMAGING SYSTEM PROCESS

Slides that have been prepared for screening are loaded into cassettes which are placed into the Imaging Station. The operator uses a PC keyboard, mouse and monitor to interact with the instrument via a graphic, menu driven interface.

A slide ID reader scans the slide accession ID and then the Imaging Station scans the entire ThinPrep cell spot. The system identifies objects of interest found on the slide, based on integrated optical density. (Refer to Figure 1-3, ThinPrep Imaging Process.) The coordinates of 22 of those objects are recorded and the slide is returned to its cassette. Following processing of each cassette of slides, the numeric slide ID and associated data record are sent to the Server.

The Server acts as the central data manager for the ThinPrep® Imaging System. As slides are imaged by the Image Processor and reviewed at the Review Scope, the Server stores, retrieves and transmits information based on the slide ID.

The Cytotechnologist (CT) reviews slides at the Review Scope (RS). The RS consists of elements of a standard microscope, augmented with automated capabilities for viewing and marking the microscope slides. The RS contains an optical scanner which reads the slide ID when a slide is loaded on the stage. When a valid slide accession ID has been identified at the RS, the Server sends the object of interest coordinates for that ID and the CT is presented with the 22 fields of view determined for that slide. It is required that the CT review each of these fields of view before completing a slide review.

As each field of view is being reviewed, the CT has the option to electronically mark the contents of the field for subsequent physical marking at completion of the slide review. The CT always has the option to control the position of the stage/slide manually, which provides complete freedom to move any portion of the ThinPrep cell spot into the field of view for examination.

Note: The object of interest is typically placed in the center of the field of view, however the CT *must* screen the entire field of each of the 22 fields of view presented.

Before completing the review, the CT may revisit any locations and mark or unmark fields of view, as desired. At the conclusion of electronically marking the slide, physical marks are applied at those locations with a semi-permanent translucent marker. A “slide reviewed” mark is placed on the slide at the end of the review, whether or not any physical marks were placed.

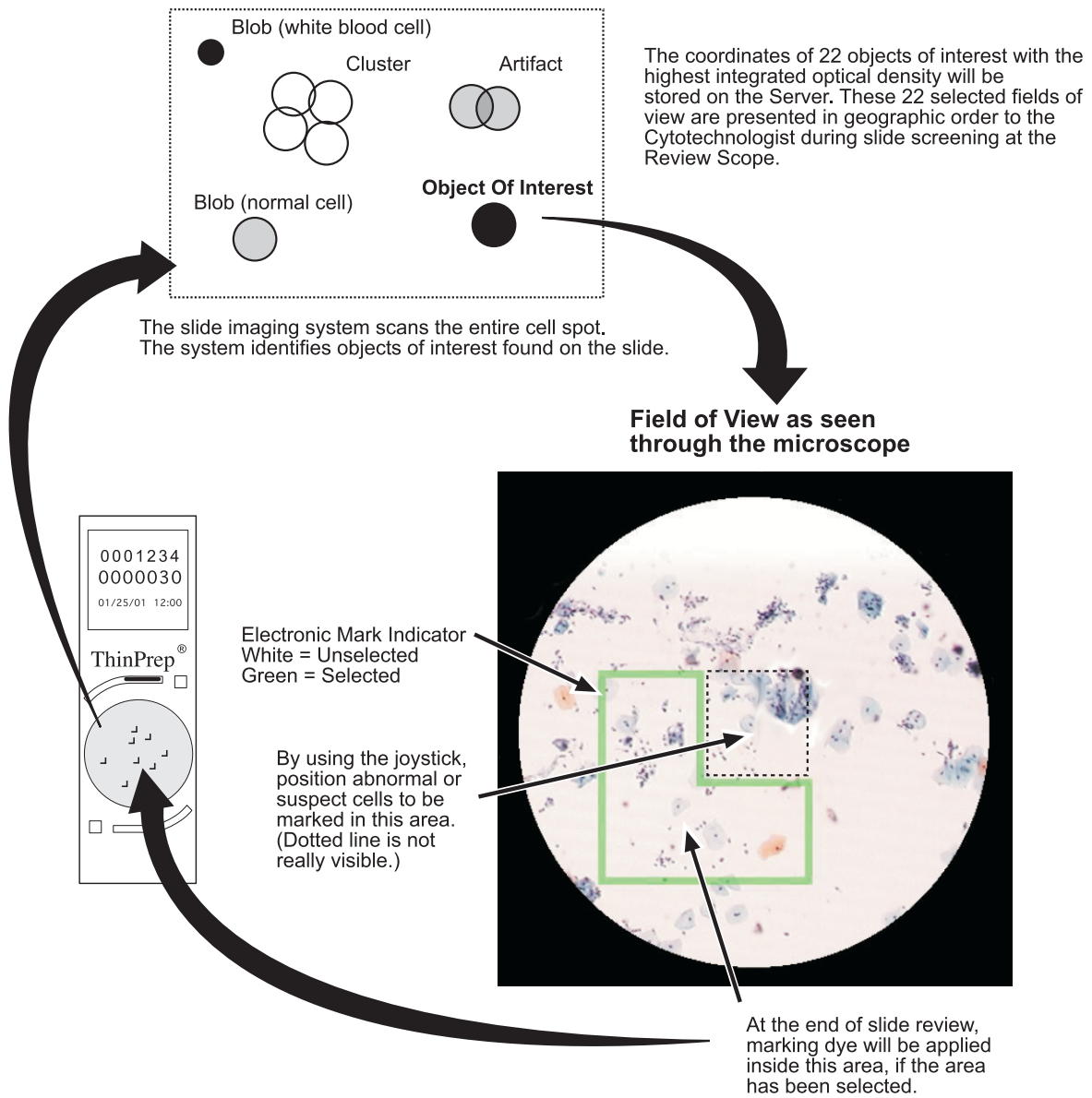


Figure 1-3 ThinPrep® Imaging Process

1 INTRODUCTION

SECTION C

SPECIMEN PREPARATION AND PROCESSING

Specimens for the ThinPrep® Pap Test cytology slide are collected by a clinician, then immersed and rinsed in a PreservCyt® Solution sample vial. The sample is then capped, labeled, and sent to a laboratory equipped with a ThinPrep Processor. The samples are processed on ThinPrep Imaging System slides. After being processed, the slides are stained with ThinPrep Stain.

Please refer to the Operator's Manuals of these instruments and stain for more information regarding preparation and processing of ThinPrep slides.

Specimen Handling and Stability

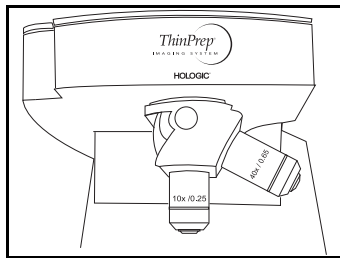
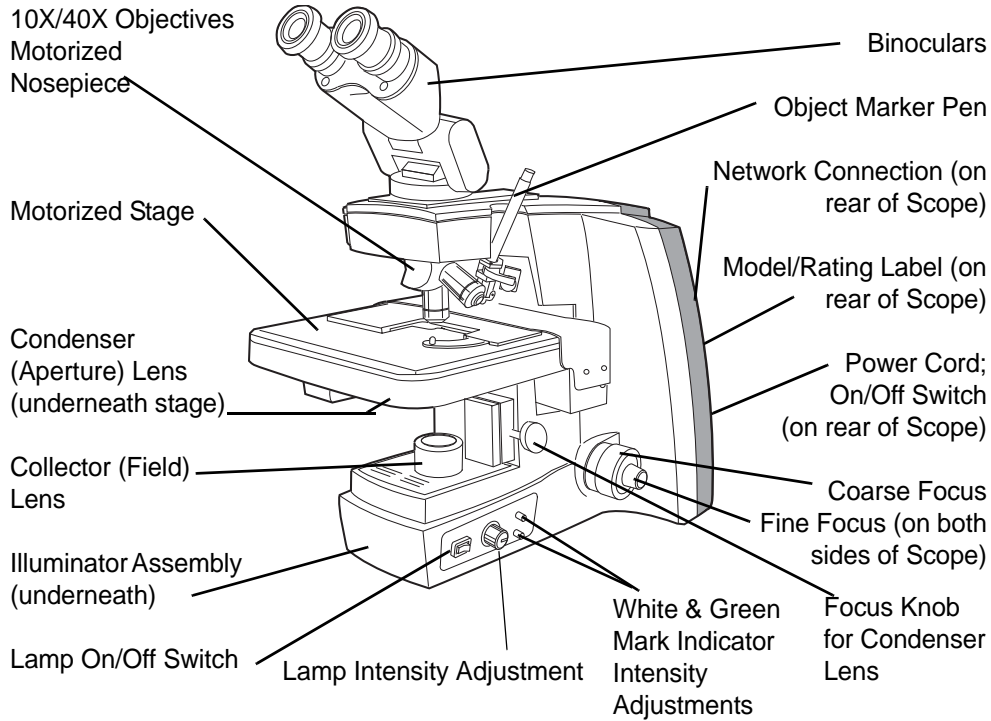
The ThinPrep slides are stored, transported and handled the same as conventional cytology slides. Please refer to your laboratory guidelines for specimen handling.

SECTION D

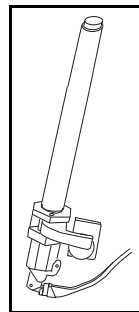
REVIEW SCOPE TECHNICAL SPECIFICATIONS

Overview of Components

Refer to Figure 1-4 to Figure 1-8 for information regarding components and specifications.



Motorized Nosepiece

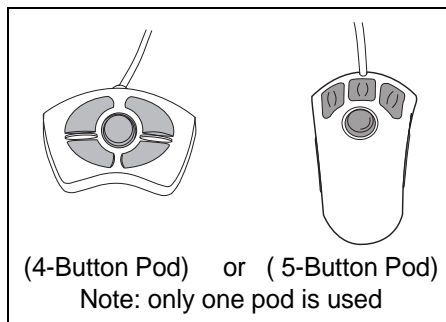


Motorized Object Marker Mechanism

Note: Certain models of the ThinPrep Review Scope (model numbers 70669-001, 70669-002, and 70669-003) require a different pen and special setup instructions. See "MENU OPTION 3 SETUP MARKER" on page 4.6.



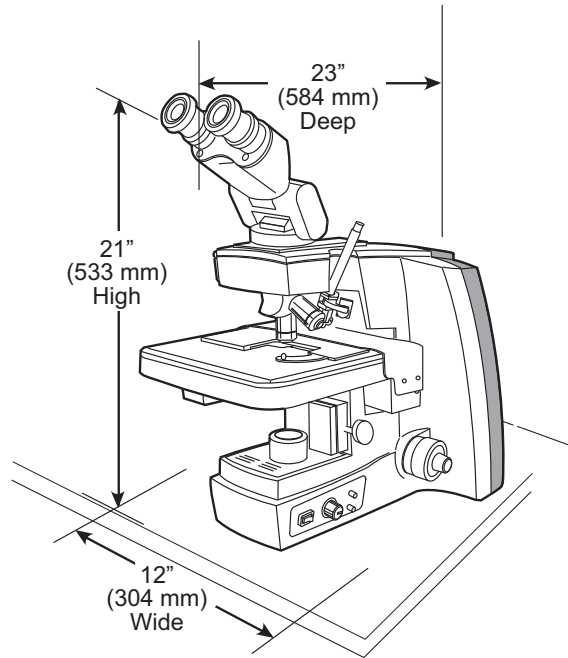
Console



Navigator Pod

Figure 1-4 Review Scope Components

Dimensions



Approximate Weight: 38 lbs (17.24 kg)

Figure 1-5 Review Scope Dimensions

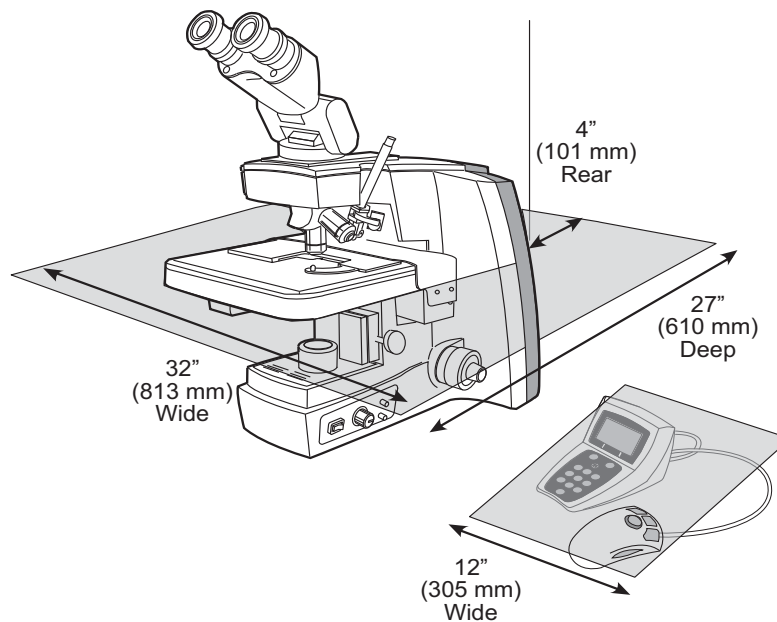


Figure 1-6 Recommended Clearances

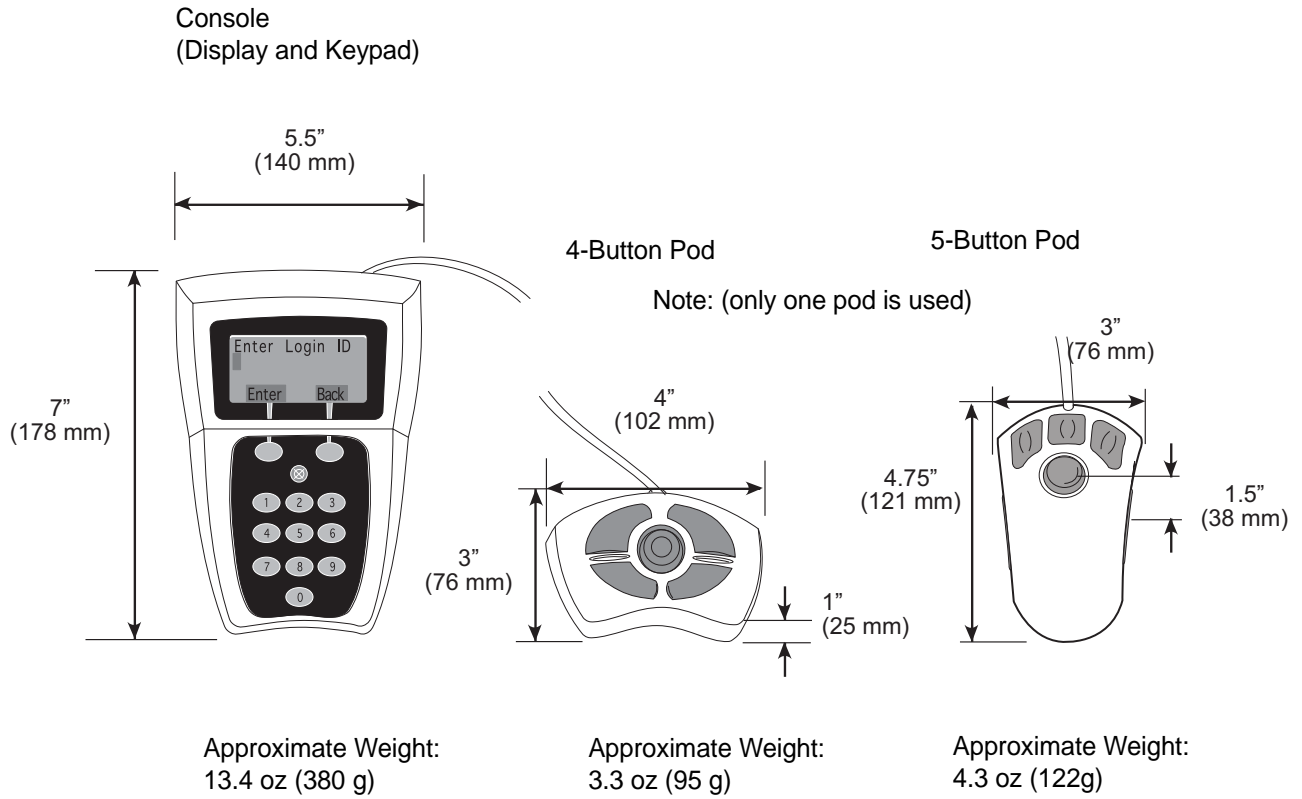


Figure 1-7 Console and Navigator Pod

ThinPrep® Microscope Slide for Use with the Imaging System

The ThinPrep microscope slide is used by the ThinPrep Processor in preparing the patient slide. The slide utilizes fiducial marks, or fixed reference points, which are permanently printed features on the slide that are used to register the slide position on the stage. A coordinate system is based on the fiducial marks, for locating objects of interest on the cell spot.

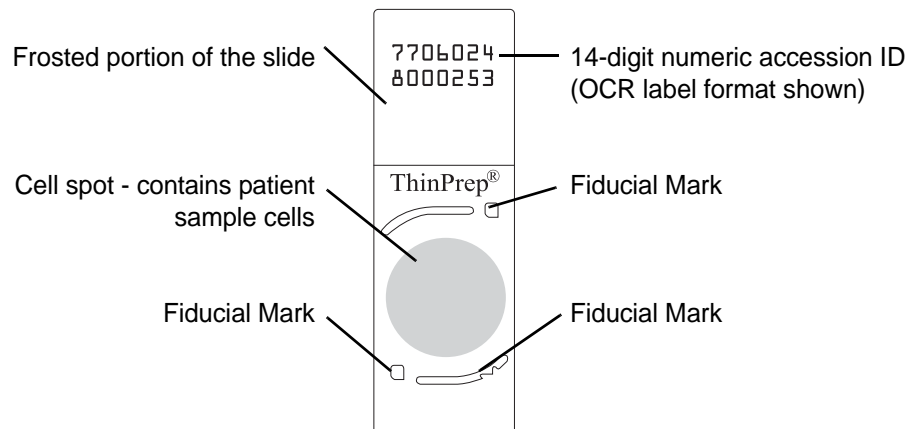


Figure 1-8 ThinPrep Microscope Slide

Slide Labeling Formats

The formats that the optical scanner on the Review Scope can read for the accession ID on the slide label are configured on the Imaging System server. Refer to the Image Processor Operator's Manual for specifications for slide label formats.

Environmental

Operating Temperature Range: (the Review Scope is plugged in and turned on.)

16°C to 32°C

Non-Operating Temperature Range: (the Review Scope is plugged in but not turned on)

-28°C to 50°C

Operating Humidity Range:

20 to 80% relative humidity, non-condensing

Non-Operating Humidity Range:

15 to 95% relative humidity, non-condensing

Pollution Degree II, in accordance with IEC 60664.

Category II. The ThinPrep Review Scope is for indoor use only in an office or a clean laboratory environment.

Altitude: 0 meters (sea level) to 2000 meters

Atmospheric Pressure: 1100 millibar to 500 millibar

Power

Voltage:

100-120 / 200-240~ (Volts alternating current, no selection required)

Mains supply voltage not to exceed $\pm 10\%$ of the nominal voltage

Frequency:

50-60 Hz

Power:

2A maximum

Heat Generated:

Approximately 600 BTU/HR (176W)

Fusing:

Two T2.5A, 250V, 5 x 20 mm, glass, time delay, low break capacity

F1 - 2.5A fused AC to 12V supply, located on Illumination Control Board

Protective Temperature Coefficient Devices

This unit contains protective temperature coefficient (PTC) devices intended for protection against occasional overcurrent or overtemperature fault conditions. These devices automatically reset after the overcurrent or overtemperature condition has been removed.

The PTCs locations and functions are as follows:

System Hardware Electromechanical Processor (SHEMP)

F1 - 1A PTC - 5V sensor power to sensor ports J4 and J5

F2 - 1A PTC - 5V sensor power to sensor ports J2 and J3

F3 - 1A PTC - Isolated 5V for the CAN BUS

F4 - 500ma PTC - 24V line to protect against motor or drive failure

Servo Interface Module (SERVIM)

R21 - 1.85A PTC - 24V line to protect FETS and motors

1 INTRODUCTION

Dimensions and Weight (Approximate)

Review Scope:

21" (533mm) H x 12" (304mm) W x 23" (584mm) D

38 lbs (17 kg)

Console:

3.5" (89mm) H x 5.5" (140mm) W x 7" (178mm) D

13.4 oz (380 g)

Navigator Pod:

4-button pod:

1" (25mm) H x 4" (102mm) W x 3" (76mm) D

3.3 oz (95 g)

5-button pod:

4.75" (121mm) H x 3" (76mm) W x 1.5" (38mm) D

4.3 oz (122 g)

Review Scope Standards

The ThinPrep® Review Scope has been tested and certified by a U.S. nationally recognized testing Laboratory (NRTL) to comply with current Safety, Electro-Magnetic Interference (EMI) and Electro-Magnetic Compatibility (EMC) standards. Refer to the product label, located on the rear of the instrument, to see the safety certification markings.

Do not use this device in close proximity to sources of strong electromagnetic radiation (e.g., unshielded intentional RF sources), as these may interfere with proper operation.

This product is *in vitro diagnostic* (IVD) medical equipment.

This product contains a device classified per EN 60825-1: 1994, Issue 2, June 1997 as a Class 1 LED Product.

SECTION
E

INTERNAL QUALITY CONTROL

Power On Self Test

When the Review Scope is powered on (refer to Power On the Review Scope page 2.7), the instrument goes through a self-diagnostic test. Electrical, mechanical and software systems are tested to confirm each functions properly. Network communication is tested at the time the user Logs In for an Auto Review session. The operator is alerted to any malfunction via a message on the console display.

If the system does not function, or there are persistent errors, contact Hologic Technical Support. (Refer to Service Information, Chapter 8.)

SECTION
F

REVIEW SCOPE HAZARDS

The Review Scope is intended to be operated in the manner specified in this manual. Be sure to review and understand the information listed below in order to avoid harm to operators and/or damage to the instrument.

If this equipment is used in a manner not specified by the manufacturer, then the protection provided by the equipment may be impaired.








Warnings, Cautions and Notes

The terms WARNING, CAUTION and Note have specific meanings in this manual.

- A **WARNING** advises against certain actions or situations that could result in personal injury or death.
- A **CAUTION** advises against actions or situations that could damage equipment, produce inaccurate data or invalidate a procedure, although personal injury is unlikely.
- A **Note** provides useful information within the context of the instructions being provided.

Symbols Used on the Instrument

The following is an explanation of the symbols that may appear on your product:

Symbol	Title	Description	Standard information
	Caution	Indicates the need for the user to consult the instructions for use for important cautionary information such as warnings and precautions that cannot, for a variety of reasons, be presented on the medical device itself.	ISO 15223-1 Medical devices—Symbols to be used with medical device labeling and information to be supplied, Section 5.4.4
	In vitro diagnostic medical device	Indicates a medical device that is intended to be used as an in vitro diagnostic medical device	ISO 15223-1 Medical devices—Symbols to be used with medical device labeling and information to be supplied, Section 5.5.1
	Authorized Representative in the European Community	Indicates the Authorized Representative in the European Community	ISO 15223-1 Medical devices—Symbols to be used with medical device labeling and information to be supplied, Section 5.1.2
	Serial number	Indicates the manufacturer's serial number so that a specific medical device can be identified	ISO 15223-1 Medical devices—Symbols to be used with medical device labeling and information to be supplied, Section 5.1.7
	Catalogue Number	Indicates the manufacturer's catalogue number so that the medical device can be identified	ISO 15223-1 Medical devices—Symbols to be used with medical device labeling and information to be supplied, Section 5.1.6
	Manufacturer	Indicates the medical device manufacturer, as defined in the EU Directives 90/385/EEC, 93/42/EEC and 98/79/EC	ISO 15223-1 Medical devices—Symbols to be used with medical device labeling and information to be supplied, Section 5.1.1
	Fuse	To identify fuse boxes or their location.	IEC 60417 Graphical symbols for use on equipment, symbol 5016




Symbol	Title	Description	Standard information
	Caution, hot surface	To indicate that the marked item can be hot and should not be touched without taking care	IEC 60417 Graphical symbols for use on equipment, symbol 5041
	Caution, risk of electric shock	To identify equipment that has risk of electric shock	IEC 60417 Graphical symbols for use on equipment, symbol 5042
	Protective earth; protective ground	To identify any terminal which is intended for connection to an external conductor for protection against electric shock in case of a fault, or the terminal of a protective earth (ground) electrode	IEC 60417 Graphical symbols for use on equipment, symbol 5019

Figure 1-9 Symbols used on the instrument

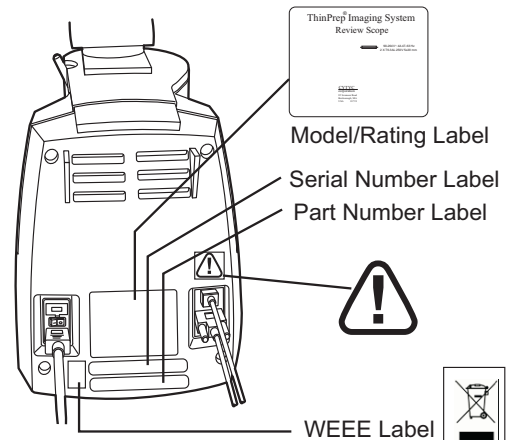
The Review Scope has symbols placed on it specifically to advise the operator to refer to the Operator's Manual. (Refer to Figure 1-10.) Be sure to review and understand the warnings listed below in order to avoid damage to the instrument and any harm to operators. One or more of the warnings may be pertinent to the area marked.

The instrument model/rating label and the serial number label are also located on the Review Scope.

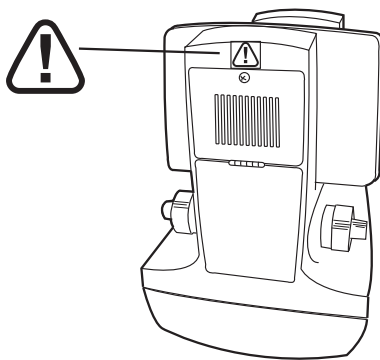
Location of Labels on the Instrument



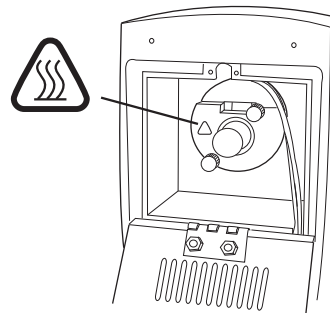
Motorized Stage
Crushing/Pinch Point
Moving Parts
Glass



Rear Of Scope
External Connections
Fusing
Grounded Outlet



Bottom, Exterior of Scope
Operator Access



Bottom, Interior of Scope
Hot Surfaces (the lightbulb
itself may be hot)

Figure 1-10 Label Locations

Warnings Used in this Manual:

WARNING

Service Installation Only

This instrument is to be installed by trained Hologic® personnel only.

WARNING

Instrument Fusing

For continued protection against fire, replace only with fuses of the specified type and current rating. Refer to the Review Scope Maintenance chapter for instructions on replacing user accessible fuses. Refer to Ordering Information for fuse specification and ordering.

WARNING

Moving Parts

The instrument contains moving parts. Keep hands, hair, loose clothing, jewelry, etc., clear.

WARNING

Grounded Outlet

To ensure safe operation of the instrument, use a three-wire grounded outlet.

WARNING

Glass

The instrument uses microscope slides, which have sharp edges. In addition, the slides may be broken in their storage packaging or on the instrument. Use caution when handling glass slides and when cleaning the instrument.

1 INTRODUCTION

WARNING

Hot Surfaces

The microscope contains hot surfaces. Use extreme caution when handling items near these surfaces. Allow hot surfaces to cool before handling. The light bulb contained in the collector housing may be hot.

SECTION G DISPOSAL

Disposal of Consumables

Marking Pens. No special instructions; used marking pens may be disposed of in your laboratory refuse.

Halogen light bulbs. No special instructions; used light bulbs may be disposed of in your laboratory refuse.

Instrument fuses. No special instructions; used fuses may be disposed of in your laboratory refuse.

Disposal of the Device

Please contact Hologic Service (refer to Service Information, Chapter 8).

Do not dispose in municipal waste.

Please contact Hologic Technical Support.



Hologic, Inc.
250 Campus Drive
Marlborough, MA 01752 USA
Tel: 1-800-442-9892
1-508-263-2900
Fax: 1-508-229-2795
Web: www.hologic.com

Chapter Two

Installation

WARNING: Service Installation Only

SECTION

A

GENERAL

The ThinPrep[®] Review Scope must be installed by Hologic Service Personnel. When installation is complete, Hologic personnel trains the operator(s), using the Operator's Manual as the training guide.

SECTION

B

ACTION UPON DELIVERY

Remove and read the *Operating Instructions Prior to Installation* sheet attached to the packing carton.

Inspect the packing cartons for damage. Report any damage immediately to the shipper and/or Hologic Technical Support as soon as possible. (Refer to Service Information, Chapter 8.)

Leave the instrument in the packing cartons for Hologic Service installation.

Store the instrument in a suitable environment until installation (cool, dry, vibration-free area).

SECTION

C

PREPARATION PRIOR TO INSTALLATION

Pre-Installation Site Assessment

A pre-installation site assessment is performed by Hologic Service Personnel. Be sure to have prepared any and all site configuration requirements as instructed by the Service personnel.

Location And Configuration

Review Scopes connected to the Server may be local or up to 200 meters (656 feet) away. Room for the console and Navigator Pod that accompany each review scope should be accommodated, as well as a comfortable amount of desk space for placing slide cassettes, flats or other slide containers. (Refer to Figure 2-1.)

2 INSTALLATION

CAUTION: Route connections carefully to avoid pinching the cables. To avoid tripping over, or disconnecting cabling, do not place cabling near foot traffic.

The Review Scope is sensitive to vibrations. It should be placed on a flat, sturdy surface away from any vibrating equipment.

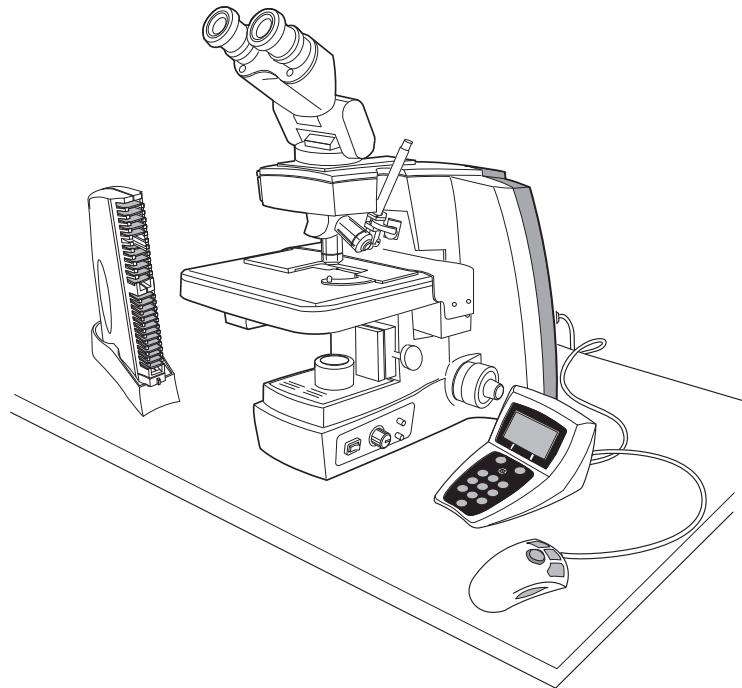


Figure 2-1 A Typical Review Scope

SECTION D

MOVING THE REVIEW SCOPE

The Review Scope is a precision instrument and should be handled with care. If the microscope must be moved, it should be grasped and lifted by the frame housing. (Refer to Figure 2-2.) Lifting the instrument by the motorized stage will cause damage to the microscope and may render it inoperable.

If the Review Scope is to be shipped to a new location, please contact Hologic Technical Support. (Refer to Service Information, Chapter 8.)

CAUTION: Do not lift or handle the Review Scope by the stage. Do not rest the stage against your body, as this may misalign the stage.

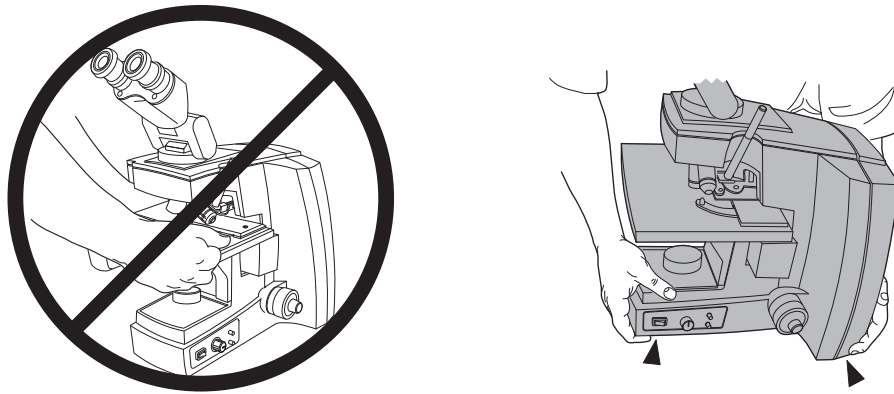


Figure 2-2 Moving the Review Scope

SECTION
E

CONNECTING REVIEW SCOPE COMPONENTS

The Review Scope provides electrical and software interface for the display console and the control pod. The microscope is connected to the Server via an ethernet cable to receive and transmit slide data, user preferences and other data for report generation.

The power cord (refer to Figure 2-3) provides electrical power to the Review Scope. It must be plugged into a 3-prong grounded outlet. Disconnection from the power supply source is by removal of the power cord.

- The network connection (refer to Figure 2-3) connects the Review Scope to the hub, enabling communication to the Server located in the Image Processor Controller.
- The console connection is used to interface the console and pod to the Review Scope. The operator interfaces with the Review Scope via these peripheral devices.
- The service port (refer to Figure 2-3) is to be used only by trained Hologic personnel for service and diagnostic purposes.

2 INSTALLATION

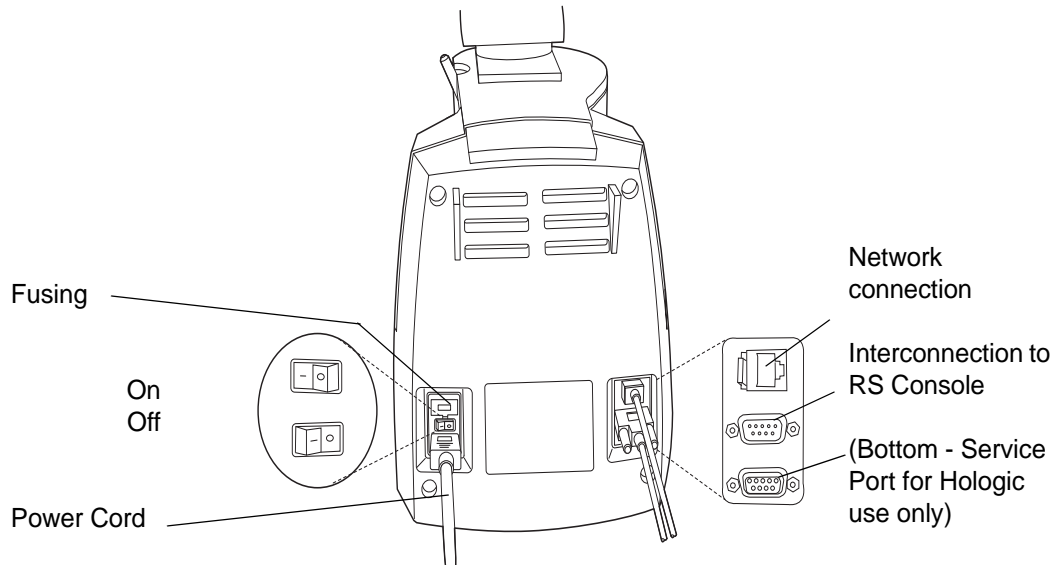


Figure 2-3 Review Scope, Rear

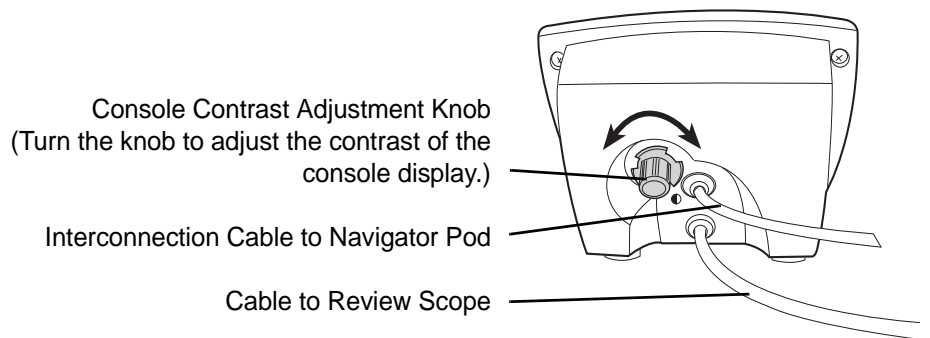


Figure 2-4 Console, Rear

Console and Navigator Pod

Connect the console unit to the Review Scope by plugging the end of the serial cable into the middle right port on the rear of the microscope. Plug the other end of the cable into the rear of the console.

The console and pod may be placed on either side of the microscope, depending on user preference. The connection cord between them is short, so they must be located together.

The network connection cable from the Server snaps into an available port on the hub or switch. Another cable goes from the hub to the Review Scope, snapping into the connection jack at the top port on the rear of the Scope. (Refer to Figure 2-3.)

CAUTION: Only the optional accessories listed in Table 9.2 may be used with the Review Scope.

Binocular Head

The Review Scope is supplied with a standard, tilting binocular head. (Refer to Figure 2-5.)

Hologic has evaluated the use of an optional riser and an optional telescoping binocular head with the Review Scope. The specific riser and head that may be used are listed in Table 9.1. Contact Hologic Technical Support for more information on the installation of these items.

CAUTION: Only use Hologic supplied eyepieces and objective lenses. DO NOT substitute eyepieces or lenses.

Eyepieces

The 10X eyepieces slide into their mounting holes in the binoculars. (Refer to Figure 2-5.)

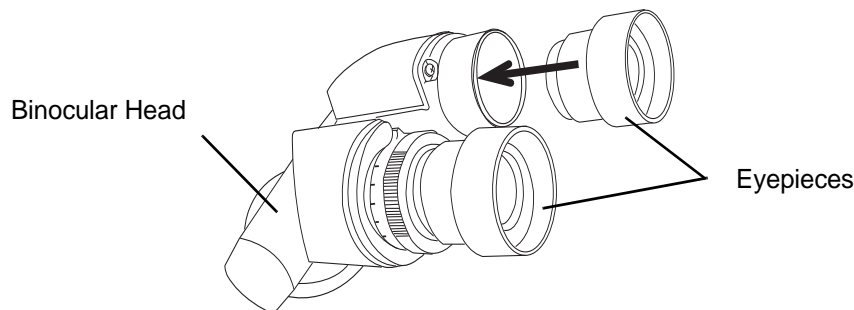


Figure 2-5 Binocular Head With Eyepieces

Objectives

The 10X and 40X objective lenses are mounted in the motorized nosepiece on the microscope at the factory.

If an objective must be replaced, an optical alignment is required. Please contact Hologic Technical Support.

2 INSTALLATION

Marking Pen

CAUTION: The marking pen should ONLY be loaded by performing the Calibrate Marker function via the software menu.

Certain models of the ThinPrep Review Scope (model numbers 70669-001, 70669-002, and 70669-003) require a different pen and special setup instructions.

The marking pen for some models of the ThinPrep Review Scope is a Sharpie® Ultra Fine Point marking pen. Only use this specified marker for ThinPrep Review Scope model numbers 70575-001, 70575-003, 71062-001, and 71062-002. (Refer to Figure 2-6.)

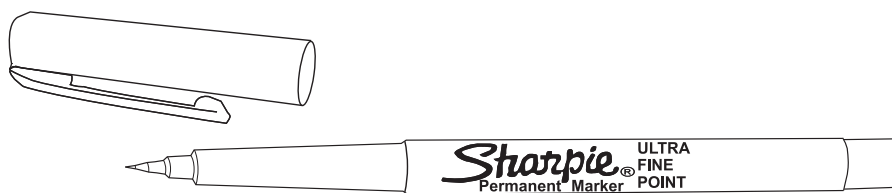


Figure 2-6 Sharpie® Marking Pen

The marking pen for the other models of the ThinPrep Review Scope is a Pilot Extra Fine Point marking pen. Only use this specified marker for ThinPrep Review Scope model numbers 70669-001, 70669-002, and 70669-003. (Refer to Figure 2-7.)



Figure 2-7 Pilot Marking Pen

The marking pen must be present for physical marking of the slide at the conclusion of a review. Loading the marking pen should **only** be done by executing “Calibrate Marker” from the Review Scope software menu. (Refer to Marker Calibration on page 4.8.)

Focus Knob Covers

Rubber knob covers for the fine focus knobs are available. They are placed over the focus knob and remain in place via a friction fit. (Refer to Figure 2-8.) Contact Hologic Technical Support to request them.

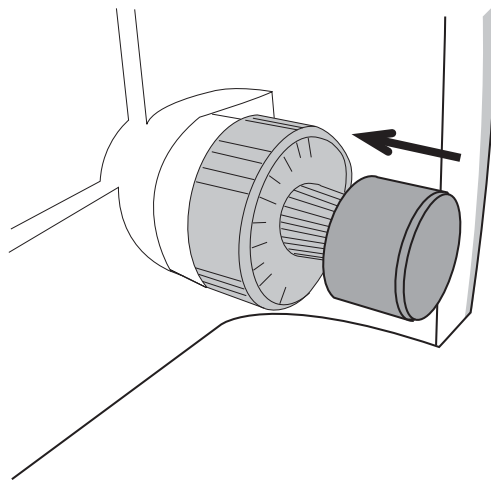


Figure 2-8 Focus Knob Covers

SECTION
F

POWER ON THE REVIEW SCOPE

The Review Scope power On/Off switch is located at the rear of the microscope. Confirm that it is in the Off position and plug the receptacle end of the power cord into the socket. Plug the other end of the power cord into a wall outlet. To ensure safe operation of the microscope, a three wire grounded outlet must be used. (Refer to Figure 2-9.)

WARNING: Grounded Outlet
Instrument Fusing

Do not power on or operate if equipment has been damaged.

To ensure network communication necessary to operate the automated Review Scope for auto review, the server must be powered on and initialized. The Review Scope may be turned on at any time. Entering a valid Login ID will make a network connection if the server is available.

Power on the Review Scope by pressing the rocker switch on the rear of the scope to On. An audible beep will be heard as the unit powers up. It takes less than a minute for the microscope to become ready for use.

Note: Disconnection from power supply source is by removal of the power cord.

2 INSTALLATION

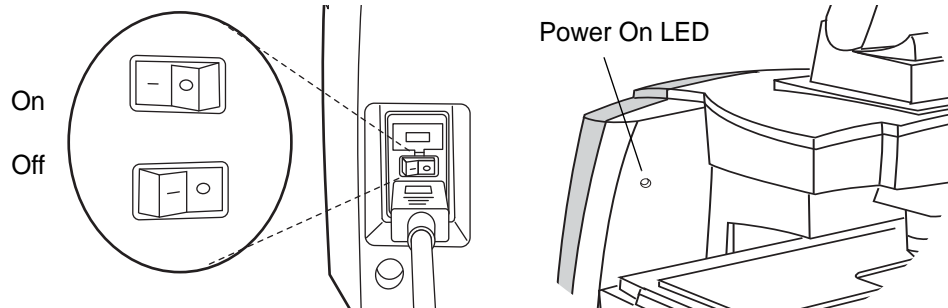
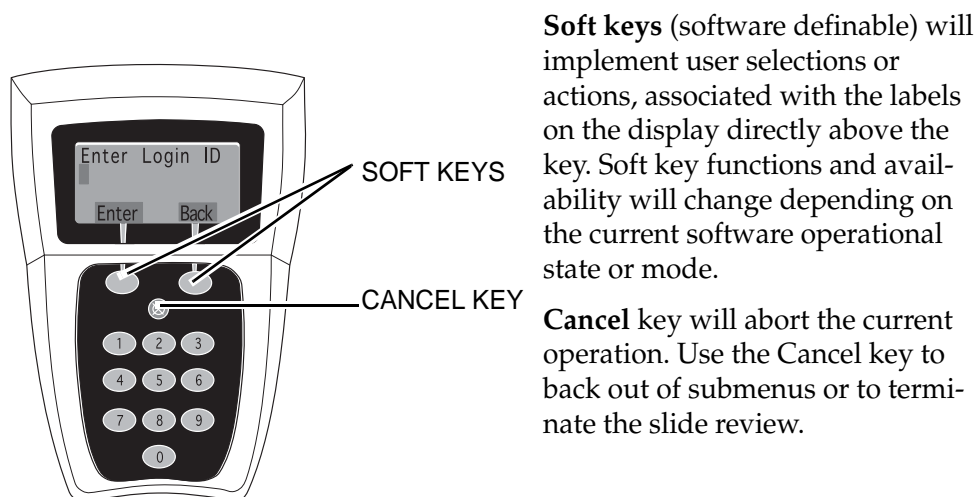


Figure 2-9 Power Entry Module and On/Off Switch

Allow the microscope to initialize. The instrument is ready for operation when the display on the console shows **Enter Login ID [Offline]**. (Refer to Figure 2-10.)



Soft keys (software definable) will implement user selections or actions, associated with the labels on the display directly above the key. Soft key functions and availability will change depending on the current software operational state or mode.

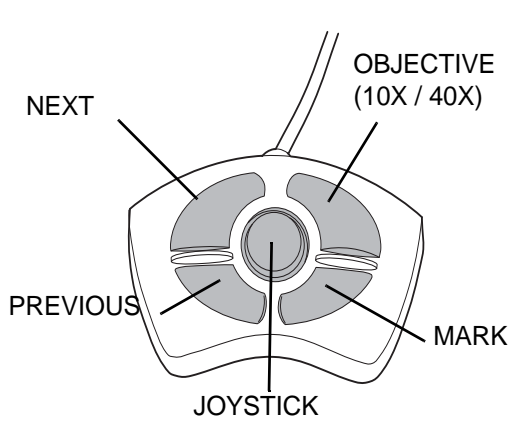
Cancel key will abort the current operation. Use the Cancel key to back out of submenus or to terminate the slide review.

Figure 2-10 Console Keypad and Display

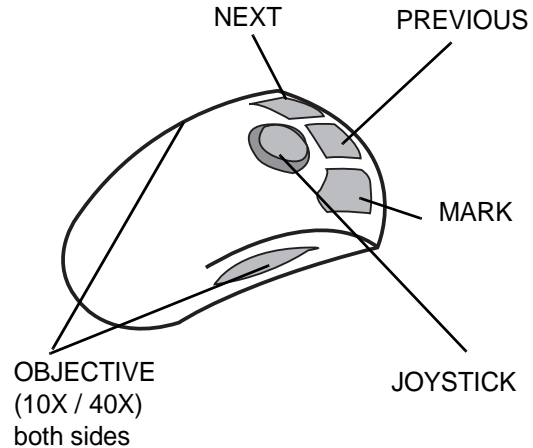
The Navigator Pod connects to the Review Scope, through the console. The pod is ready for use as soon as **Load Slide** is displayed on the console.

Figure 2-11 Pod (Default Button Configuration)

Next	used to advance through functions used to pause /resume stage motion during scan used to adjust user preference settings
Previous	used to return to fields of view during review used to adjust user preference settings
Objective	used to toggle between 10x and 40x magnification



4-BUTTON POD



5-BUTTON POD

Note: Only one pod is used.

- Mark** used to electronically mark or unmark cells for dotting by the marking pen
- Joystick** used for directional and velocity control of the motorized stage during slide review
used to increase or decrease stage speed during autoscan

Note: The Navigator Pod button functions are illustrated showing the default configuration. The Next, Previous, Objective and Mark functions can be assigned by the user. Refer to page 4.24, Button Setup.

At the control panel on right side of the microscope, turn the lamp power rocker switch to the “on” position. Adjust the illumination to the desired intensity by turning the lamp intensity adjustment dial.

The white and green mark indicator intensities may be set individually by turning their respective adjustment knobs. (Refer to Figure 2-12.)

Koehler illumination may be adjusted using the condenser and collector assemblies. Instructions for making this adjustment may be found in the Koehler Alignment section on page 5.8.

2 INSTALLATION

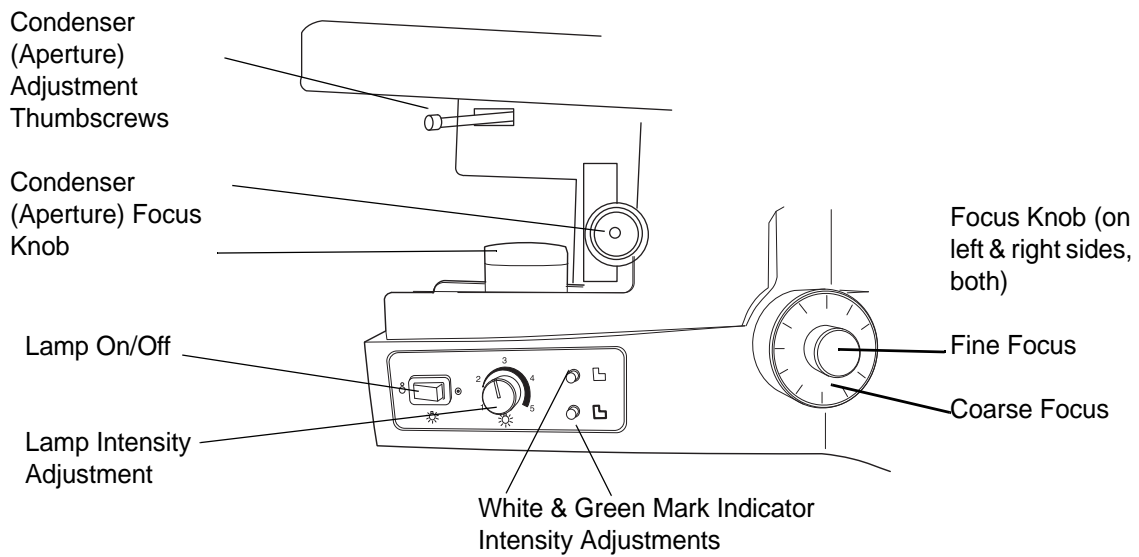


Figure 2-12 Illumination Control Panel

SECTION G

STORAGE AND HANDLING - POST INSTALLATION

The Review Scope may be stored in the location where it was installed. When it is not in use, the power should be turned off. Cover the instrument with the microscope dust cover.

Chapter Three

Operation of the Review Scope

SECTION**A****OVERVIEW**

ThinPrep® Pap Test cervical cytology sample slides processed by the ThinPrep Imaging System are reviewed at the Review Scope (RS). Slide review by a cytotechnologist is assisted by automated features. (Refer to Figure 3-1 for typical slide review process.)

Auto Review

In this manual, Auto Review refers to a slide review in which the RS

- scans the ID number from the slide
- communicates with the server for appropriate slide data record
- makes use of the Autolocate function (where the 22 fields of view identified by the Image Processor are presented to the cytotechnologist, CT)
- makes use of the Autoscan function, as required or desired
- uploads slide data record to the server at conclusion of slide review

Subsequent Review

A slide that has undergone Auto Review may be reviewed again, making use of the Autolocate, review and Autoscan functions. Further marks may be added (to a maximum of 30 marks on a slide), but no previous marks may be removed. The slide data record will be revised at the Server at the conclusion of the review.

Note: Slides previously screened either via auto review or manually may always be examined again in manual mode.



OPERATION OF THE REVIEW SCOPE

Manual Review

Manual Review refers to a slide review in which

- patient slide data is not retrieved from or communicated to the server
- a scan of the entire cell spot is conducted by the operator initiating each movement of the stage
- marks may be made (up to 30), but no record is stored on the server

(Refer to Figure 3-1 for a graphical representation of the typical slide review process.)

Important Operational Notes

CAUTION: Never lift or handle the Review Scope by the stage. (Refer to Figure 2-2, Moving the Review Scope.)

Calibrate the 4-button pod Joystick and the Object Marker once a day, in that order. (Refer to page 4.4 and page 4.6, respectively.)

Calibrate the 5-button pod joystick upon installation of the pod, or if the pod has been removed and then reinstalled on a Review Scope. (Refer to page 4.4.)

Load the slide properly, seated fully against the back and left guides, to ensure a successful slide ID scan and accurate positioning of Object of Interest coordinates sent from the Server. (Refer to Figure 3-2.)

Always examine the **entire** Field of View. Mark if you see any suspect object and then do Autoscan.

Daily Cytotechnologist Screening Rates

Laboratorians should use the following method when calculating workload:

- All slides with Fields of View (FOV) only review count as 0.5 or ½ slide
- All slides with full manual review (FMR) using the Autoscan feature count as 1 slide (as mandated by CLIA'88 for manual screening)
- Then, slides with **both** FOV and FMR count as 1.5 or 1½ slides
- Use these values to count workload, not exceeding the CLIA maximum limit of 100 slides in no less than an 8-hour day.

FMR = 1 slide
 FOV = 0.5 slide
 FMR + FOV = 1.5 slides
 Upper Limit = 100 slides

- **Note:** ALL laboratories should have a clear standard operation procedure for documentation of their method of workload counting and for establishing workload limits.
- It is the responsibility of the Technical Supervisor to evaluate and set workload limits for individual cytotechnologists based on laboratory clinical performance. According to CLIA '88, these workload limits should be reassessed every six months.

For less than an 8-hour workday, the following formula must be applied to determine the maximum number of slides to be reviewed during that workday:

$$\frac{\text{Number of hours examining slides}}{8} \times 100$$

The ThinPrep Imaging System limit of 100 slides in an 8-hour workday includes the following:

- Screening 22 Fields of View
- Full manual slide review using the Autoscan feature
- Review clinical history
- Record results and triage appropriately

The manual workload limit does not supersede the CLIA requirement of 100 slides in no less than an 8-hour day. Manual review includes the following types of slides:

- Slides reviewed on the ThinPrep Imaging System using the Autoscan feature
- Slides reviewed without the ThinPrep Imaging System
- Non-gynecologic slides.

When conducting manual review, refer to the CLIA requirements for calculating workload limits.

3

OPERATION OF THE REVIEW SCOPE

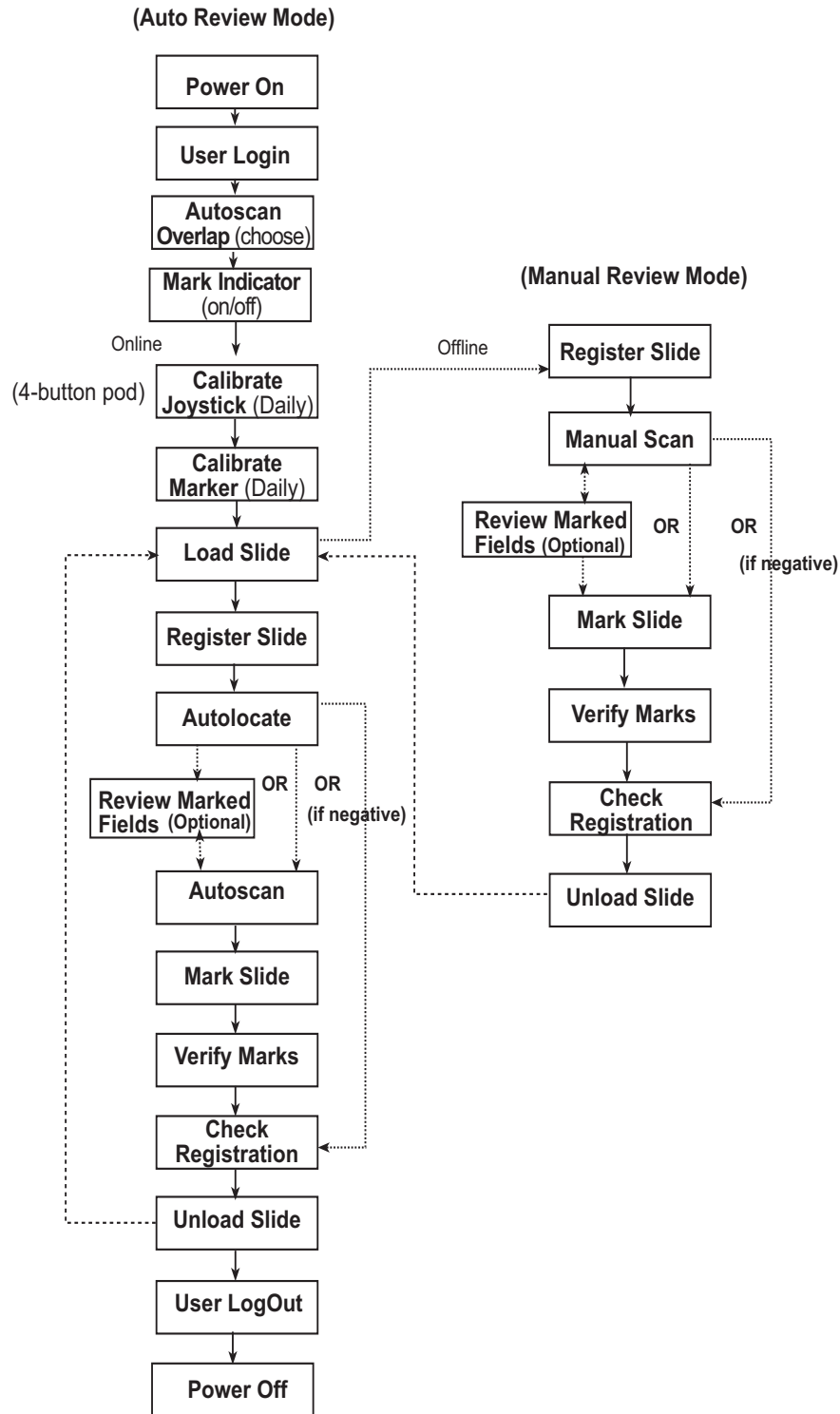


Figure 3-1 Typical Slide Review Process

**SECTION
B****MATERIALS REQUIRED PRIOR TO OPERATION**

ThinPrep[®] Pap Test slides imaged by the Image Processor are necessary to begin slide review.

A Sharpie[®] Ultra Fine Point marking pen or a Pilot Extra Fine point marking pen is used for physically marking the slides, depending on the model of ThinPrep Review Scope you have. If a pen is not already installed, refer to instructions on page 4.6 for installing the pen. (A box of pens is provided at instrument installation.)

3

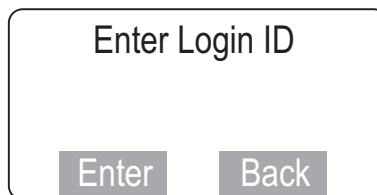
OPERATION OF THE REVIEW SCOPE

SECTION C

AUTO REVIEW

Login

To login, enter the three-digit User Login ID via the console keypad. Press the **Enter** soft key to Login. Pressing the **Back** soft key will perform a backspace/delete function. The **Cancel** console key will cancel the Login process.

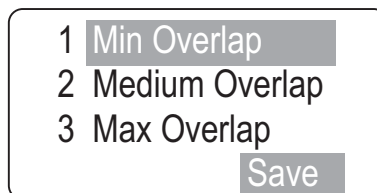


Each cytotechnologist (CT) must use a unique Login ID. That ID becomes part of the slide data record for each slide screened by the CT. Each Login ID is associated with the CT's RS options preferences. The preferences are downloaded from the Server to any RS the CT logs onto. (Refer to setting preferences on page 4.13.)

Note: See your lab administrator for any issues regarding Login ID's. Also, refer to the ThinPrep Image Processor's Operator's Manual.

Scan Overlap

An autoscan overlap must be selected. This sets how much the fields of view overlap from row to row during autoscan of the cell spot.



Select the scan overlap:

- minimum
- medium
- maximum

AUTO REVIEW (continued)

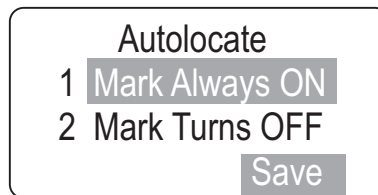
Mark Indicator

The white mark indicator may be turned off during autolocate, scan or review mode, when fields of interest are presented to the CT.

If it is preferred that the mark indicator always be visible during slide review, select **Mark Always ON**. Press **1** on the keypad and then press the **Save** softkey.

If it is preferred that the mark indicator is not visible during slide review, select **Mark Turns OFF**. Press **2** on the keypad and then press the **Save** softkey. The white mark indicator will remain off until the operator moves the joystick or presses the Mark button.

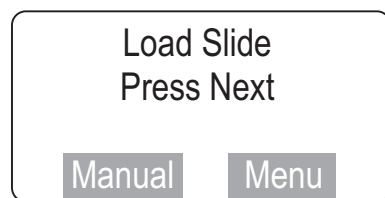
Note: the green mark indicator is unaffected by the preference setting.



Load Slide

WARNING: Glass
Moving Parts

The Load Slide display will appear on the console.



The Manual soft key will activate the manual review mode. Refer to page 3.2 for manual review.

The Menu soft key will display page 1 of the RS software menu.

To proceed with Auto Review, load a slide into the slide holder on the stage by rotating the slide clamp arm open far enough to allow placement of a slide in the holder. The slide should have the ID label face up, to the left. Gently release the arm against the slide.

Make sure the left and back edges of the slide are firmly positioned against the guides of the slide holder. (Refer to Figure 3-2, Loading a Slide.)

CAUTION: Inspect the slide before loading.

Confirm it is a clean, properly labeled ThinPrep® Pap Test slide.

Check for any damage. Do not load a slide onto the stage upside down.

3

OPERATION OF THE REVIEW SCOPE

AUTO REVIEW (continued)

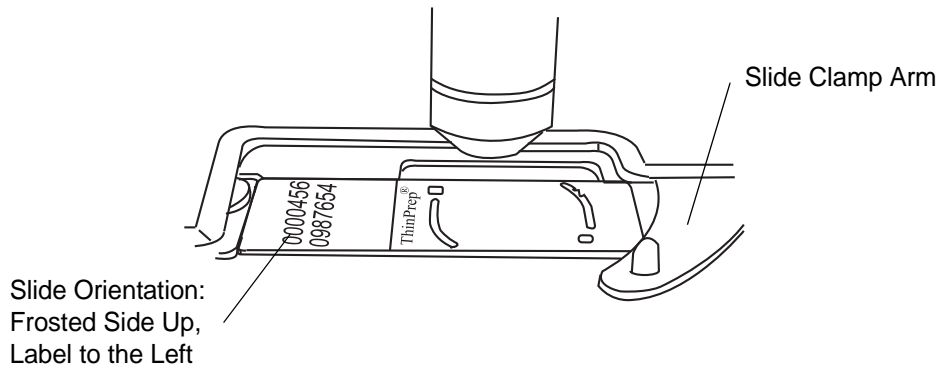


Figure 3-2 Loading a Slide

Press the **Next** button on the pod. A flash of red light and a beep will indicate that the slide accession ID has been scanned.

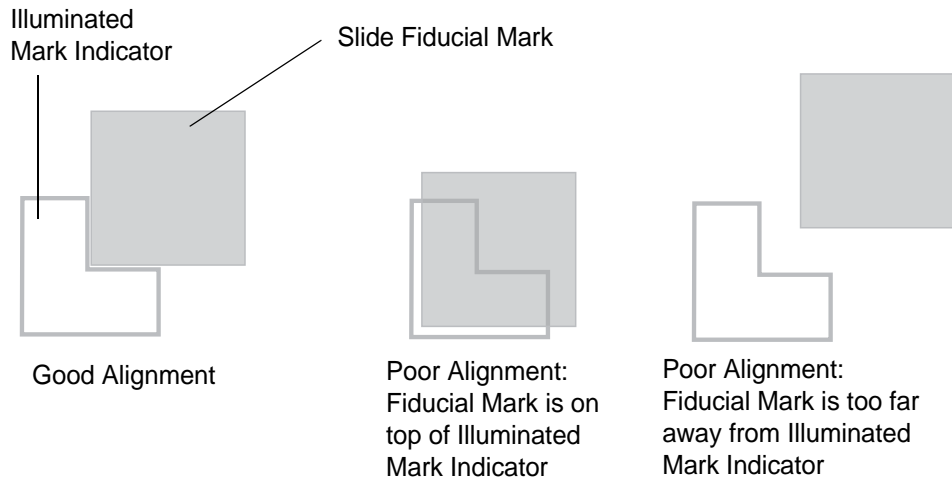
Note: If the slide reader cannot read the numeric slide ID, you may have to manually enter the slide ID number or manually review the slide. (Refer to "Text Messages on the Console Display" on page 6.1.)

Register the Slide Fiducial Marks

The stage will move the slide to present the first fiducial mark in the field of view. The display on the console prompts to align the first mark.

Align 1st Mark
Press Next

Using the joystick on the Navigator Pod, manipulate the view of the slide fiducial mark to align it against the inner edge of the illuminated mark indicator. The left and bottom edges of the fiducial mark should register with the inside of the 'L' mark. Bring the fiducial mark into sharp focus. (Refer to Figure 3-3.)

AUTO REVIEW (continued)**Figure 3-3 Align the Fiducial Mark and the Mark Indicator**

When the fiducial mark is aligned with the mark indicator, press the **Next** button on the pod. The stage presents the second mark and the display prompts the user to align the second fiducial mark.

Align 2nd Mark
Press Next/Prev

Using the joystick control, align the second fiducial mark with the illuminated mark indicator, as necessary. (Pressing the **Prev** button will allow re-alignment of the first fiducial mark, in case a mistake was made.) Press the **Next** button on the pod when satisfied with the alignment.

The third fiducial mark is presented and the display prompts the user to align the third mark.

Align 3rd Mark
Press Next/Prev

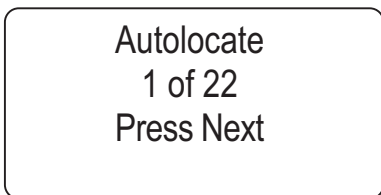
Using the joystick control, align the third fiducial mark with the illuminated mark indicator, as necessary. Press the **Next** button on the pod.



AUTO REVIEW (continued)

Autolocate - Viewing the Slide

The stage moves to present the first field of view to the operator.



Note: The intensity of the mark indicator may be adjusted by using the knobs on the illumination control panel. The upper knob adjusts the intensity of the white light and the lower knob adjusts the intensity of the green light. (Refer to "Illumination Control Panel" on page 2.10.)

Focus as needed using the focus knobs on either side of the Review Scope.

CAUTION: Scan the entire field of view.

Visually scan the entire field of view. The coordinates of the Object of Interest place it in the center of the field of view, yet the entire field must be examined.

The system does not determine specimen adequacy; use your standard lab protocol. To estimate the cellularity of the preparation in scanty cellular specimens, a specimen adequacy check can be performed during a review of the 22 fields of view. This is done by counting the cells presented in each of the 22 fields of view presented by the ThinPrep® Imaging System. The chart below lists the requirements for the average number of cells in each field dependent upon the microscope objective used:

		FN 22 Eyepiece/ 10X Objective		FN 22 Eyepiece/ 40X Objective	
PREP DIAM mm	AREA	Total Number of Fields	Number of Cells per Field for 5,000 Total	Total Number of Fields	Number of Cells per Field for 5,000 Total
20	314.2	82.6	60.5	1322	3.8

Autolocate presents in geographic order the 22 fields of interest as identified by the Image Processor to the CT for review. During review, the operator may:

- Focus, as necessary
- Move among the fields of view by pressing the **Next** and **Previous** buttons on the pod
- Move the field of view by manipulating the joystick
- Change the objective magnification by using the **Objective** button
- Add and remove electronic marks by using the **Mark** button
- Press the **Cancel** key to cancel review at any time

AUTO REVIEW (continued)

To proceed to the next field of view, press the **Next** button on the pod. Press the **Prev** button on the pod to go back to the previous field of view (unless you are at the first one). If the objective is at 40X when the **Next** or **Prev** button is pressed, the objective will automatically return to 10X before proceeding.

The object(s) of interest are not necessarily presented in the exact center of the field of view. The joystick can be used to move the stage for viewing and to position an abnormality in the target zone of the mark indicator for electronic marking. **Screen the entire field of view!**

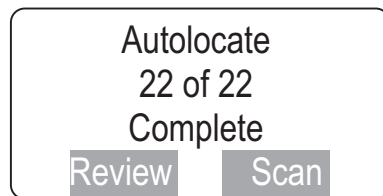
Note: Be sure to position the object so that the physical mark will not obscure it.

Press the **Objective** button on the pod to toggle between 10X and 40X magnification.

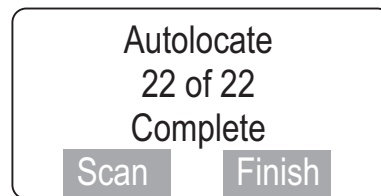
Press the **Mark** button on the pod to electronically 'tag' an area for physical marking at the conclusion of slide review. The mark indicator highlight will turn from white to green when it has been selected. Pressing the **Mark** button a second time will cause the mark indicator to turn from green to white and the electronic mark to be removed.

Note: Electronic marking can only be done while at 10X. The mark indicator is not visible at 40X.

When all 22 fields have been viewed, an audible beep will sound. The console display indicates the Autolocate function is complete.



This is displayed if one or more electronic marks were made. Proceed with the next section.



This is displayed if no electronic marks were made. (Scan of the cell spot is optional.) Proceed with Check Slide Registration.

After all 22 fields of view have been presented, the stage will position the field of view at the top edge of the cell spot.

3

OPERATION OF THE REVIEW SCOPE

AUTO REVIEW (continued)

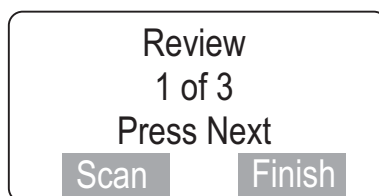
To estimate the cellularity of the preparation in scanty cellular specimens, a specimen adequacy check can be also performed. In accordance with Bethesda 2001 criteria¹, a minimum of 10 fields should be counted along a diameter of the cell spot that includes the center. Dependent upon the microscope objective used, use the chart below and count the average number of cells in each field. If this step is necessary, use the joystick to traverse the cell spot.

PREP DIAM mm	AREA	FN 22 Eyepiece/ 10X Objective		FN 22 Eyepiece/ 40X Objective	
		Total Number of Fields	Number of Cells per Field for 5,000 Total	Total Number of Fields	Number of Cells per Field for 5,000 Total
20	314.2	82.6	60.5	1322	3.8

¹The Bethesda System For Reporting Cervical Cytology, Second Edition, 2004, 1994 Spring Science and Business Media, LLC.

Review Marked Fields

If areas on the slide were electronically marked, they may be reviewed prior to scanning the slide. This function is optional and does not have to be done to complete the slide review procedure. To review marks, press the **Review** soft key.



The display lists how many electronic marks were made. Similar to operation of the Autolocate function, the Review Marks function allows the operator to:

- Move among electronic marks using the **Next** and **Prev** buttons on the pod
- Move the field of view by manipulating the joystick
- Change the objective magnification by pressing the **Objective** button
- Add and remove electronic marks by using the **Mark** button

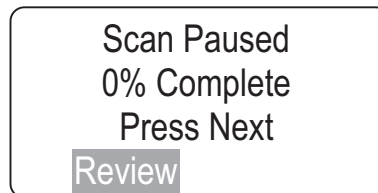
All marks are presented at 10X magnification. The objective will be returned to 10X prior to advancing to the next location. When the desired marks have been reviewed, press the **Scan** soft key to proceed to slide scanning.

AUTO REVIEW (continued)**Slide Scanning**

CAUTION: Autoscan must be done if any electronic marks have been made.

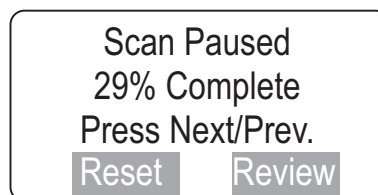
The slide may be scanned whether any electronic marks have been made or not. **If any electronic marks have been made, the entire slide *must* be scanned.** The Review Scope has an Autoscan function, enabling scan coverage of the entire cell spot. User preferences regarding method of scan, direction of scan and speed of scan may be customized in the preference menu. Preferences for scan mode must be set up ahead of time, in the user preference menu. (Refer to setting preferences on page 4.13.)

Slide scanning must be performed to complete slide review if electronic marks have been made.



To proceed with Autoscan, press the **Next** button on the pod. The motorized stage will present the entire cell spot in a defined path at 10X objective.

For Automatic Continuous or Automatic Start/Stop scan modes, to pause while scanning the slide, press the **Next** button on the pod. The stage motion will cease.



The operator may:

- Press the **Review** soft key to review electronic marks, (electronic marks may be added or deleted)
- Press the **Reset** soft key to start the scan at the beginning
- Press the **Prev** button on the pod to go back to the previous field of view (only on Automatic Start/Stop option; only goes back one field of view)

CAUTION: If the stage drifts (movement without touching the joystick), a joystick calibration should be performed. Refer to page 4.4.

- *During scan*, move the joystick left to slow the scan speed, right to increase the scan speed. (The speed remains until the scan ends, or the joystick is moved again.)
- *During pause*, move the joystick to view a different area of the slide

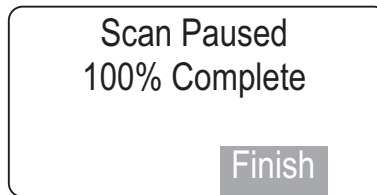
3

OPERATION OF THE REVIEW SCOPE

AUTO REVIEW (continued)

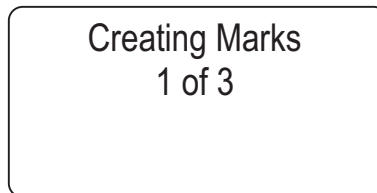
- Press the **Next** button on the pod to resume scanning (from the location where the scan left off)

An audible beep indicates the completion of scanning. The display shows Scan Paused, 100% Complete.

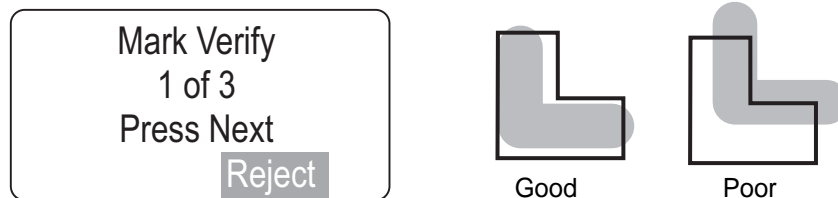


Physical Marking of the Slide

Press the **Finish** soft key. Any electronic marks will be physically marked on the cover slip with the marker pen. The display indicates marking activity (the number of marks depends on how many were electronically marked during review):

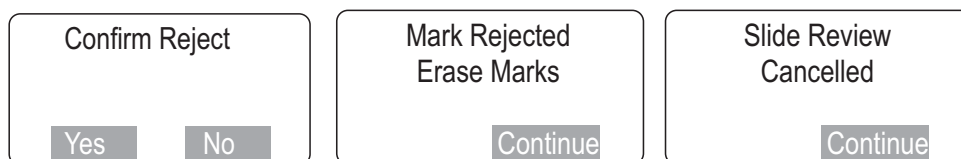


When the physical marks have been made, they are presented for final approval. This is to ensure that the physical marks coincide with the electronic marks.



If the physical mark is acceptable, press the **Next** button on the pod to continue.

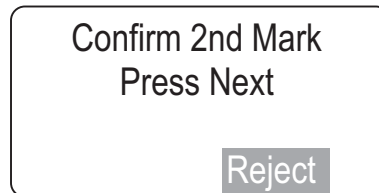
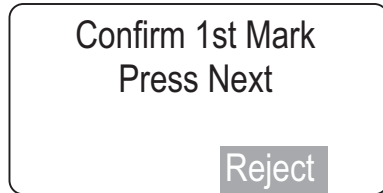
If the mark is not acceptable, press the **Reject** soft key. The display prompts to confirm the reject and to erase pen marks on the slide. Review of the slide is canceled.



AUTO REVIEW (continued)

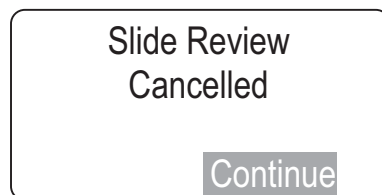
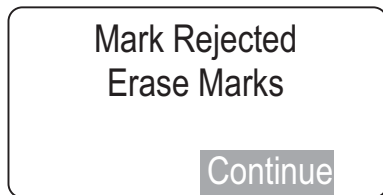
Check the Slide Registration

If all of the physical marks have been accepted, the stage positions the slide to show the first fiducial mark. The slide registration is checked to confirm that there has been no slide movement or loss of stage position during slide review.



If the fiducial mark is aligned with the illuminated mark indicator, press the **Next** button on the pod. If the second fiducial mark is properly aligned, press the **Next** button.

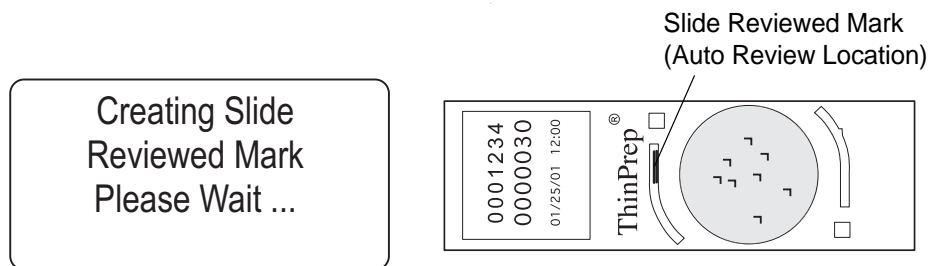
If the fiducial mark is not aligned, press the **Reject** soft key. The display prompts to erase pen marks on the slide and the review of the slide is canceled.



Creating the Slide Reviewed Mark

If the slide registration is acceptable, upon pressing the **Next** button on the pod, the slide data is sent to the Server, including the serial number of the review station, operator ID, date/time of the slide review, slide-review-complete status, coordinates of any marks that were made.

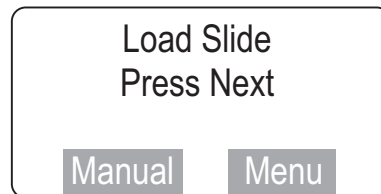
The stage positions the slide to receive the Slide Reviewed Mark. The marker pen is uncapped and a small double line is marked on the coverslip, located near the top arc of the slide. This indicates that a slide has completed the entire Auto Review process.



3

OPERATION OF THE REVIEW SCOPE

An audible beep indicates the mark has been created. The display indicates slide review is complete. The slide may be removed from the slide holder. The Load Slide screen is displayed and the Review Scope is ready for another slide review.



Logout When Finished

When finished reviewing slides, logout to save your preferences settings. (Refer to Menu Option 1 Login/Logout, page 4.3.)

SECTION D

SUBSEQUENT REVIEW

A slide that has undergone Auto Review may be reviewed again.

- More marks may be added (up to a total of 30 marks on any slide)
- No previous marks can be eliminated
- Up to 10 subsequent reviews may be performed

To conduct a subsequent review:

Power On - same as Auto Review.

User Login - same as Auto Review.

Load Slide - same as Auto Review. A "Slide Already Reviewed" message will display, because the slide data record in the server database indicates a previous review has taken place.



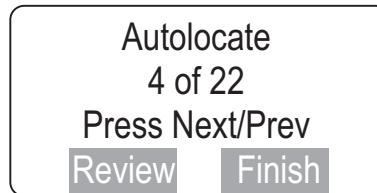
If you do not wish to do a Subsequent Review, press the **Cancel** soft key on the console.

Press the **Continue** soft key.

Register Slide - same as Auto Review.

SUBSEQUENT REVIEW (continued)

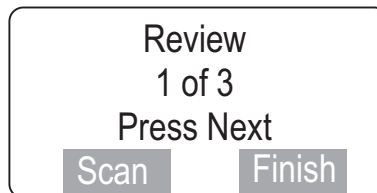
Autolocate - same as Auto Review. Notice that the soft keys are **Review** and **Finish**.



Because the entire slide has been screened previously [at least once], you may skip to review or finish at any time. If scanning the slide is desired, press the **Review** soft key.

Review Marked Fields - same as Auto Review

If additional electronic marks are made, the display will increase the tally to show total number of electronic marks associated with that slide. Any newly marked fields will be presented first, then marked fields from the previous review(s).



Autoscan - same as Auto Review.

Physically Marking the Slide - same as Auto Review. Only new marks are made on the slide.

Verify Marks - same as Auto Review, EXCEPT you will not be prompted to erase marks if the marks are rejected.

Check Registration - same as Auto Review, EXCEPT you will not be prompted to erase marks if the fiducial mark alignment is rejected.

Creating Slide Reviewed Mark - Not performed. Only the initial slide review will create the slide reviewed mark.

Unload Slide - same as Auto Review.

Logout When Finished

When finished reviewing slides, logout to save your preferences settings. (Refer to Menu Option 1 Login/Logout, page 4.3.)

3

OPERATION OF THE REVIEW SCOPE

SECTION E

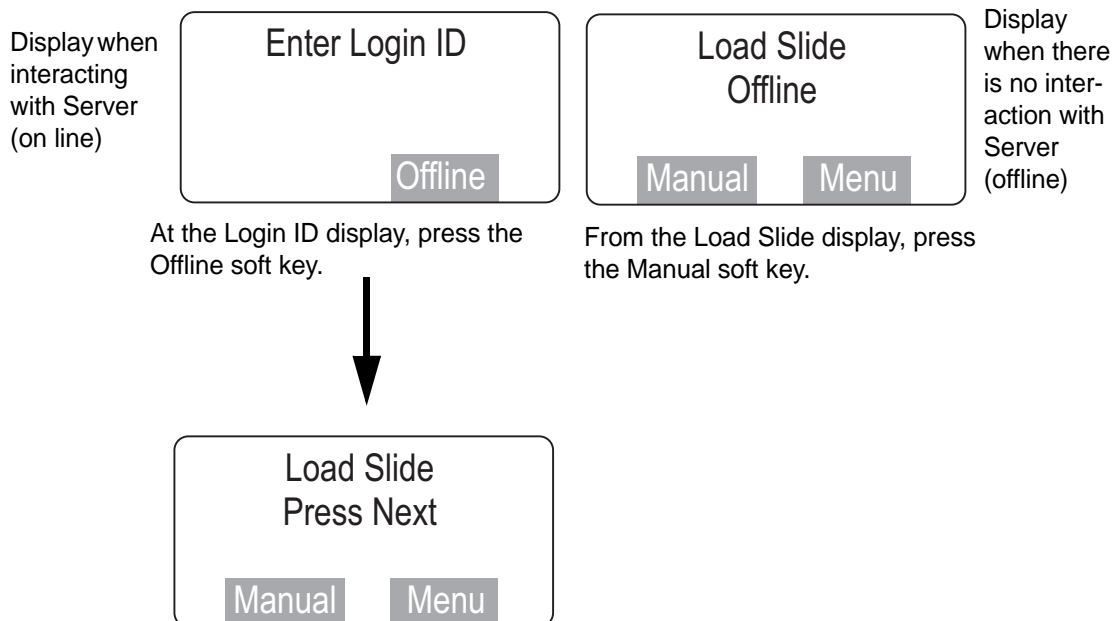
MANUAL SLIDE REVIEW

ThinPrep slides may be manually reviewed and marked at the Review Scope. Manual Review is always an available option. It will be required in certain conditions, which include:

- Slide not imaged (the slide has not been imaged by the Image Processor)
- “Slide Data Error” message (the slide was imaged but there is an error in the data that makes it unavailable for Auto Review)
- Slide rejected by the Image Processor during imaging (too dense, too scant, too many bubbles, etc.)
- No communication with the server is available
- Other problems such as a slide physical defect, incorrect labeling or incorrect coverslipping

Accessing Manual Review Mode

Manual Review mode may be accessed at Login display (via the menu) or at the start of a new slide review during Auto Review.



Press the **Offline** soft key when the Enter Login display appears (either at power up, or via the menu)

Or

MANUAL REVIEW (continued)

At the Load Slide display, press the **Manual** soft key.

Note: When working offline, all user preferences will be set to default values. Refer to Preferences, page 4.13, to temporarily set preferences for an offline screening session.

Load a slide onto the stage. (Refer to Figure 3-2.)

Register the Slide (Align Cell Spot)

Press the **Manual** soft key and the following screen will display.



Align Cell Spot
With Indicator
Press Next

Manual Review cannot make use of the fiducial marks that are printed on the ThinPrep[®] Microscope Slides. In order to create a reference coordinate for physically dotting the slide at the end of review, the operator must align two edges of the cell spot with the mark indicator.

Look through the eyepieces and using the joystick, move the cell spot up or down to align the **bottom edge** of the cell spot with the inner surface of the illuminated 'L' indicator mark. Only vertical movement is allowed on the joystick. (Refer to Figure 3-4, Align Cell Spot.)

Note: It is important to try to align along the **edge** of the cell spot, rather than at a group of cells that may be easily recognized later.

Press the **Next** button on the pod when satisfied with the first alignment.



Align Cell Spot
With Indicator
Press Next

Next, the second alignment is made. Look through the eyepieces and using the joystick, move the cell spot left or right to align the **left edge** of the cell spot with the inner surface of the illuminated 'L' indicator mark. Only horizontal movement is allowed on the joystick. (Refer to Figure 3-4, Align Cell Spot.)

3

OPERATION OF THE REVIEW SCOPE

MANUAL REVIEW (continued)

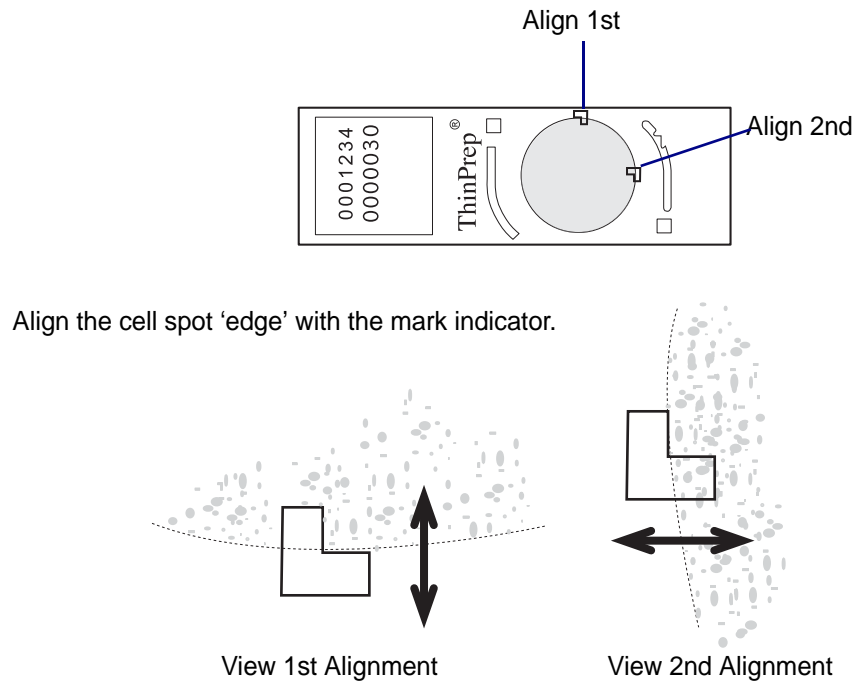
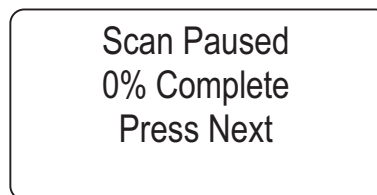


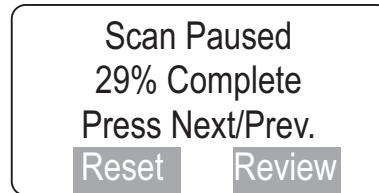
Figure 3-4 Align Cell Spot

Press the **Next** button on the pod when satisfied with the second alignment.

Manual Scan/Review of the Cell Spot



To proceed with the scan, press the **Next** button on the pod. The motorized stage will present the entire cell spot in a defined path at 10X magnification. The **Next** button on the pod must be pressed to advance the stage movement. The console display shows the progress of the cell spot scan in 1% increments.

MANUAL REVIEW (continued)

'Review' soft key appears the first time you electronically mark.

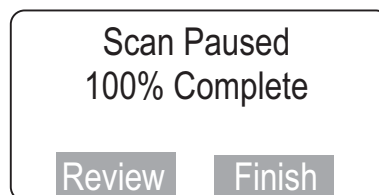
The operator may:

- Press the **Next** button on the pod to move to the next location
- Move the joystick to view a different area of the slide
- Press the **Object** button on the pod to change magnification
- Press the **Mark** button on the pod to electronically mark or unmark cells for physical marking

Note: Be sure to position the object so that the physical mark will not obscure it.

- Press the **Review** soft key to review electronic marks (electronic marks may be added or deleted)
- Press the **Reset** soft key to restart the scan at the beginning
- Press the **Prev** button on the pod to go back to the previous field of view

An audible beep indicates the completion of scanning. The display shows Scan Complete.

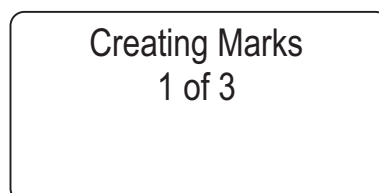


Press the **Review** soft key to review electronic marks.

Press the **Finish** soft key to finish manual slide review.

Physical Marking of the Slide

If any areas were electronically marked for physical marking, the pen dots the slide now. The number of marks count up until all marks are complete.

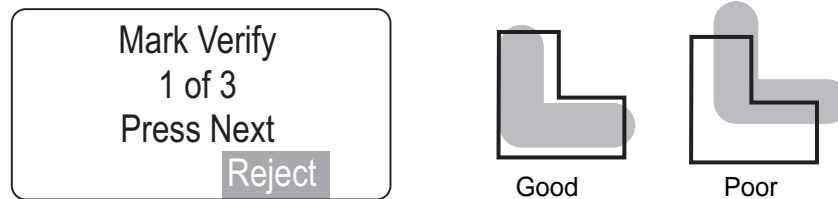


3

OPERATION OF THE REVIEW SCOPE

MANUAL REVIEW (continued)

When the physical marks have been made, they are presented for final approval. This is to ensure that the physical marks coincide with the electronic marks.



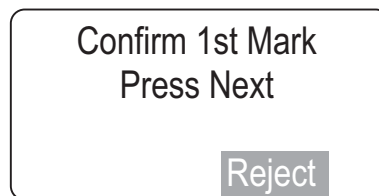
The pen mark should align within the illuminated 'L' shape of the Mark Indicator. If the physical marks are acceptable, press the **Next** button on the pod to continue.

If the marks are not acceptable, press the **Reject** soft key. The review of the slide is cancelled.

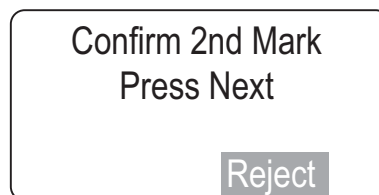
Note: If the marks are rejected, the slide may be reviewed again at the Review Scope (the entire process is repeated). The marks from the marking pen should be removed before viewing the slide again.

Check the Slide Registration

If all the marks have been accepted, the stage positions the slide exactly at the first cell spot alignment location. The slide registration is checked to confirm that there has been no slide movement or loss of stage position during slide review.



If the edge of the cell spot aligns with the illuminated mark indicator, press the **Next** button on the pod. The stage moves to the second cell spot edge position.



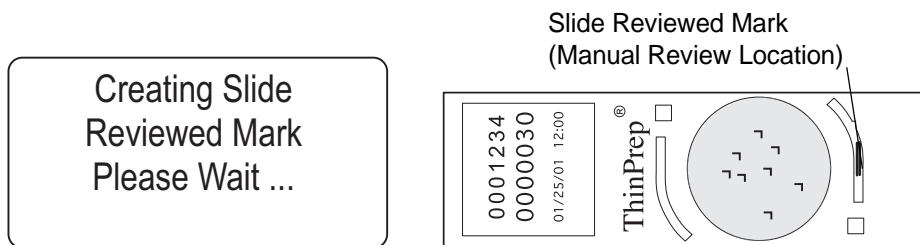
If the alignment is acceptable press the **Next** button.

If either of the positions do not align with the mark indicator, press the **Reject** soft key. The slide review will be cancelled. Any marks should be removed.

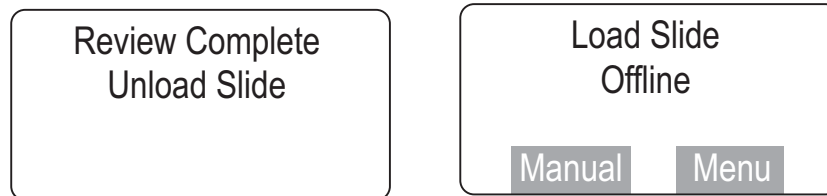
MANUAL REVIEW (continued)



When the cell spot alignment has been confirmed, the stage positions the slide to receive the Slide Reviewed Mark. The marker pen is uncapped and a small double line is marked on the coverslip, located on the bottom arc of the slide. This indicates that a slide has completed an entire manual review process.



An audible beep indicates the mark has been created. Slide review is complete and the slide may be unloaded from the slide holder. The display transitions to the "Load Slide" screen.



Another slide may be loaded for manual review.

3

OPERATION OF THE REVIEW SCOPE

SECTION F

SHUTTING DOWN THE REVIEW SCOPE

Normal Shut Down

When you are finished screening slides, the Review Scope may be shut off.

Make sure there are no slides left on the stage. Turn off the illuminator lamp switch. Turn off the Review Scope power switch. (Refer to Figure 3-5.)

The Review Scope may be covered with the dust cover provided with it.

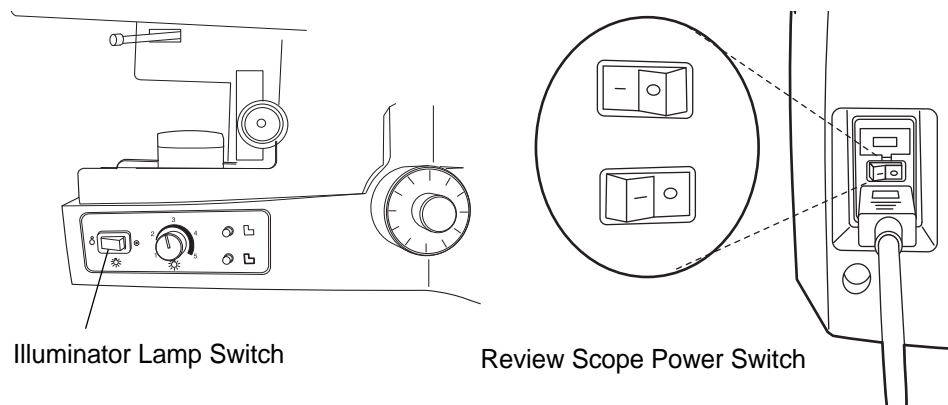


Figure 3-5 Review Scope Lamp Switch and Power Switch

Taking the Instrument Out of Service (Extended Shut Down)

If the Review Scope is to be removed from service, or shut down for an extended time, follow the steps for normal shut down and unplug the instrument.

Chapter Four

Operation of the Software Menu

SECTION**A****INTRODUCTION**

A User accessible software menu is available for calibration of the Review Scope components and to select user preferences. Refer to Figure 4-1, Review Scope On-line Menus. User input is via the keys on the console keypad and the joystick and buttons on the pod. The display on the console provides visual user interface. An audible beep function is also used to indicate completion of some software tasks.

User preferences for joystick button setup and movement speed, autoscan type, speed and direction, autolocate speed and audible beep volume may be selected, saved or changed. A preference setting profile is associated with each User Login ID and is retrieved from the Server at the time of Login. Regardless of which RS one logs onto, the last saved configuration will be enabled at the time of User Login. Preferences may be changed at any time. Factory default settings may be restored from this menu.

4

OPERATION OF THE SOFTWARE MENU

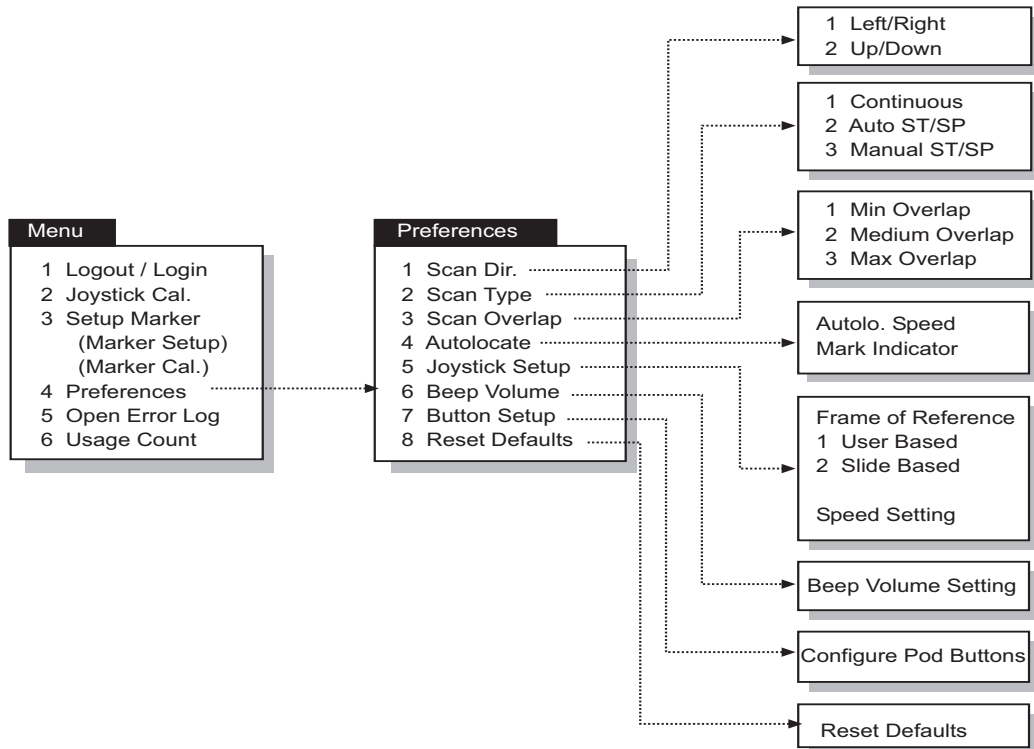
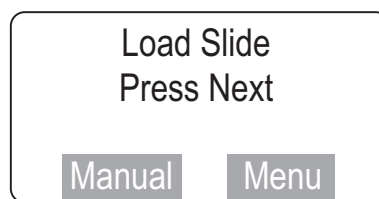
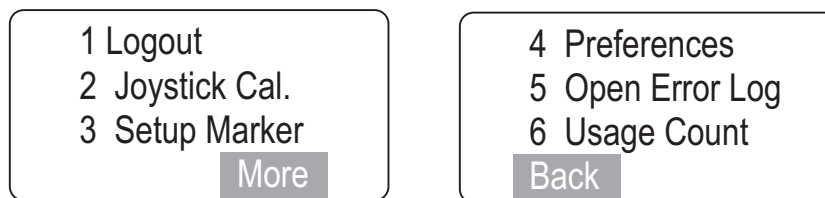


Figure 4-1 Review Scope On-line Menus

To access the menus, at the Load Slide display, press the **Menu** soft key on the console.



The menu list appears as two 'pages' of options, both of which are shown here.



To select an option, press the corresponding number key on the console keypad. Press the **More** or **Back** soft keys to move from page to page of the menu.

SECTION
B

MENU OPTION 1 LOGIN/LOGOUT

If the RS is offline (not communicating with the server), the menu option reads **Login**; if the RS is online, the menu option reads **Logout**.

Login is used to enter the three-digit operator ID at the start of a screening session at the review scope. As soon as the numbers are entered, the RS queries the server to confirm that the ID is valid. If any user preferences have been saved for that ID, they are immediately activated on the RS.

Note: The operator ID is setup via the User Interface at the Image Processor or server. Consult your lab manager or the Image Processor Operator's Manual to address any operator ID issues.

Logout is only available if user Login was successful and the Review Scope is actively connected to the Server.

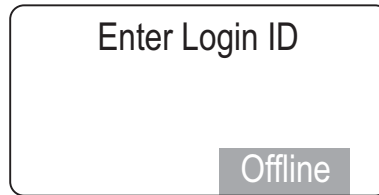
- Logout is used to log out of the current session at the Review Scope.
- Logout is used to save preferences associated with a user Login ID. If any preferences have been selected, they are not saved on the server until Logout has been performed.

The menu options must be visible on the console display to activate a particular selection. Press **1** on the key pad to logout.

A display prompting confirmation of user logout appears. Press the **Yes** soft key on the console if logout is desired.

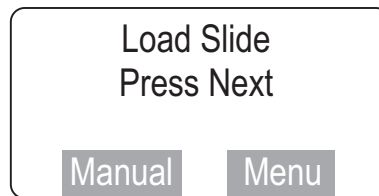
4

OPERATION OF THE SOFTWARE MENU



The Enter Login ID display will appear if logout was successful.

If the user does not wish to logout, press the **No** soft key on the console. The software will display the Load Slide screen.



SECTION C

MENU OPTION 2 JOYSTICK CALIBRATION

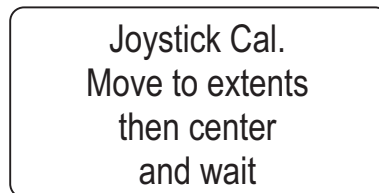
The joystick is calibrated by the operator via the system menu.

4-button pod: calibration is recommended once daily or at the start of each shift.

5-button pod: calibration is necessary upon installation of the pod, or if the pod has been removed and then reinstalled on a Review Scope.

Note: If drifting of the stage is noticed, calibrate the joystick.

To calibrate the joystick, from the menu select **2, Joystick Cal.**



The display prompts for the joystick to be moved so that it reaches its furthest point of travel in all directions. This is necessary for calculating the calibration. To calibrate the joystick:

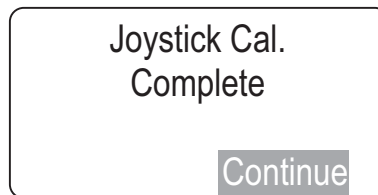
1. Place your finger in the center of the joystick. Deflect the button outward to the farthest possible extent.

2. While maintaining full deflection, roll your finger in a circle 2 or 3 times to move the joystick in the widest possible circles.
3. Return the joystick to the center and let go.
4. Do not touch the joystick while calibration calculations are being performed.

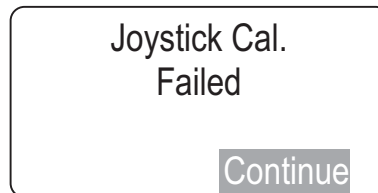


Figure 4-2 Calibrate the Joystick

In a few seconds, the calibration is complete. An audible beep will sound and the display indicates the calibration is complete.



Press the **Continue** soft key on the key pad to return to the Load Slide screen.



If calibration fails, retry it several times. If calibration continues to fail, contact Hologic Technical Support.

4

OPERATION OF THE SOFTWARE MENU

SECTION D

MENU OPTION 3 SETUP MARKER

Two object marker adjustments are available in this menu: Marker Setup, which adjusts the proximity of the pen tip to the slide for marking, and Marker Calibration, which calibrates the marker.

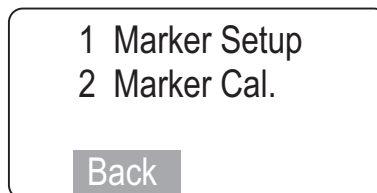
Marker Setup

Marker Setup adjusts the pen tip nearer to or further from the microscope slide when the pen is lowered for marking. Indications that adjustment is needed include:

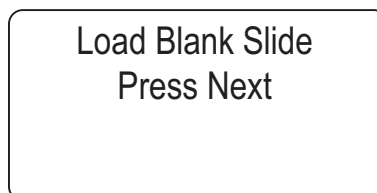
- The pen mark is too wide (too close to the slide)
- The pen drags on the slide between marks (too close to the slide)
- Scant or no mark on the slide (too far from the slide)

Before changing the Marker Setup, confirm the pen is seated correctly in the holder. Do a Marker Calibration.

From the menu, select **1, Marker Setup**.



A prompt to load a blank slide appears.



Load a blank ThinPrep slide into the slide holder on the stage. Press the **Next** button on the pod.

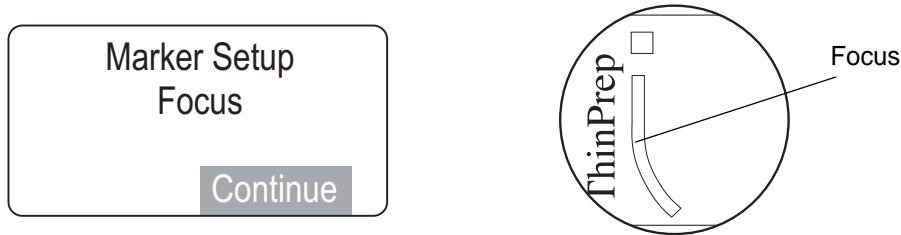
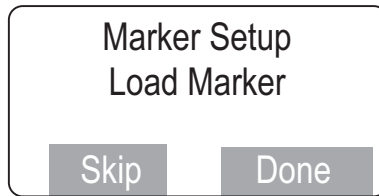


Figure 4-3 Focus on the Painted Arc

Looking through the eyepieces, focus the microscope on the top arc of the frosted area. (Refer to Figure 4-3.) Press the **Continue** soft key when ready.

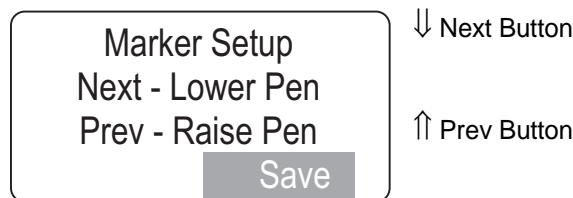


If a marking pen is already in the object marker holder, press the **Skip** soft key.

If there is no pen present or you are replacing a pen, take a new pen, uncap it and prime the marker by gently dragging the tip across a piece of lint free tissue. Load the pen into the holder.

- For ThinPrep Review Scopes that use the Sharpie marking pen, push the pen into the guide, making sure it is seated against the holder. Then press the locking arm to the right until it firmly grips the pen.
- For ThinPrep Review Scopes that use the Pilot marking pen, push the pen into the guide. Loosen your hold on the pen and notice that it moves up slightly. Gently hold the pen there and press the locking arm to the right until it firmly grips the pen. Because the pen is thinner than the holder, it may be helpful to hold the pen at a 15° angle (approximately the 1 o'clock position on a clock face) in the guide, while pressing the locking arm.

Press the **Done** softkey. (Refer to Figure 4-5.)



Press the **Next** or **Prev** buttons on the pod to step the pen closer to or away from the slide surface. Observe the movement of the pen as either button is repeatedly pressed.



OPERATION OF THE SOFTWARE MENU

If the pen is too close to the slide (leaving wide marks or bent pen tip), click on the **Prev** button to move the pen away from the slide. If the pen is not close enough to the slide, click on the **Next** button to bring the pen tip closer to the slide.

Click on **Save** to save the position.

WARNING: Glass
Moving Parts

Marker Calibration

Calibration of the pen used for physically marking the slide positions the pen so that the ink mark is within the 'L' shape of the mark indicator. Minimally, calibration should be performed:

- Daily
- Every time a new marker is installed
- After a mark is rejected while verifying marks

Note: The object marker on ThinPrep Review Scope model numbers 70575-001, 70575-003, 71062-001, and 71062-002 uses an ultra fine tip Sharpie® marking pen. The object marker on ThinPrep Review Scope model numbers 70669-001, 70669-002, and 70669-003 uses a Pilot extra fine marking pen. These pens are widely used for marking slides.

Note: If using a 4-button pod, joystick calibration should be done before marker calibration.

To calibrate the object marker, the Review Scope must be powered On. The lamp illuminator should be on and the white mark indicator lamp intensity should be turned up to a brightness for normal viewing.

From the menu, select option **3, Setup Marker**, and then select option **2, Marker Cal.**



Load a blank ThinPrep® microscope slide into the slide holder on the stage. Press the **Next** button on the pod.

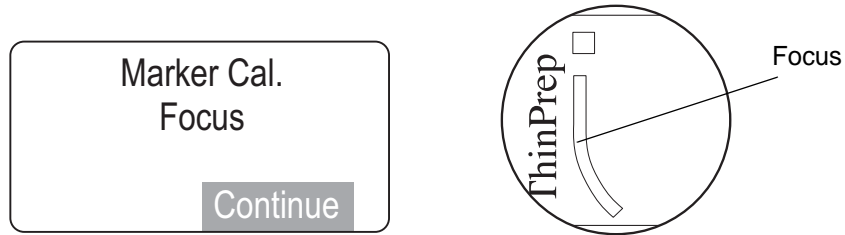
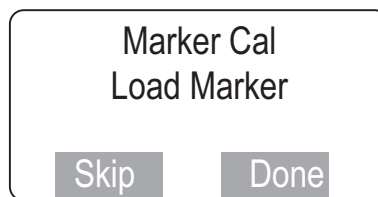


Figure 4-4 Focus on the Painted Arc

Looking through the eyepieces, focus the microscope on the top arc of the frosted area. (Refer to Figure 4-4.) Press the **Continue** soft key when ready.



If you are doing the routine calibration of the marker and a marking pen is already in the object marker holder, press the **Skip** soft key.

If you are replacing the pen with a new one, remove the pen now.

CAUTION: Do not load the Sharpie marking pen until prompted to do so. During loading, the control arm moves it to a position that allows for the best access, and ensures that it seats most securely against the seal diaphragm.

Take a new pen, uncap it and prime the marker by gently dragging the tip across a piece of lint free tissue. Load the pen into the holder.

- For ThinPrep Review Scopes that use the Sharpie marking pen, push the pen into the guide, making sure it is seated against the holder. Then press the locking arm to the right until it firmly grips the pen. (Refer to Figure 4-5.)

4

OPERATION OF THE SOFTWARE MENU

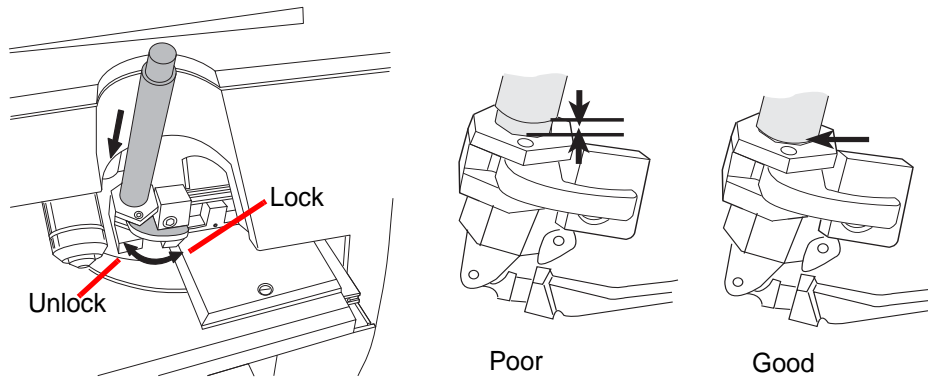


Figure 4-5 Load the Sharpie® Object Marker Pen

- For ThinPrep Review Scopes that use the Pilot marking pen, push the pen into the guide. Loosen your hold on the pen and notice that it moves up slightly. Gently hold the pen there and press the locking arm to the right until it firmly grips the pen. Because the pen is thinner than the holder, it may be helpful to hold the pen at a 15° angle (approximately the 1 o'clock position on a clock face) in the guide, while pressing the locking arm.

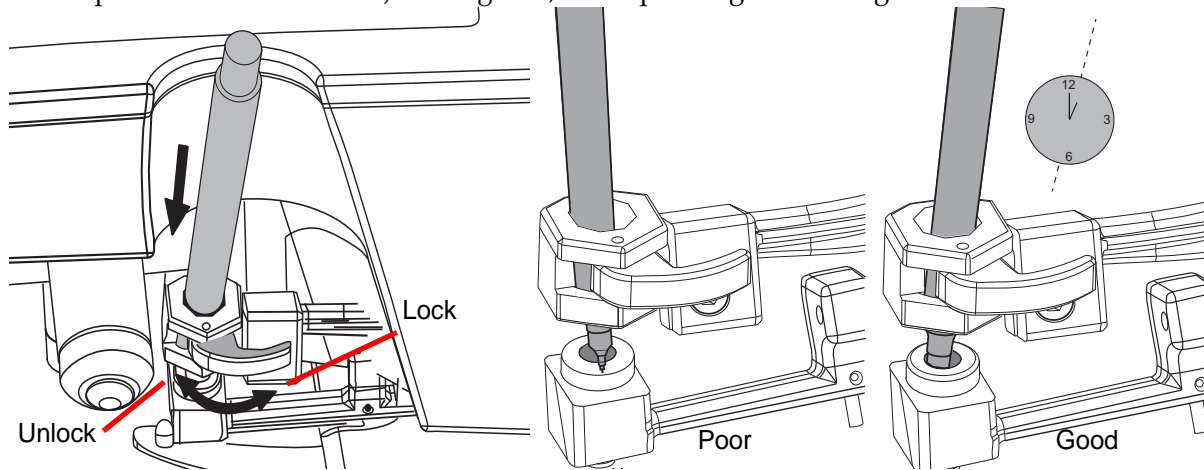


Figure 4-6 Load the Pilot Object Marker Pen

Press the **Done** soft key when the pen is loaded. A test mark will be made on the slide.

Creating Mark
Please Wait...

Center Mark
Press Next

The software prompts the user to center the mark in the illuminated mark indicator. Using the joystick, move the mark until it aligns within the boundaries of the 'L' shape of the mark indicator. (Refer to Figure 4-7.)

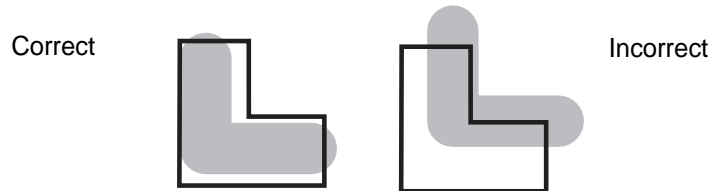


Figure 4-7 Align the Pen Mark Within the Mark Indicator

Press the **Next** button on the pod when ready.

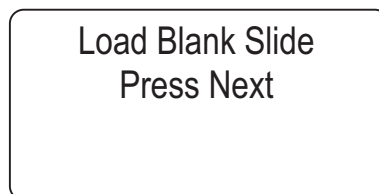


An audible beep indicates the marker calibration is complete. Press the **Continue** soft key to return to the Load Slide display. Unload the slide from the slide holder.

Prime the Object Marker

For Review Scopes that use the Pilot pen as the object marker, priming the pen may improve the flow of ink to the slide. Prime the pen after the marker has been set up and after the marker has been calibrated. Use the first several steps of the Marker Calibration process to uncap the marker.

From the menu, select option **3, Setup Marker**, and then select option **2, Marker Cal.**



Load a blank ThinPrep[®] microscope slide into the slide holder on the stage. Press the **Next** button on the pod.

4

OPERATION OF THE SOFTWARE MENU

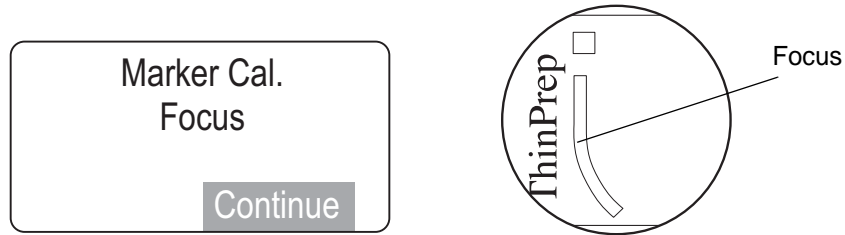


Figure 4-8 Focus on the Painted Arc

Looking through the eyepieces, focus the microscope on the top arc of the frosted area. (Refer to Figure 4-8.) Press the **Continue** soft key when ready.

Slide a lint-free wipe between the pen tip and the slide

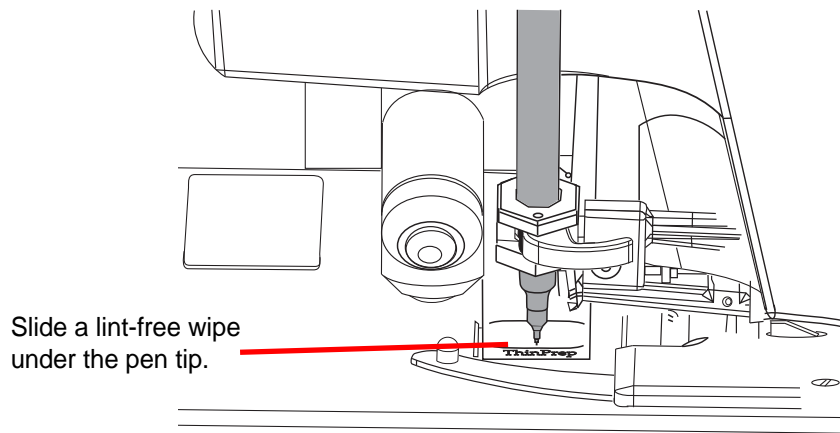


Figure 4-9 Prime the pen

Lift up the lint-free wipe so that it touches the pen top. When ink from the pen starts to flow freely to the lint-free wipe, the pen is primed and ready to use.

Press the cancel key \otimes to omit the remaining steps in the Marker Calibration process and return to the Load Slide display. Remove and discard the lint-free wipe.

Note: Alternatively, you can prime the Pilot marking pen by hand. Remove the pen from the holder, and press the pen against a lint-free wipe. In this case, the Marker Setup and Marker Calibration processes must be done after the pen is primed.

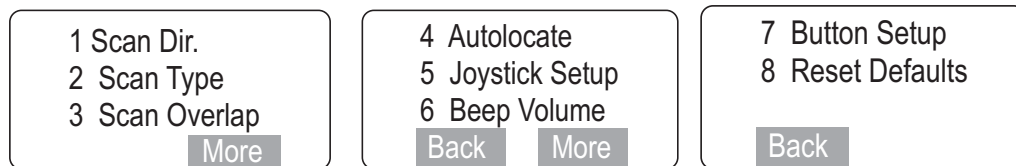
SECTION
E

MENU OPTION 4 PREFERENCES

Preferences allows the setting of user preferences including Autoscan settings and maximum speed for Autolocate. For each user-selectable preference, the console display shows the current setting of the parameter. Use the pod buttons to change the setting to the desired value. The setting is stored locally (in RS memory) until the user preferences are updated on the Server during user Logout.

Note: Preferences are not saved until Logout. At the next Login, the preferences for that User ID will be uploaded.

From the main menu, select option **4, Preferences**. All three 'pages' of the menu are shown below. To select an option, press the corresponding number key on the console keypad. Press the **More** or **Back** soft keys to move from page to page of the menu.



Note: Refer to the preferences worksheet at the end of this chapter, when evaluating and recording preference settings.

Preferences 1 Scan Direction

The direction of the stage movement during autoscan can be selected. From the preferences menu, select **1, Scan Dir.** The direction options are Left/Right or Up/Down. Press the cancel key ⊗ at any time to exit out of menus.



On the console keypad press the number key corresponding to your choice. The selected direction will have a highlighted box around it. Press the **Save** soft key to save that preference. The scan direction setting will now be used during this login session and will be saved to the user preferences profile at logout.



OPERATION OF THE SOFTWARE MENU

Preferences 2 Scan Type

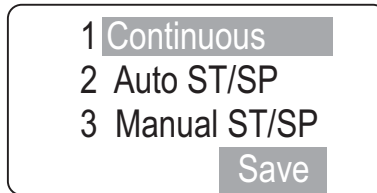
The autoscan function presents the entire cell spot in a defined path at 10X magnification. Three types of scan motion are selectable:

- **Automatic Continuous** - Scan motion is initiated by the RS and consists of steady movement across the cellular region, with each pass overlapping the previous scan. The user may speed up or slow down the movement by moving the joystick to the *right* for a faster scan and to the *left* for a slower scan. Scan motion may be paused and resumed (from where the scan was interrupted) by pressing the **Next** button on the pod.
- **Automatic Start Stop** - Scan motion is initiated by the RS and consists of a series of discrete, overlapping fields of view, including a pause at each view. The user may increase or decrease the duration of each pause by moving the joystick to the *right* for a faster scan and to the *left* for a slower scan. Scan motion may be paused and resumed (from where the scan was interrupted) by pressing the **Next** button on the pod.
- **Manual Start Stop** - Using the **Next** button on the pod, the user initiates the scan motion, which is a series of discrete, overlapping fields of view (identical to the Auto Start-Stop pattern). The autoscan is paused after each field of view and remains there until the user presses the **Next** button again.

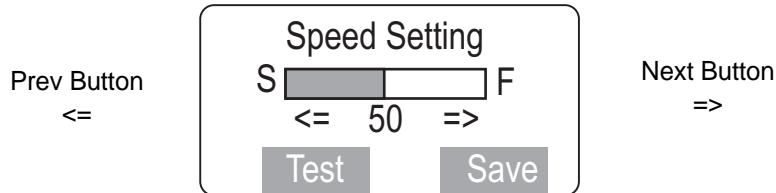
To set the preferred scan type, select option **2, Scan Type**.

Note: In order to have a visual reference during the speed and direction test functions, load a test slide in the stage slide holder prior to selecting the preferences. If a slide is not present, the display will prompt you to load one.

Continuous Scan

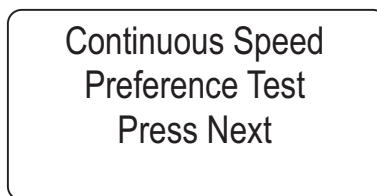


A list of the scan motion options is displayed. To select **Continuous Scan**, press **1** on the console keypad and then press the **Save** soft key. For this preference, a scan speed setting will be adjusted and saved. Press the cancel key ⊗ at any time to exit out of menus.



A speed setting display shows a highlighted bar with the current speed setting (default is 50). Press the **Next** button on the pod to increase the speed value. Press the **Prev** button on the pod to decrease the speed value.

When the speed has been changed, select the **Test** soft key on the console to view the speed of the scan motion.



A Continuous Speed Preference Test display appears. The stage begins to move at the speed of the new setting. Look through the eyepieces to observe the speed.

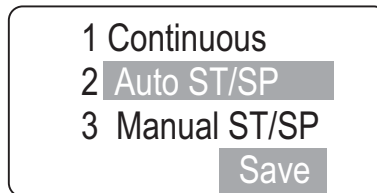
Press the **Next** button on the pod to return to the speed setting page. To adjust the speed setting, use the **Next** and **Prev** buttons on the pod.

To save this setting, press the **Save** soft key on the speed setting display. The software returns to the Preferences menu. The continuous speed setting will now be used during this login session and will be saved to the user preferences profile at logout.

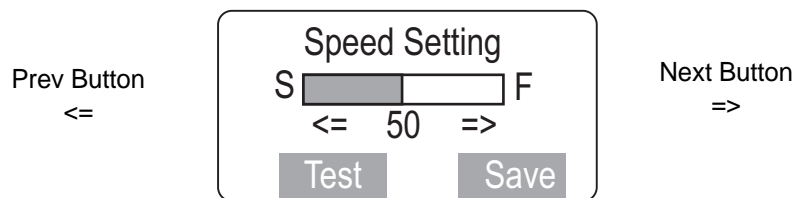


OPERATION OF THE SOFTWARE MENU

Auto Start-Stop Scan

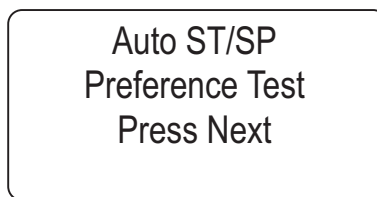


To select **Auto Start-Stop Scan**, press **2** on the console keypad and then press the **Save** soft key. For this preference, a scan speed setting (the speed of the stage moving from field of view to field of view) and the pause duration will be adjusted and saved. Press the cancel key ⊗ at any time to exit out of menus.



A speed setting display shows a highlighted bar with the current speed setting (default is 50). Press the **Next** button on the pod to increase the speed value. Press the **Prev** button on the pod to decrease the speed value.

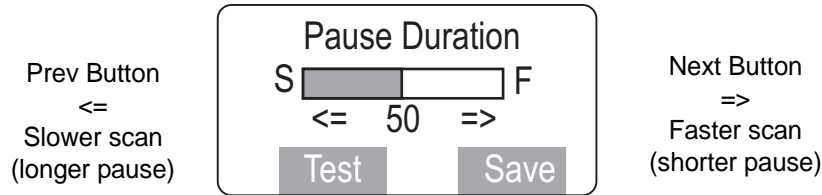
When the speed has been changed, select the **Test** soft key on the console to view the speed of the stage motion between fields of view.



The Auto Start-Stop Preference Test display appears. The stage begins to move at the speed of the new setting. Look through the eyepieces to observe the speed.

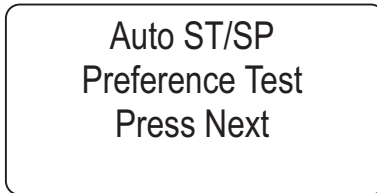
Press the **Next** button on the pod to return to the Speed Setting display. If the speed setting needs adjustment, repeat adjusting the speed and testing it until achieving the desired results.

When the scan speed is acceptable, press the **Save** soft key. The display then changes to the Pause Duration setup screen.



Similar to the speed setting display, use the **Next** button on the pod to decrease the length of the pause and use the **Prev** button to increase the length of the pause.

When the pause duration has been changed, select the **Test** soft key on the console to view the scan with the new pause duration.



The Auto Start-Stop Preference Test display appears. Look through the eyepieces to observe how long the pauses last. Press the **Next** button on the pod to return to the Pause Duration setup display.

If the setting is not as desired, press the **Next** or **Prev** buttons on the pod to adjust the pause duration. Continue adjusting the pause length and testing it until achieving the desired results.

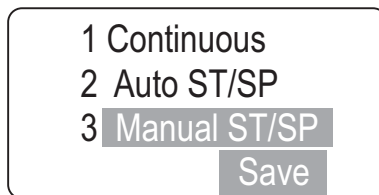
When the pause length is acceptable, press the **Save** soft key to save the setting. The auto start-stop and speed settings will now be used during this login session and will be saved to the user preferences profile at logout.

Note: This is the nominal value for Auto Start/Stop and it can be dynamically varied during auto-scan by moving the joystick to the *right* for a faster scan and to the *left* for a slower scan.



OPERATION OF THE SOFTWARE MENU

Manual Start-Stop Scan



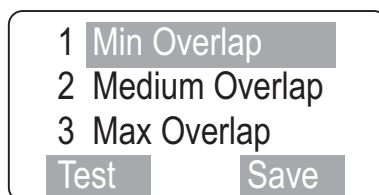
To select **Manual Start-Stop Scan**, press **3** on the console keypad. For this preference, there are no settings to adjust, as starting and stopping of the scan is manual, by pressing the **Next** button on the pod. The speed of the scan between fields of view is the Auto Start/Stop speed setting. Press the **Save** soft key to save Manual Start-Stop as the scan preference type. The manual start-stop scan setting will now be used during this login session and will be saved to the user preferences profile at logout.

Note: If the speed is too fast or too slow, change it by changing the speed setting in Auto ST/SP.

Note: Refer to the preferences worksheet at the end of this chapter, when evaluating and recording preference settings.

Preferences 3 Scan Overlap

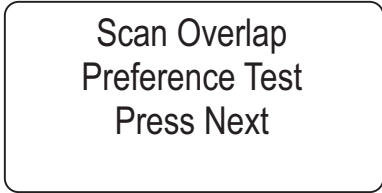
The Scan Overlap preference setting selects how much the field of view overlaps from row to row when the review scope scans the cell spot during slide review. In the Preferences menu, select **3, Scan Overlap**.



Select the scan overlap:

- minimum
- medium
- maximum

To view the overlap, place a slide on the stage (for visual reference) and click the **Test** soft key.



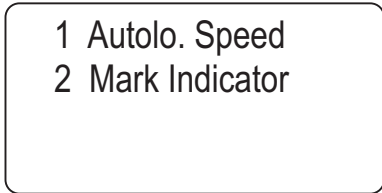
Look through the eyepieces to observe the field of view overlap as the cell spot is scanned. Press the **Next** button on the pod to return to the Scan Overlap menu.

Select a different overlap setting if desired, or press the **Save** soft key to save the setting.

Note: Refer to the preferences worksheet at the end of this chapter, when evaluating and recording preference settings.

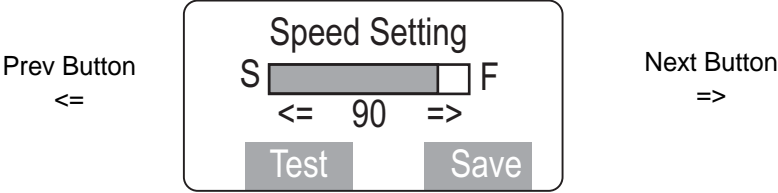
Preferences 4 Autolocate

Autolocate options adjust the speed of movement from field to field and the presence of the white Mark Indicator during autolocate. (The mark is on or off.)



Autolocate speed

The autolocate speed preference adjusts how quickly the stage accelerates and decelerates when moving between the 22 fields of interest identified by the Image Processor. For this preference, a speed setting will be adjusted and saved. From the Autolocate preferences menu, select **1, Autolo. Speed**. Press the cancel key ⊗ at any time to exit out of menus.



A speed setting display shows a highlighted bar with the current speed setting (default is 90). Press the **Next** button on the pod to increase the speed value. Press the **Prev** button on the pod to decrease the speed value.

When the speed has been changed, select the **Test** soft key on the console to view the speed of the autolocate motion.



OPERATION OF THE SOFTWARE MENU



An Autolocate Test display appears. Look through the eyepieces and repeatedly press the **Next** button on the pod to observe the speed of the stage motion. Press the **Finish** soft key return to the autolocate speed setting display.

To adjust the speed setting, press the **Next** and **Prev** buttons on the pod to increase or decrease the speed setting. Press the **Test** soft key. Repeat this process until the setting is as desired.

To save this setting, press the **Save** soft key. The autolocate speed setting will now be used during this login session and will be saved to the user preferences profile at logout.

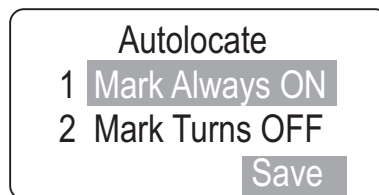
Mark Indicator On/Off

The white mark indicator may be turned off during autolocate.

If it is preferred that the mark indicator always be visible during slide review, select **Mark Always ON**. Press **1** on the keypad and then press the **Save** softkey.

If it is preferred that the mark indicator is not visible during slide review, select **Mark Turns OFF**. Press **2** on the keypad and then press the **Save** softkey. The white mark indicator will remain off until the operator moves the joystick, or presses the Mark button.

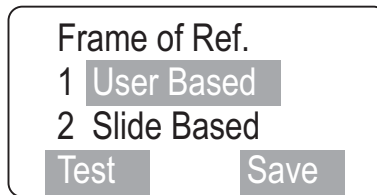
Note: the green mark indicator is unaffected by the preference setting.



Note: Refer to the preferences worksheet at the end of this chapter, when evaluating and recording preference settings.

Preferences 5 Joystick Setup

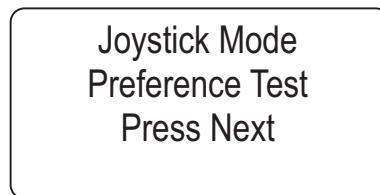
The joystick setup selects the frame of reference on which the slide movement is based and then sets the speed of movement. From the preferences menu, select **5, Joystick Setup**. Press the cancel key ⊗ at any time to exit out of menus.



The frame of reference orients the perceived direction of the slide movement when the joystick is manipulated.

- **User based** frame of reference is like typical microscope movement - if the joystick is moved upward, the cells appear to move downward.
- **Slide based** frame of reference means the cells appear to move in the same direction as the direction of the joystick movement. (Moving the joystick upward will cause the cells to appear to move upward.)

Press the number key on the console keypad that corresponds with your choice. The selected direction will have a highlighted box around it. Press the **Test** soft key to view the orientation of the slide movement when the joystick is moved.



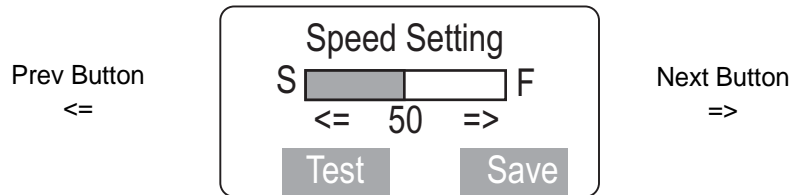
The joystick orientation preference test display appears. Look through the eyepieces and view the response of the slide when the joystick is moved around. Press the **Next** button on the pod to return to the frame of reference setup display.

Press the **Save** soft key to save that preference.

Next the Joystick Speed Setting display appears.

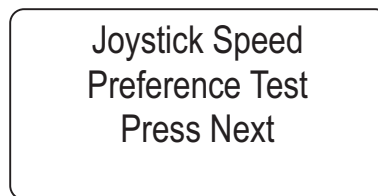
4

OPERATION OF THE SOFTWARE MENU



The speed setting display shows a highlighted bar with the current speed setting (default is 50). Press the **Next** button on the pod to increase the speed value. Press the **Prev** button on the pod to decrease the speed value.

When the speed has been changed, select the **Test** soft key on the console to view the motion when the joystick is moved.



The joystick Speed Preference Test display appears. Look through the eyepieces and use the joystick to move around the slide. Press the **Next** button on the pod to return to the speed setting display.

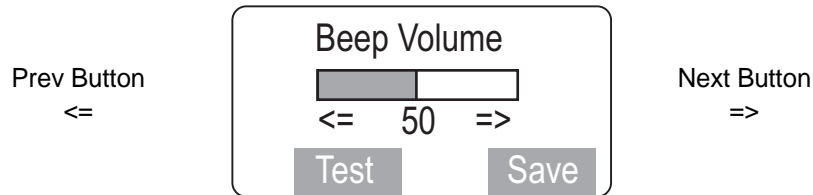
To adjust the speed setting, press the **Next/Prev** buttons on the pod. Press the **Test** key as needed. Repeat this process until the setting is as desired.

To save this setting, press the **Save** soft key. The frame of reference and joystick speed settings will now be used during this session and will be saved to the user preferences profile at logout.

Note: Refer to the preferences worksheet at the end of this chapter, when evaluating and recording preference settings.

Preferences 6 Beep Volume

The volume of the audible beep may be increased or decreased. From the preferences menu, select **6, Beep Volume**. Press the cancel key ⊗ at any time to exit out of menus.



The Beep Volume display shows a highlighted bar with the current volume setting. Press the **Next** button on the pod to increase the volume. Press the **Prev** button on the pod to decrease the volume.

Press the **Test** soft key to create a test beep. Two beeps will be heard in close succession. The first beep is at the old setting. The second beep is at the new setting.

Press the **Save** soft key to save the volume setting.

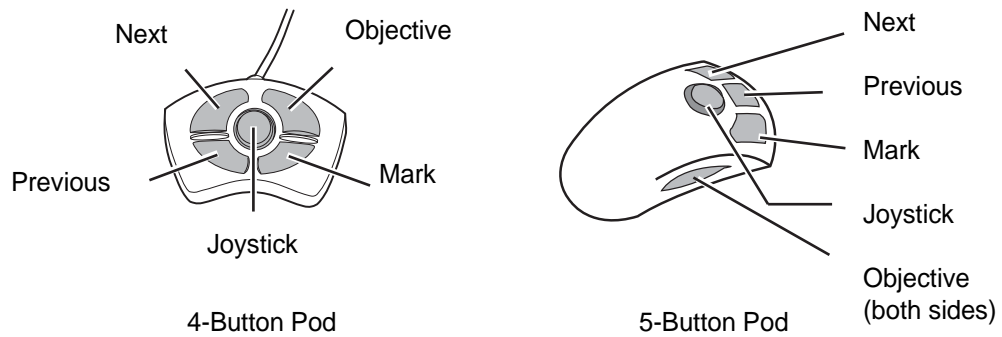
Note: Refer to the preferences worksheet at the end of this chapter, when evaluating and recording preference settings.

4

OPERATION OF THE SOFTWARE MENU

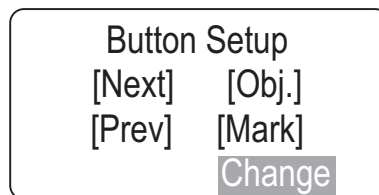
Preferences 7 Button Setup

The function buttons on the pod may be reassigned to fit user preference. From the preference menu, select 7, **Button Setup**. Press the cancel key ⊗ at any time to exit out of menus. Refer to Figure 4-10 for defaults.

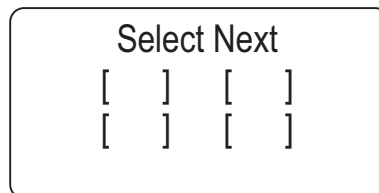


Note: Only one pod is used

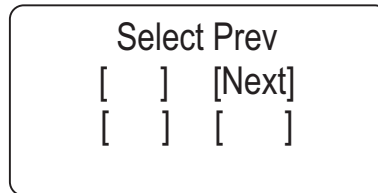
Figure 4-10 Pod Button Defaults



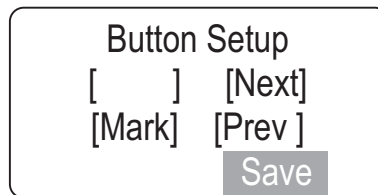
The button setup display shows the current orientation of button functions. To reconfigure the setting, press the **Change** soft key on the key pad. The pod buttons will be reconfigured in this order: Next, Previous, Objective, Mark.



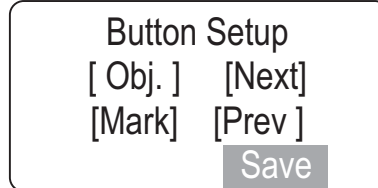
The pod button locations are represented by empty brackets. The display prompts to press the button the you would prefer to act as the **Next** button on the pod. Press the *actual button* on the pod that will be assigned as the **Next** button. (The configuration in the following displays are for example, only.)



The **Next** button position is shown on the display. Select the location for the **Previous** button. Press the *actual button* on the pod that will be assigned as the **Previous** button.



The **Next** and **Previous** button position are shown on the display. Select the location for the **Mark** button. Press the actual button on the pod that will be assigned as the **Mark** button.



As soon as the **Mark** button is located, the **Objective** button position is automatically filled in the remaining empty location.

Press the **Save** soft key on the key pad to save the new configuration.

Note: Refer to the preferences worksheet at the end of this chapter, when evaluating and recording preference settings.

4

OPERATION OF THE SOFTWARE MENU

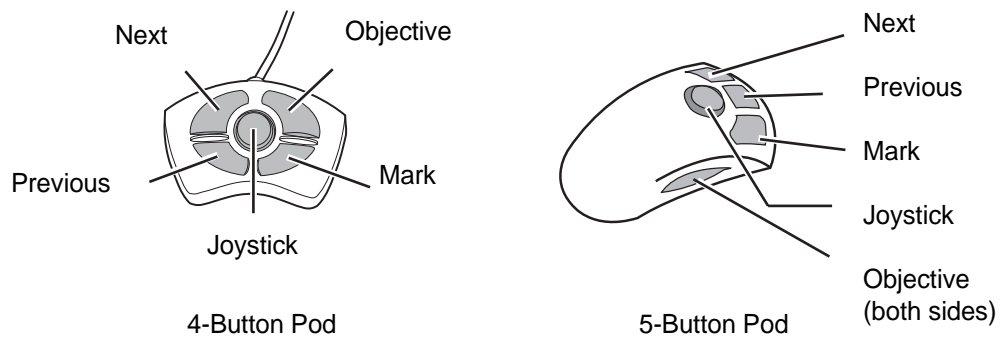
Preferences 8 Reset Defaults

Preferences associated with the active user ID may be restored to the factory default settings, if desired. All settings will return to the default configuration.

From the preferences menu, select **8, Reset Defaults**.

The default values for the parameters that may change are restored. The default values are:

- Left/Right scan direction
- Auto Start-Stop, scan speed at 50
- Pause duration at 50
- Autoscan Overlap at minimum
- Autolocate speed at 90
- Mark Indicator always ON
- User based frame of reference, speed at 50
- Beep volume at 50
- Pod button arrangement



Note: Only one pod is used

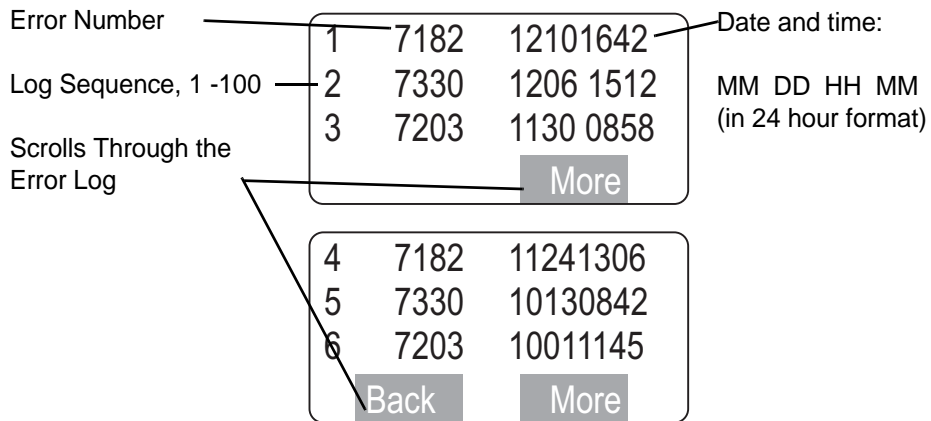
Figure 4-11 Pod Button Defaults

SECTION
F

MENU OPTION 5 OPEN ERROR LOG

The Review Scope logs the last 100 errors encountered, beginning with the most recent. This display allows the user to view and scroll through the list of errors. Displayed are the log sequence, the error number, the date and time the error was logged.

To view the error log, from the menu select **5, Open Error Log**.



Use the **More** and **Back** soft keys to scroll through the log. To exit the log, press the **Cancel** soft key.



OPERATION OF THE SOFTWARE MENU



MENU OPTION 6 USAGE COUNT

The Review Scope counts the number of slide reviews performed on each microscope. The Usage Count display shows the number of reviews.

From the menu, select **6, Usage Count**.



To close the display, press the **Continue** soft key.

ThinPrep[®] Review Scope Preferences

Name: _____

Date: _____

1 Scan Direction

Left to Right
Up and Down

2 Scan Type

Continuous
Speed _____
Auto Start/Stop
Speed _____
Pause _____
Manual Start/Stop

Trial #1	Trial #2	Trial #3	Final Setting

Speed: Speed between FOV
Pause: How long you want to look at the cells

3 Scan Overlap

Minimum Overlap
Medium Overlap
Maximum Overlap

Trial #1	Trial #2	Trial #3	Final Setting

4 Autolocate

Speed _____

Trial #1	Trial #2	Trial #3	Final Setting

Mark Indicator

Always ON	Mark Turns OFF	Final Setting

White mark indicator is always ON during autolocate & autoscan OR
The mark indicator turns OFF during autolocate & autoscan unless the joystick is used, or the Mark button is pressed

5 Joystick Setup

Frame of Reference
User Based

(frame of reference is like typical microscope movement – the joystick is moved upward, the cells appear to move downward)

Slide Based

(the cells appear to move in the same direction as the joystick direction – moving the joystick upward will cause the cells to appear to move upward)

Joystick Speed _____ (how fast do you want the stage to move when using the joystick)

6 Beep Volume

Trial #1	Trial #2	Trial #3	Final Setting

7 Button Setup

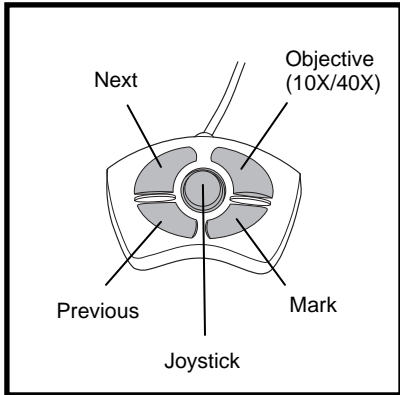
The function buttons on the Navigator pod may be reassigned to fit user preference
(See the following page for diagrams)

8 Reset Defaults

Note: Returns all preferences to default levels.

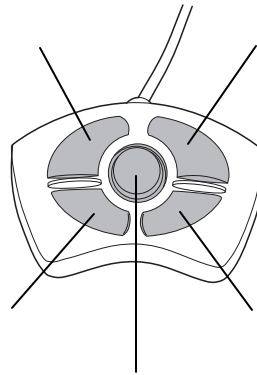
This page is for photocopy purposes

Button Setup on the Navigator Pod

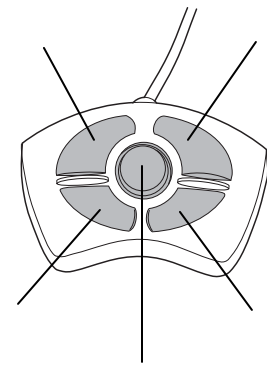


Default Settings

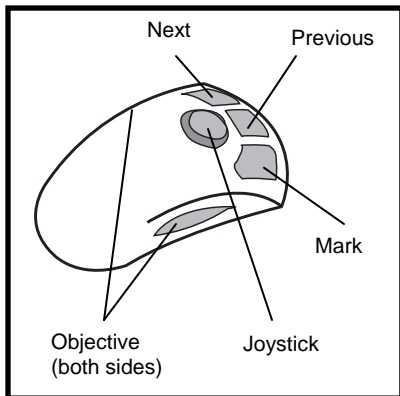
N = Next
 P = Previous
 M = Mark
 O = Objective



Joystick
Trial Settings

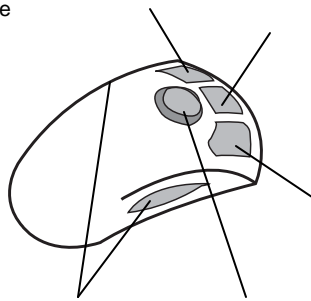


Joystick
Final Settings

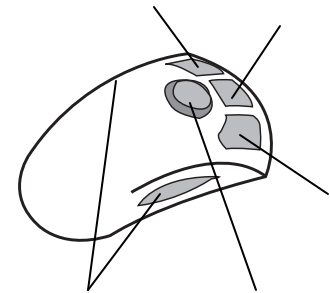


Default Settings

N = Next
 P = Previous
 M = Mark
 O = Objective



Joystick
Trial Settings



Joystick
Final Settings

Chapter Five

Review Scope Maintenance

The instrument must be maintained regularly in order to ensure reliable performance. Perform maintenance on the instrument as described in this section. The instrument requires supplemental preventive maintenance annually by Hologic service personnel.

**SECTION
A****DAILY****JOYSTICK CALIBRATION**

4-button pod: calibration is recommended once daily or at the start of each shift.

5-button pod: calibration is necessary upon installation of the pod, or if the pod has been removed and then reinstalled on a Review Scope.

Refer to the calibration instructions on page 4.4.

MARKER CALIBRATION

The marking pen arm should be calibrated once a day. It should also be calibrated any time the pen is replaced. Refer to the complete instructions on calibrating and loading the marker on page 4.8

Note: ALWAYS load the marking pen using the Marker Calibration function. The automatic stage movement will position the pen arm in the correct position to receive the pen.

**SECTION
B****GENERAL CLEANING**

CAUTION: Do not use strong solvents on painted or plastic surfaces.

Wipe down the exterior housing of the microscope monthly or as needed with a lint-free wipe dampened with water.

When not using the microscope, keep it covered with the provided dust cover.

Clean the eye pieces and lenses as necessary with lens paper.

Using a cotton or foam tipped swab, clean the “slide present sensor,” the slide registration edges and the top surface of the stage with xylene or a suitable solvent that will remove mounting medium. (Do

5

REVIEW SCOPE MAINTENANCE

not drip the cleaning agent on painted surfaces or plastic.) Remove any glass dust from these areas. (Refer to Figure 5-1.)

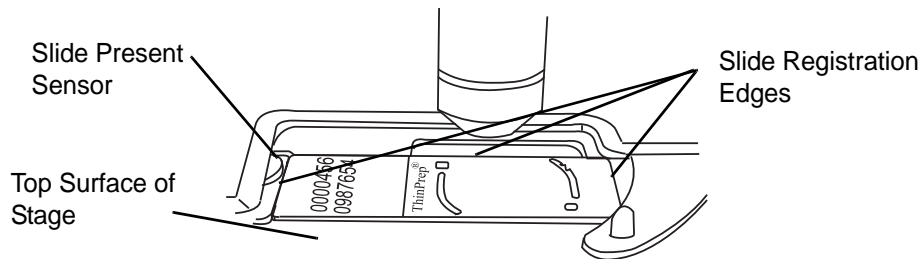


Figure 5-1 Slide Present Sensor

SECTION C

REPLACING THE ILLUMINATOR LIGHT BULB

Refer to Ordering Information for replacement light bulbs.

The microscope illuminator uses a halogen light bulb to light the optical field. The light bulb is located beneath the collector lens and is accessed through the bottom of the microscope. A Phillips Head screwdriver is required. Use gloves or gauze to protect the halogen light bulb from skin oils.

WARNING: Hot Surfaces

Glass

1. Turn the microscope off, if it is already on. Wait a few minutes for the lamp area of the microscope to cool.
2. Unplug the power cord and communication cables on the rear of the microscope. (Refer to Figure 5-2.)
3. The scope must be on its back to access the illuminator. Remove and set aside any loose objects that may be disturbed by moving the scope, such as the eye pieces, the collector filters (if present), and/or slides.

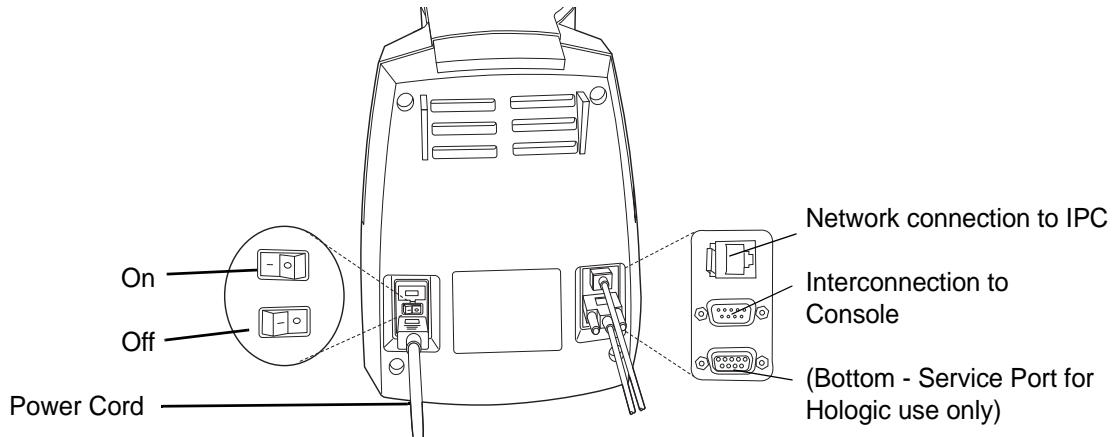


Figure 5-2 Rear of Microscope

CAUTION: Do not grasp the microscope by the stage or the optics. Do not rest the stage against your body as this may misalign the stage.

- Grasping the scope by the bottom of the housing, gently tilt the microscope over onto its back cover. (Refer to Figure 5-3.) A soft material, (such as paper, cloth or cardboard) may be placed under the microscope to avoid scratching it or the desk top.

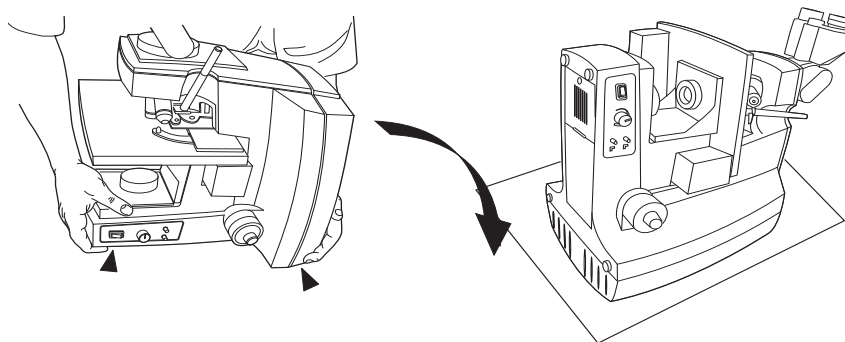


Figure 5-3 Position the Scope On Its Back Cover

- Using the supplied #2 Phillips Head screw driver, loosen the screw of the illuminator assembly door. Open the door to access the lamp bracket. (Refer to Figure 5-4.)

Note: The screw is mounted to the door - loosen the screw enough to get the door open, but do not remove it entirely.

5

REVIEW SCOPE MAINTENANCE

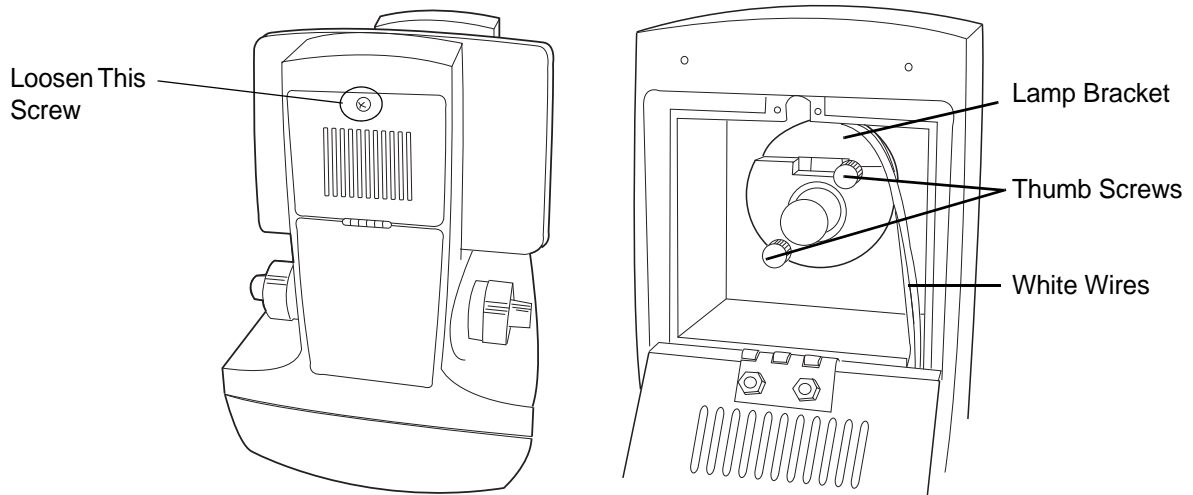


Figure 5-4 Illuminator Assembly Access and Lamp Bracket

WARNING: Hot Surfaces
Glass

Note: Observe the orientation of the lamp bracket assembly before removing it. The white wires should come out from the top of the assembly.

6. Loosen the two thumb screws that hold the lamp fixture to the bracket and pull it out to access the light bulb.

CAUTION: Do not touch the bulb with your fingers. Use gloves or a piece of gauze. Fingerprints on the glass will significantly reduce the bulb life.

7. Make sure the bulb is cool enough to handle. Use gloves or a piece of gauze to remove the old light bulb by pulling it out of the pin holes and replace it with a new bulb. *Fingerprints on the glass may damage the halogen light bulb - do not touch it with your bare hands.*

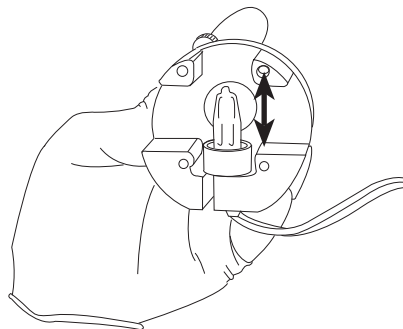


Figure 5-5 Replace the Illuminator Halogen Light Bulb

8. Return the lamp fixture to the holding bracket, seating it flat against the bracket. Tighten the thumb screws. Confirm that the wires come out from the top of the fixture (Refer to Figure 5-4). Be sure the wires are not pinched when the thumb screws are tightened.
9. Close the access door and tighten the Phillips Head screw to hold it shut.
10. Carefully set the scope upright. Test the new bulb by plugging in the microscope power cord and turning on the illuminator power switch.
11. Replace the collector filter, eye pieces and communication cables.

**SECTION
D****REPLACING THE FUSES**

There are user-accessible fuses located in the microscope. If the fuses must be replaced, follow the outline below:

WARNING: Instrument Fusing

1. Turn off the microscope (if it is on).
2. Remove the power cord from the wall outlet.
3. Remove the power cord from the receptacle on the rear of the microscope.
4. Using the small (#1) slotted screwdriver provided with the Review Scope, carefully pry open the cover of the power entry module as shown. (Refer to Figure 5-6.)

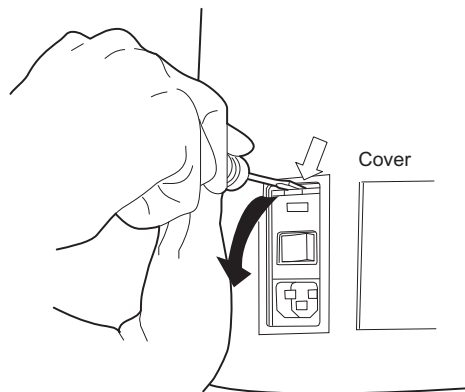


Figure 5-6 Open the Fuse Cover

5. Gently pull down the cover. It is hinged at the bottom end.
6. Insert the screwdriver under the fuse holder to pull it out. (Refer to Figure 5-7.)

5

REVIEW SCOPE MAINTENANCE

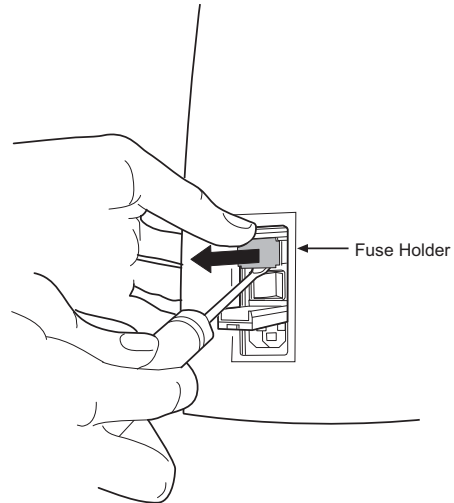


Figure 5-7 Remove the Fuse Holder

7. Note the position of the fuses in the holder, so that the new fuses will be inserted the same way.
8. Remove the existing fuses and discard them.
9. Insert the new 2.5A, 250T fuses into the fuse holder. (Refer to Figure 5-8.)

Refer to Ordering Information for ordering fuses.

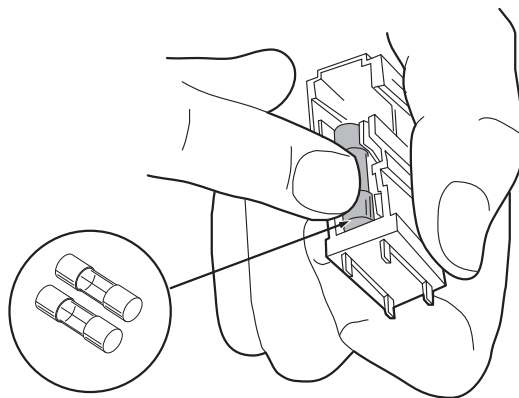


Figure 5-8 Insert New Fuse

10. Insert the fuse holder back into the power entry module. The module can only be inserted in one direction. (Refer to Figure 5-9.)
11. Close the access cover.

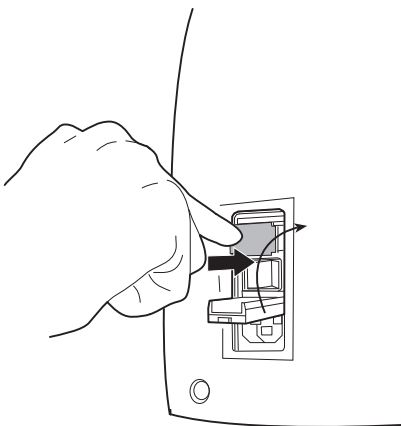


Figure 5-9 Install the Fuse Holder

12. Plug the power cord into the socket on the microscope.
13. Reattach the power cord to the wall outlet.
14. Turn on the microscope.
15. If the microscope still fails to operate, contact Hologic Technical Support.

SECTION
E

KOEHLER ALIGNMENT

Koehler illumination provides uniform, bright illumination across the entire field of view, with minimal glare. Alignment of the light path may be done as needed.

1. Load a slide with cells on it into the slide holder. Bring the specimen into focus at 10X.
2. Reduce the collector (field iris) (A) aperture to its smallest diameter by turning the collar of the collector diaphragm. Release the locking lever to allow the condenser to move up or down. Focus (sharpen the contrast of the edges of the aperture) by adjusting the condenser up or down (B). Refer to Figure 5-10. Tighten the locking lever when condenser adjustment is done.
3. Open the collector (field iris) aperture until it is slightly smaller than the field of view. Rotate the two condenser centering thumbscrews to center the aperture (C).
4. Open the collector aperture until it just disappears from view (A).
5. Adjust the condenser aperture to achieve desired contrast control by moving the condenser diaphragm adjustment lever (D) left or right to close or open the aperture.

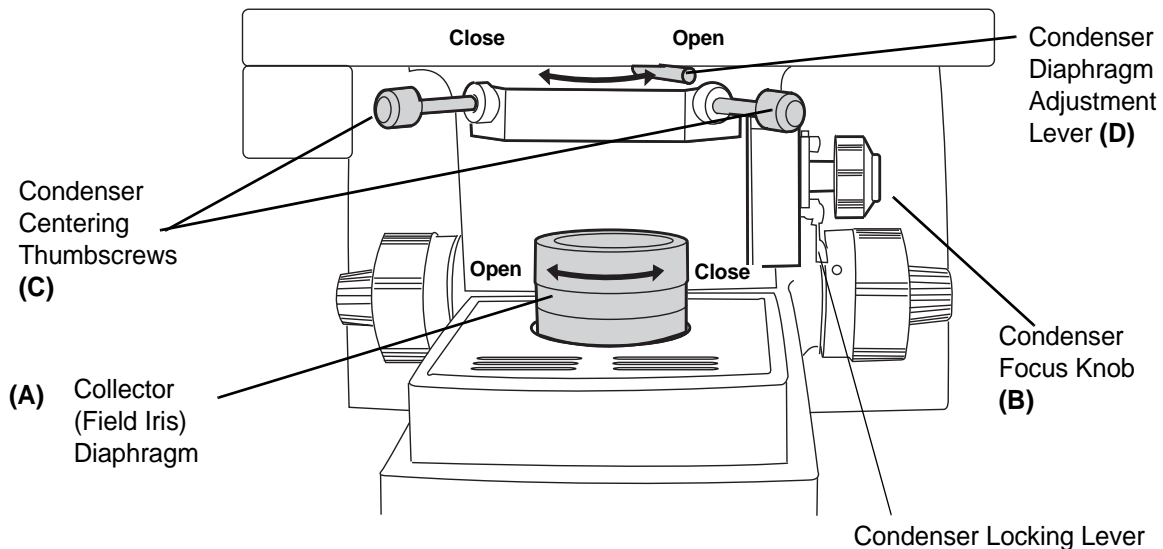


Figure 5-10 Condenser Assembly and Collector

Review Scope Maintenance for the Month _____

Reference: Frequency:	page 5.1 DAILY	page 5.1 DAILY	page 5.1 Monthly or As Needed	Chapter Five As Needed
DAY	Joystick Calibration (4-button pod only)	Marker Calibration	General Cleaning	Replacement of light bulb/fuse
1				
2				
3				
4				
5				
6				
7				
8				
9				
10				
11				
12				
13				
14				
15				
16				
17				
18				
19				
20				
21				
22				
23				
24				
25				
26				
27				
28				
29				
30				
31				

This page is for photocopy purposes.



5 REVIEW SCOPE MAINTENANCE

This page intentionally left blank.

Chapter Six

Troubleshooting

Review Scope errors fall into three groups - operation errors, user-correctable system errors and recoverable system errors. The following sections describe each group.

SECTION
A

OPERATION ERRORS

The Review Scope communicates operation errors to the user via an audible beep and a text message on the console. These messages indicate a condition where routine operation cannot continue without user input or acknowledgment.

Table 6.1: Text Messages on the Console Display

Error Message	Possible Cause	Corrective Action
Bad OCR Read or Bad Barcode Read	Wrong kind of slide or slide label. Wrong accession ID format. Label misprint. Label damaged. Label placement is incorrect. Slide not loaded correctly. Foreign object interferes with scan. Slide ID misprint. Slide ID reader malfunction.	<ul style="list-style-type: none"> • Confirm that a ThinPrep® Imaging System microscope slide is present and appropriately labeled. • Load the slide, with the frosted side up and toward the left. Seat the slide firmly against the left & rear sides of the slide holder. • Confirm that nothing is impeding the line of sight between the slide ID camera and the slide. • Manually enter the slide ID via the keypad (if OCR format). If the message persists, contact Hologic Technical Support.
Cell Spot Alignment Error	During Manual Review mode, the edge of the cell spot was not successfully aligned with the illuminated mark indicator. The slide was moved out of acceptable range. Or cell spot not found.	<ul style="list-style-type: none"> • Confirm that the slide is loaded correctly on the stage. • Check the quality and cleanliness of the slide.
Data Error	The slide was imaged but the data is corrupt. The slide ID is in the Server database.	Perform a manual review of the slide.

Table 6.1: Text Messages on the Console Display

Error Message	Possible Cause	Corrective Action
Error Initializing Network	Network connection cannot be made. Cabling not connected.	Check that the network cable is securely plugged into the rear of the Review Scope. If the error persists, contact Hologic Technical Support.
Imaging Not Successful	The Image Processor attempted to image the slide and did not succeed. (For example, excessive bubbles, too dense, etc.) The slide ID is in the Server database.	Perform a manual review of the slide.
Incorrect Software Version	An incorrect version of software was detected at power on.	Contact Hologic Technical Support.
Invalid ID Already Logged In	That Login ID has already been entered and a review session is open.	If a wrong ID has been mistakenly entered, press the Back softkey and enter a different ID. If a second session is meant to be opened with the same ID, press the Continue softkey.
Invalid ID Does Not Exist	Login ID doesn't exist. Login had wrong number of digits. Login ID has been retired.	<ul style="list-style-type: none"> • Retry using a valid Login ID. • Consult your Lab Administrator.
Invalid Slide ID	Wrong accession ID format.	<ul style="list-style-type: none"> • Use the correct 7-over-7 label format and OCR-A font (if using OCR) • Manually type in all 14 digits via the console keypad (if it is OCR format) • Check that the barcode formats are within limits.
Joystick Cal. Failed	During calibration, the joystick was not deflected greater than 50% in each direction. Joystick malfunction.	<ul style="list-style-type: none"> • Retry joystick calibration. Be sure to press the joystick fully to the extent of its movement in each outward direction. (See Joystick Calibration page 4.4.) • If the error persists, contact Hologic Technical Support.
Load Test Slide, Press Next	A test slide must be loaded during preferences scan/speed test movements.	<ul style="list-style-type: none"> • Load a slide and press Next on the pod.

Table 6.1: Text Messages on the Console Display

Error Message	Possible Cause	Corrective Action
Server Communication Error	Communication between the Review Scope and the Server failed.	<ul style="list-style-type: none"> • Press the “Retry” soft key on the console when prompted. • Check that the IPC with Server has not been turned off or is not malfunctioning. • Confirm that all cable connections to the RS and the IPC are secure. • If the error persists, contact Hologic Technical Support.
Slide Not Found	The slide ID is not in the database.	Either do a manual review or return the slide for imaging at the Image processor.
Slide Already Reviewed	The slide has already completed review at a Review Scope. The ID and data are in the Server database.	<ul style="list-style-type: none"> • Press the “Continue” soft key and proceed with a subsequent review. • Press the “Cancel” key if a subsequent review is not desired. • Run a Slide Data Record query on the Imager User Interface to confirm that the slide has been imaged.
Slide Removed	The slide was removed prior to being prompted by software. The slide shifted. Slide Present Sensor malfunction.	<ul style="list-style-type: none"> • Do not remove a slide from the stage during review. • To terminate a slide review, press the “Cancel” soft key and proceed to the Unload Slide prompt. • Make sure the slide present sensor is clean (see General Cleaning, page 5.1). • If the message persists, contact Hologic Technical Support.
Slide Review Cancelled	The “Cancel” soft key has been pressed. The operator has rejected pen marks or fiducial marks and cancelled the review.	Slide review is not complete until the “Review Complete Unload Slide” message is displayed. Do not remove the slide until prompted.

6 TROUBLESHOOTING

SECTION B

USER-CORRECTABLE ERRORS

These are system errors that halt operation of the Review Scope. The error number and name will appear on the console display. An audible beep also alerts the operator to the error condition. The Review Scope must be restarted (power off and then on) to clear the error message and resume normal operation.

```
* ERROR XXXX *
[error text]
Operation Halted
RESTART
```

Example of Error Format

```
* ERROR 7231 *
Moving Stage
Operation Halted
RESTART
```

Example of an Error

The errors are logged in memory and are retained for future viewing or printing from the Imager User Interface. The Open Error History selection in the RS menu will display the last 100 errors, ordered from the most recent to the oldest, 1 through 100. (If more errors occur, the oldest is deleted and the newest one added to the list.) The RS error log may also be viewed via the user interface at the Image Processor.

Error Number		Date and Time
4	7182	11241306
5	7330	10130842
6	7203	10011145

Log Sequence, 1 -100
Most Recent

Oldest ↓

Scrolls Through the Error Log

MM DD HH MM

Back More

Clearing a User-Correctable Error (Restart)

When a user-correctable error occurs, remove the slide from the stage, if one is present. Turn the power switch to the Off position. Refer to Figure 2-3, Review Scope, Rear.

Confirm that the moving parts of the Review Scope (nosepiece, stage, marking pen arm) are not impeded by any objects. Check that cable connections are secure and safely routed to avoid being pinched, pulled out, tripped over, etc.

Turn the power switch to the On position.

If user-correctable errors persist, contact Hologic Technical Support.

Table 6.2 lists the text messages that may be displayed for a user-correctable error. Restart the Review Scope as prompted.

Table 6.2: User-Correctable System Errors

Error	Error Text	Corrective Action
7020	Moving Nosepiece	Check for physical interference of nosepiece. Check for proper seating of objectives. Lower the stage with the coarse focus knob. Power cycle the RS.
7021	Moving Stage	Check for physical interference of nosepiece. Check for proper seating of objectives. Lower the stage with the coarse focus knob. Power cycle the RS.
7022	Moving Nosepiece	Check for physical interference of nosepiece. Check for proper seating of objectives. Lower the stage with the coarse focus knob. Power cycle the RS.
7023		
7081	Pod not present	Turn RS power off. Plug in Pod and / or console. Turn RS power on.
7082	Homing Nosepiece	Check for physical interference of nosepiece. Check for proper seating of objectives. Lower the stage with the coarse focus knob. Power cycle the RS.
7083	Homing Stage	Check for physical interference of nosepiece. Check for proper seating of objectives. Lower the stage with the coarse focus knob. Power cycle the RS.
7084	Homing Marker	Remove the pen. Power cycle the RS. Complete Post Marker Calibration (menu option 3). Insert Pen when prompted.
7085	Initializing OCR	Power cycle the RS.
7088	Speaker Initialization	Power cycle the RS.
7089	RTClock Fault	Power cycle the RS.
7090	Moving Stage	Check for physical interference of nosepiece. Lower the stage with the coarse focus knob. Power cycle the RS.

Table 6.2: User-Correctable System Errors

7091	Toggle Nosepiece	Check for physical interference of nosepiece. Check for proper seating of objectives. Lower the stage with the coarse focus knob. Power cycle the RS.
7092	Serial Number	Power cycle the RS. If the problem is not resolved, contact Technical Support.
7100	Moving stage	Check for physical interference of nosepiece. Check for proper seating of objectives. Lower the stage with the coarse focus knob. Power cycle the RS.
7101	Joystick disable	Power Cycle the RS. Calibrate the joystick (menu option 2). If the problem is not resolved, contact Technical Support.
7120	Moving Nosepiece	Check for physical interference of nosepiece. Check for proper seating of objectives. Lower the stage with the coarse focus knob. Power cycle the RS.
7121	Moving Stage	Check for physical interference of nosepiece. Check for proper seating of objectives. Lower the stage with the coarse focus knob. Power cycle the RS.
7122	FOI Corrupted	Power Cycle the RS. If the problem is not resolved, contact Technical Support.
7130	Moving Nosepiece	Check for physical interference of nosepiece. Check for proper seating of objectives. Lower the stage with the coarse focus knob. Power cycle the RS.
7131	Moving Stage	Check for physical interference of nosepiece. Check for proper seating of objectives. Lower the stage with the coarse focus knob. Power cycle the RS.
7132	MTZ Corrupted	Power Cycle the RS. If the problem is not resolved, contact Technical Support.
7140	Moving Stage	Check for physical interference of nosepiece. Check for proper seating of objectives. Lower the stage with the coarse focus knob. Power cycle the RS.
7151		
7152		

Table 6.2: User-Correctable System Errors

7153	Readying Pen	Check for pen obstruction. Power cycle the Review Scope to see if the error clears. Perform marker calibration (menu option 3).
7154	Moving Stage	Check for physical interference of nosepiece. Check for proper seating of objectives. Lower the stage with the coarse focus knob. Power cycle the RS.
7155		
7156	Capping Pen	Check for pen obstruction. Power cycle the Review Scope to see if the error clears. Perform marker calibration (menu option 3).
7161	Joystick Move	Recalibrate Joystick (menu option 2). If Recalibration doesn't fix the problem, try new Pod and Recalibrate Joystick. a. Turn RS power off b. Unplug the Pod. c. Plug in a new Pod. d. Turn RS power on. e. Recalibrate the Joystick.
7166	Disable X Motor	Power Cycle the RS. If the problem is not resolved, contact Technical Support.
7167	Disable Y Motor	
7190	Moving Stage	Check for physical interference of nosepiece. Check for proper seating of objectives. Lower the stage with the coarse focus knob. Power cycle the RS.
7191	Readying Pen	Check for pen obstruction. Power cycle the Review Scope to see if the error clears. Perform marker calibration (menu option 3).
7192	Marking Slide	
7193	Capping Pen	
7194	Moving Stage	Check for physical interference of nosepiece. Check for proper seating of objectives. Lower the stage with the coarse focus knob. Power cycle the RS.
7195		
7196	Reset X Location	Check for interferences and remove any obstructions. Power cycle the RS.
7197	Moving Stage	Check for physical interference of nosepiece. Check for proper seating of objectives. Lower the stage with the coarse focus knob. Power cycle the RS.

Table 6.2: User-Correctable System Errors

7198	Capping Pen	Check for pen obstruction. Power cycle the Review Scope to see if the error clears. Perform marker calibration (menu option 3).
7200	Moving Nosepiece	Check for physical interference of nosepiece. Check for proper seating of objectives. Lower the stage with the coarse focus knob. Power cycle the RS.
7201	Moving Stage	Check for physical interference of nosepiece. Check for proper seating of objectives. Lower the stage with the coarse focus knob. Power cycle the RS.
7202	Readying Pen	Check for pen obstruction. Power cycle the Review Scope to see if the error clears. Perform marker calibration (menu option 3).
7203	Capping Pen	
7204	Marking Slide	
7205	MTZ Corrupted	Power Cycle the RS. If the problem is not resolved, contact Technical Support.
7207	Moving Stage	Check for physical interference of nosepiece. Check for proper seating of objectives. Lower the stage with the coarse focus knob. Power cycle the RS.
7209		
7210	Moving Nosepiece	Check for physical interference of nosepiece. Check for proper seating of objectives. Lower the stage with the coarse focus knob. Power cycle the RS.
7211	Moving Stage	Check for physical interference of nosepiece. Check for proper seating of objectives. Lower the stage with the coarse focus knob. Power cycle the RS.
7220	Moving Nosepiece	Check for physical interference of nosepiece. Check for proper seating of objectives. Lower the stage with the coarse focus knob. Power cycle the RS.
7221	Moving Stage	Check for physical interference of nosepiece. Check for proper seating of objectives. Lower the stage with the coarse focus knob. Power cycle the RS.

Table 6.2: User-Correctable System Errors

7222	Moving Nosepiece	Check for physical interference of nosepiece. Check for proper seating of objectives. Lower the stage with the coarse focus knob. Power cycle the RS.
7223		
7224	Moving Stage	Check for physical interference of nosepiece. Check for proper seating of objectives. Lower the stage with the coarse focus knob. Power cycle the RS.
7225	Moving Nosepiece	Check for physical interference of nosepiece. Check for proper seating of objectives. Lower the stage with the coarse focus knob. Power cycle the RS.
7230		
7231	Moving Stage	Check for physical interference of nosepiece. Check for proper seating of objectives. Lower the stage with the coarse focus knob. Power cycle the RS.
7232	Moving Nosepiece	Check for physical interference of nosepiece. Check for proper seating of objectives. Lower the stage with the coarse focus knob. Power cycle the RS.
7233		
7234	Moving Stage	Check for physical interference of nosepiece. Check for proper seating of objectives. Lower the stage with the coarse focus knob. Power cycle the RS.
7235	Moving Nosepiece	Check for physical interference of nosepiece. Check for proper seating of objectives. Lower the stage with the coarse focus knob. Power cycle the RS.
7240		
7241	Moving Stage	Check for physical interference of nosepiece. Check for proper seating of objectives. Lower the stage with the coarse focus knob. Power cycle the RS.
7242	Moving Nosepiece	Check for physical interference of nosepiece. Check for proper seating of objectives. Lower the stage with the coarse focus knob. Power cycle the RS.
7243		
7244	Moving Stage	Check for physical interference of nosepiece. Check for proper seating of objectives. Lower the stage with the coarse focus knob. Power cycle the RS.

Table 6.2: User-Correctable System Errors

7245	Moving Nosepiece	Check for physical interference of nosepiece. Check for proper seating of objectives. Lower the stage with the coarse focus knob. Power cycle the RS.
7246	Moving Stage	Check for physical interference of nosepiece. Check for proper seating of objectives. Lower the stage with the coarse focus knob. Power cycle the RS.
7250		
7251		
7252		
7253		
7254		
7255		
7256		
7257		
7270		
7273	Moving Nosepiece	Check for physical interference of nosepiece. Check for proper seating of objectives. Lower the stage with the coarse focus knob. Power cycle the RS.
7274	Lowering Pen	Check for pen obstruction. Power cycle the Review Scope to see if the error clears. Perform marker calibration (menu option 3).
7275	Homing Nosepiece	Check for physical interference of nosepiece. Check for proper seating of objectives. Lower the stage with the coarse focus knob. Power cycle the RS.
7280	Readying Pen	Check for pen obstruction. Power cycle the Review Scope to see if the error clears.
7281	Capping Pen	
7282	Moving Stage	Check for physical interference of nosepiece. Check for proper seating of objectives. Lower the stage with the coarse focus knob. Power cycle the RS.
7283	Capping Pen	Check for pen obstruction. Power cycle the Review Scope to see if the error clears.
7284	Lowering Pen	
7285	Raising Object Marker	

Table 6.2: User-Correctable System Errors

7286	Moving Stage	Check for physical interference of nosepiece. Check for proper seating of objectives. Lower the stage with the coarse focus knob. Power cycle the RS.
7287	Readying Pen	Check for pen obstruction. Power cycle the Review Scope to see if the error clears.
7325	Network Connection	Check that all cabling is secure. Power cycle the RS.
7330	Moving Stage	Check for physical interference of nosepiece. Check for proper seating of objectives. Lower the stage with the coarse focus knob. Power cycle the RS.
7340	Moving Nosepiece	Check for physical interference of nosepiece. Check for proper seating of objectives. Lower the stage with the coarse focus knob. Power cycle the RS.
7341		
7350		
7351		
7360		
7361		
7380	X Dac Zero	Power Cycle the RS. If the problem is not resolved, contact Technical Support.
7381	X Velocity Zero	
7382	Y Dac Zero	
7383	Y Velocity Zero	
7384	Nose Dac Zero	
7385	Nose Velocity Zero	
7386	OM DacA Zero	
7387	OM DacB Zero	
7423	Server Communication	Contact Technical Support.
7450	Moving Stage	Check for physical interference of nosepiece. Check for proper seating of objectives. Lower the stage with the coarse focus knob. Power cycle the RS.
7451	Imaging Slide	Power Cycle the RS.

Table 6.2: User-Correctable System Errors

7452	Moving Scan Position X	Check for interferences and remove any obstructions. Power cycle the RS.
7453	Move to 40X	Check for physical interference of nosepiece. Lower the stage with the coarse focus knob. Power cycle the RS.
7454	Move to 10X	
7455	Moving Stage	Check for physical interference of nosepiece. Check for proper seating of objectives. Lower the stage with the coarse focus knob. Power cycle the RS.
7456	Move To Mzone	Check for pen obstruction. Power cycle the Review Scope to see if the error clears. Perform marker calibration (menu option 3).
7457	Move to Msite (Marking Site)	Check for interferences and remove any obstructions. Power cycle the RS.
7458	Mark the Site	Check for pen obstruction. Power cycle the Review Scope to see if the error clears. Perform marker calibration (menu option 3).
7461	Next Mark Site	Check for interferences and remove any obstructions. Power cycle the RS.
7462	Prep Pen	Check for pen obstruction. Power cycle the Review Scope to see if the error clears. Perform marker calibration (menu option 3).
7463	Initial Load Position	Check for interferences and remove any obstructions. Power cycle the RS.
7464	Homing Stage	Check for physical interference of nosepiece. Check for proper seating of objectives. Lower the stage with the coarse focus knob. Power cycle the RS.

SECTION
C**RECOVERABLE SYSTEM ERRORS**

These are errors from which the system automatically recovers. Review Scope operation continues uninterrupted. No message is signaled to the operator. The errors are logged in the Error Log and may be viewed from the console display or at the user interface at the Image Processor.

No operator action is required.

SECTION
D**MISCELLANEOUS****User preferences do not stay as they were selected.**

- Preferences aren't stored until Logout has been performed.
- Confirm the correct user ID was entered at Login.

Fiducial marks presented out of the field of view.

- Ensure the slide is properly loaded and registered against the back and left side of the slide holder.
- Try adjusting the focus knob, in case the slide is out of focus.

The Mark button on the pod does not work.

- The electronic mark is only made when the magnification is 10X. Make sure the objective is at 10X. Make sure the nosepiece movement is not obstructed.
- Check that the pod button being pressed is actually configured to be the Mark button. (See Button Setup, page 4.24.)
- Make sure the illumination intensity for the mark indicator is high enough to be seen. (Lower right side of the microscope.)
- Check the Koehler illumination, particularly the setting of the field iris diaphragm. (See Koehler Alignment, page 5.8.)

The electronic mark indicator is not visible.

- Make sure the illumination intensity for the mark indicator is high enough to be seen. (Lower right side of the microscope.)
- The electronic mark indicator is only displayed at 10X magnification. It will not be visible at 40X.
- The user preference "Mark Turns OFF" has been selected. The white mark indicator is not visible during autolocate moves. (See Mark Indicator, page 4.20.)

6 TROUBLESHOOTING

“Server Communication Error” or “Error Initializing Network” occurs at power up or while reviewing slides.

- Communication between the Review Scope and Server has been interrupted. Check if the server is turned on.
- Check that the network cables from the server to the hubs and the hubs to the RS are securely connected.
- Make sure the network devices are plugged in (power is on).

Slide is removed but the console display does not respond.

- Clean the slide present sensor with a cotton swab and alcohol. (Refer to Figure 5-1, Slide Present Sensor.)

Patient slide is cracked or broken after imaging.

- Cracked slides should be manually reviewed. Treat cracked or broken slides according to your established laboratory guidelines.

Chapter Seven

Definitions and Abbreviations

Autolocate

During Auto Review, the 22 fields of view containing objects of interest identified by the Imager are presented to the CT by automatically positioning the slide, according to the coordinates of the objects' location. The fields of view are presented according to geographic location on the slide, NOT by any order of diagnostic significance. The user may preset the speed at which the microscope stage advances from field of view to field of view. The user initiates the movement from site to site by using the function buttons on the pod.

Autoscan

If any area of the cell spot is electronically marked during slide review, the entire cell spot must be scanned in order to complete the slide review process. The microscope stage automatically moves the slide in a prescribed path for viewing the cells. The user may preset the speed, direction and type of motion of the autoscan. The scan may be paused and resumed by the user.

Cassette

The container that holds slides for batch processing. Each cassette may hold up to 25 slides.

Cell Spot

The area within the pre-printed arcs on a ThinPrep[®] Microscope Slide that contains the patient's cells.

Collector Iris Diaphragm

Also known as the field diaphragm or field stop. Controls the size (diameter) of the column of light emitting from the collector.

Condenser Iris Diaphragm

Also known as the aperture diaphragm or lens stop. Controls the angle of the cone of light reaching the specimen.



DEFINITIONS AND ABBREVIATIONS

Console

An input-output user interface for operating the Review Scope when the user's visual attention is not required for viewing in the microscope. The console has ten numeric keys, a cancel key and two 'soft' keys (used for menu functions). The LCD display provides menus, prompts and other messages for the user.

CRC

Cyclic Redundancy Check. This is a frequent, routine software check of the data and communications to ensure the integrity of the processed data.

CT

Cytotechnologist

Fiducial Marks

Permanently printed marks on the ThinPrep[®] microscope slide used as a reference axis to establish the coordinates of objects of interest. The fiducial marks are also used to register the slide position on the Review Scope stage at the beginning and end of slide review.

FOV

Field of View. A circular area of the slide, as viewed through the microscope.

IP

Image Processor. The components of the ThinPrep Imaging System including the Imaging Station, the Image Processor Controller, the Server and the User Interface.

IPC

Image Processor Controller. The component of the Image Processor that contains the Server, hard drives and processors that control the imaging system.

IS

Imaging Station. The component of the Image Processor which houses the slide cassettes and where the imaging process takes place.

Joystick

The round control in the center of the pod, used to move the microscope stage or set its speed while viewing cells through the microscope.

Koehler Illumination

A microscope alignment technique that establishes optimal lens positions and iris diaphragm sizes with respect to the specimen plane and objective field of view to provide bright, even illumination of the specimen.

Manual Review

A patient slide is screened at a Review Scope, but the system server database is not queried to find and retrieve associated slide data. The review results are not stored on the server database.

Mark Indicator

An 'L' shaped illuminated pattern in the field of view. When white in color, it indicates to the user that the area can be electronically marked. When green in color, it indicates to the user that the area is electronically marked (the presence of a Marked Target Zone). Areas marked green will be physically marked on the slide at the conclusion of the slide review.

MTZ

Marked Target Zone. A 0.50 mm x 0.50 mm area of the slide that has been electronically targeted for physical marking by the pen at the conclusion of slide review. Areas targeted to be marked show as a green 'L' shape by the Mark Indicator stencil in the optical path. Target areas may be selected and deselected for marking right up until physical marking takes place.

Network Device

A hub or switch or interconnection device that allows signal communication between the components of the Imaging System.

Object Marker

The object marker is a marking pen seated in a mechanical arm attached to the Review Scope frame. At the end of slide review, any areas on the slide that the cytotechnologist has electronically tagged for marking are physically marked with the pen. All slides that have undergone review at the Review Scope will bear a Slide Reviewed mark, made by the marking pen.



DEFINITIONS AND ABBREVIATIONS

OCR

Optical Character Recognition. The Imaging Station and the Review Scope each contain a slide ID camera that can read a slide label ID in OCR format and matches it against the patient ID's already stored in the Server database.

OOI

Object of Interest. A blob that has passed filtering (which removes most normal cells and recognized artifacts) and has been ranked by nuclear integrated optical density. An object of interest may be a single cell or a cluster.

Pod

The pod is used by the operator at the review scope to manipulate stage motion to view the slide through the scope. The pod also functions to toggle the nosepiece to change objective magnification, to step forward or backward through menus or cell locations, to electronically mark and unmark suspect cells.

Power Cycle

Turning the Review Scope Off and then On, using the power switch. This is done to recover from system errors that halt operation of the RS.

RS

Review Scope.

Site

The set of coordinates (as referenced from the fiducial marks on the ThinPrep® microscope slide) that centers the area to be reviewed within the field of view.

Slide Data Record

The data associated with a specific accession ID/slide. The data is stored on the Server database. It is generated at the time a slide ID is successfully scanned in the Imaging Station prior to imaging. The data record is updated when the slide has been imaged and image analysis completed and again when the slide has completed automated review at the RS.



Slide Registration

The slide is registered to the microscope stage by aligning its fiducial marks with the mark indicator stencil in the optical path. This functions to ensure that the OOI coordinates for the slide ID coincide with the cells scanned on the Image Processor. The slide registration is established before and confirmed after automated slide review, to check that no drift has occurred during review.

Manual slide review aligns the edges of the cell spot with the mark indicator before and after screening to confirm slide registration.

Slide Reviewed Mark

A mark made on the surface of the slide by the object marker in semi-permanent ink. The slide reviewed mark indicates the slide has undergone review at an RS.

A slide that has undergone Auto review has the mark placed on the top arc of the ThinPrep® slide.

A slide that has undergone Manual review has the mark placed on the bottom arc of the ThinPrep slide.

Subsequent Review

A slide that has undergone Auto Review at the Review Scope may be screened again, using the slide data associated with that slide. In this Operator's Manual, subsequent review means additional screenings of a slide, using the Auto Review mode, which is recorded on the server database. (Further review of slides using the manual mode are not recorded to the server database.)

SV

Server. The computer that controls communication between the Imaging System components. It is where all data such as user preferences, slide data records, system history logs are maintained.

ThinPrep Microscope Slide

A specific brand of glass microscope slide that must be used with the ThinPrep® system of instruments. The slide has features on it that enable automated registration of the slide with the Imaging Station and the Review Scope.

Soft Keys

Two software-definable keys located on the RS console, used to make specific selections or actions, associated with the labels on the display directly above the key. Soft key functions and availability will change depending on the current software operational state or mode.



DEFINITIONS AND ABBREVIATIONS

Verification Slide

This is a special slide that has custom features that allow for periodic system verification.



Chapter Eight

Service Information

Corporate Address

Hologic, Inc.

250 Campus Drive

Marlborough, MA 01752 USA

Business Hours

Hologic's business hours are 8:30 a.m. to 5:30 p.m. EST Monday through Friday, excluding holidays.

Customer Service

Product orders, which include standing orders, are placed through Customer Service by phone during business hours at 1-800-442-9892 Option 5 or 508-263-2900.

Orders can also be faxed to the attention of Customer Service at 508-229-2795.

Warranty

A copy of Hologic's limited warranty and other terms and conditions of sale may be obtained by contacting Customer Service at the numbers listed above.

Technical Support

For questions about ThinPrep® Imaging System issues and related application issues, representatives from Technical Support are available by phone 7:00 a.m. to 7:00 p.m. EST Monday through Friday at 1-800-442-9892 Option 6 or 508- 263-2900.

Service contracts can also be ordered through Technical Support.

Protocol for Returned Goods

For returns on warranty-covered ThinPrep Imaging System accessory and consumable items, contact Technical Support.

Service contracts can also be ordered through Technical Support.



SERVICE INFORMATION

This page intentionally left blank.

Chapter Nine

Ordering Information

Mailing Address

Hologic, Inc.
250 Campus Drive
Marlborough, MA 01752

Remittance Address

Hologic
PO Box 3009
Boston, MA 02241-3009

Business Hours

Hologic's business hours are 8:30 a.m. to 5:30 p.m. EST Monday through Friday, excluding holidays.

Customer Service

Product orders, which include standing orders, are placed through Customer Service by phone during business hours at 1-800-442-9892 Option 5 or 508-263-2900.

Orders can also be faxed to the attention of Customer Service at 508-229-2795.

Warranty

A copy of Hologic's limited warranty and other terms and conditions of sale may be obtained by contacting Customer Service at the numbers listed above.

Protocol for Returned Goods

For returns on warranty-covered ThinPrep® Imaging System accessory and consumable items, contact Technical Support.

Table 9.1: Reordering Supply Items for the Review Scope

Item	Description	Quantity	Part Number
Slide Cassette, 10-pack	Additional slide cassettes	1 pkg	70773-001
Microscope Dust Cover	Dust cover	ea	03847-001
RS Navigator Pod	Replacement Pod assembly	ea	71061-001
RS Console	Replacement Console assembly	ea	71102-001
Fuses	2.5A, 250T Time Delay, Glass, Low Break Capacity replacement fuse	ea	50077-017
Halogen Light bulb	20W, 6V halogen glass replacement light bulb	ea	51337-002
Eyepiece, 10X, 24 mm	Replacement eyepiece (should be used in pairs)	ea	51815-001
Objective, 10X	Replacement 10X objective	ea	51199-001
Objective, 40X	Replacement 40X objective	ea	51200-001
Filter, LBD (light balanced, day-time), Optical	Additional filter (for collector lens)	ea	50852-001
Filter, Neutral Density, Optical	Additional filter for collector lens	ea	04322-001
Focus Knob Covers	Covers for fine focus knobs	2 ea	04815-001
Review Scope Operator's Manual	Additional Operator's Manual	ea	MAN-03352-001
Telescoping Head	Option for tilting head binoculars	ea	52029-001
Riser	Hologic riser	ea	ASY-03268



Index

A

Accessing Manual Mode 3.18
Align Cell Spot 3.19
Auto Review 3.1, 3.6
Auto Start-Stop Scan 4.16
Autolocate 3.10, 4.19
autolocate speed 4.19
Automatic Continuous 4.14
Automatic Start Stop 4.14
Autoscan overlap 4.18

B

Bad OCR Read 6.1
Beep Volume 4.23
Binocular Head 2.5
Button Setup 4.24

C

Cancel console key 3.6
Cancel key 2.8, 3.10
Cell Spot Alignment Error 6.1
Check the Slide Registration 3.15, 3.22
Clearing a user-correctable error 6.4
collector 2.9, 5.8
condenser 2.9, 5.8
Connect Review Station Components 2.3
Console 1.9, 1.12, 9.2
Continuous scan 4.15
Customer Service 8.1, 9.1



D

Daily Screening Rates 3.2
Data Error 6.1
Dimensions and Weight 1.12
Disposal 1.18

E

Environmental 1.10
Error Log 4.27
Errors 6.1
Eyepieces 2.5, 9.2

F

Finish soft key 3.14
Focus knob covers 2.6
Fuse 5.5, 9.2

G

General Cleaning 5.1

H

Halogen light bulb 5.2
Hazards 1.13



I

Illumination Control Panel 2.10
Imaging Not Successful 6.2
Imaging Slide 6.11
Incorrect Software Version 6.2
Installation 2.1
Internal Quality Control 1.13
Invalid Login 6.2
Invalid Slide ID 6.2

J

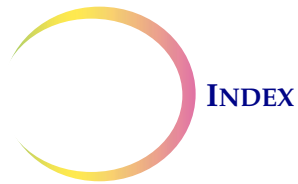
Joystick 2.9
Joystick Cal. Failed 4.5, 6.2
Joystick Calibration 4.4, 5.1
Joystick Setup 4.21

K

Koehler alignment 5.8
Koehler illumination 2.9

L

Lightbulb 9.2
Load Test Slide, Press Next 6.2
Login 4.3
Login ID 3.6
Login/Load Slide 3.6
Logout 4.3



M

Manual Review 3.2, 3.18
Manual Scan 3.20
Manual Slide Review 3.18
Manual soft key 3.19
Manual Start Stop 4.14
Manual Start-Stop Scan 4.18
Mark button 2.9, 3.10, 3.21, 4.25
mark indicator on/off 3.7, 4.20
Marker Calibration 5.1
Marking pen 2.6, 4.7, 4.9
material safety data sheet
 CytoLyt Solution 1.18
 PreservCyt Solution 1.18
Menu soft key 4.2
Microscope slide 1.10
Move to Msite 6.12
Moving Scan Position X 6.12
Moving the Review Scope 2.2

N

Next button 2.8, 3.10, 3.21, 4.24

O

Object button 3.21
object marker, priming 4.11
Objective button 2.8, 3.10, 4.25
Objectives, 10X, 40X 2.5, 9.2
Offline Soft Key 3.18
Open Error Log 4.27
Operation Errors 6.1
Operation of Software Menu 4.1
Operator's Manual 9.2



P

Physical Marking of the Slide 3.14, 3.21
Pod 1.9, 1.12, 2.8, 4.26, 9.2
Power 1.11
Power On 1.13
Preferences 4.13
Previous button 2.8, 3.10, 3.21, 4.25
Prime the marker 4.7, 4.9
prime the object marker 4.11
Protective Temperature Coefficient Devices 1.11

R

Recoverable System Errors 6.13
Register the Slide Fiducial Marks 3.8
Reject soft key 3.14, 3.15
Replacing the Illuminator Light Bulb 5.2
Reset Defaults 4.26
Reset soft key 3.13, 3.21
Restart 6.4
Review Marked Fields 3.12
Review soft key 3.12, 3.13, 3.21

S

Scan Direction 4.13
Scan Overlap 3.6, 4.18
Scan soft key 3.12
Scan Type 4.14
Server Communication Error 6.3
Setup Marker 4.6
Shut down 3.24
Skip soft key 4.7, 4.9
Slide Already Reviewed 6.3



Slide Cassette 9.2
slide labeling formats 1.10
Slide Not Found 6.3
Slide Removed 6.3
Slide Review Cancelled 6.3
Slide Reviewed Mark 3.15, 3.23
Slide Scanning 3.13
Soft keys 2.8
Specimen Adequacy 3.10, 3.12
specimen adequacy 3.10
Subsequent Review 3.1, 3.16

T

Technical Specifications 1.6
Technical Support 8.1
Troubleshooting 6.1

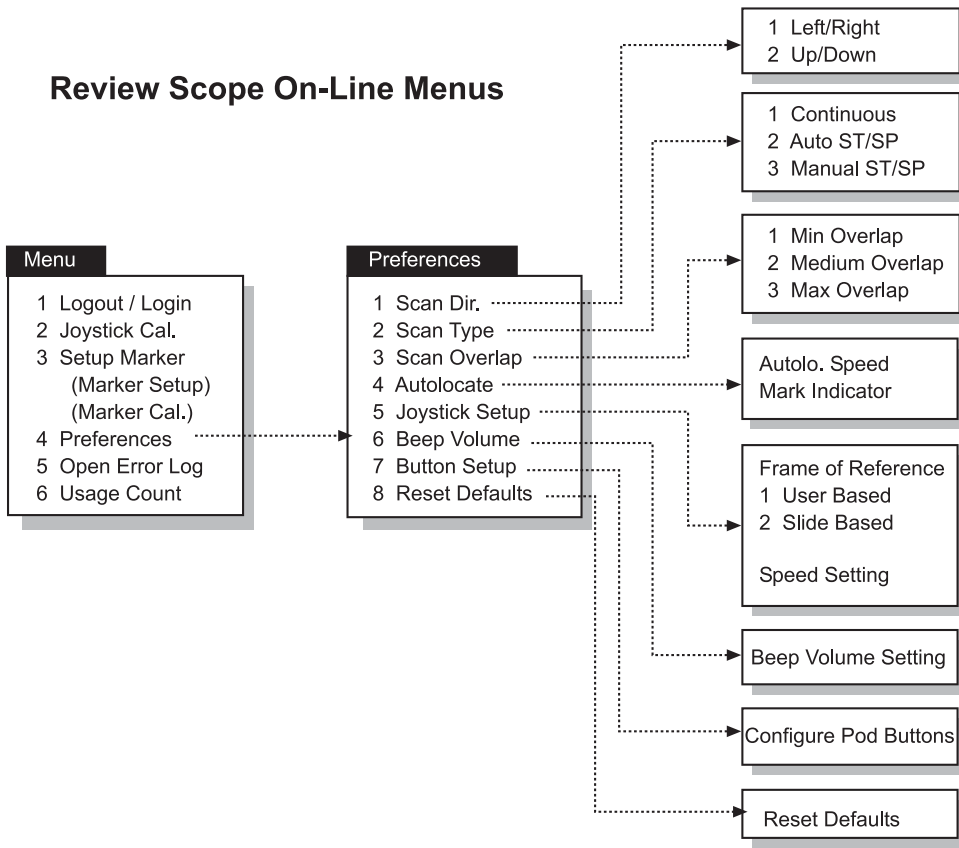
U

Usage Count 4.28
User-Correctable Errors 6.4

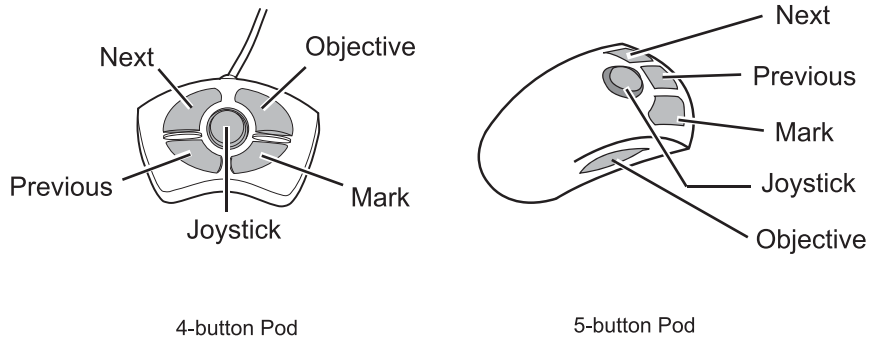
W

Warnings 1.13

Review Scope On-Line Menus



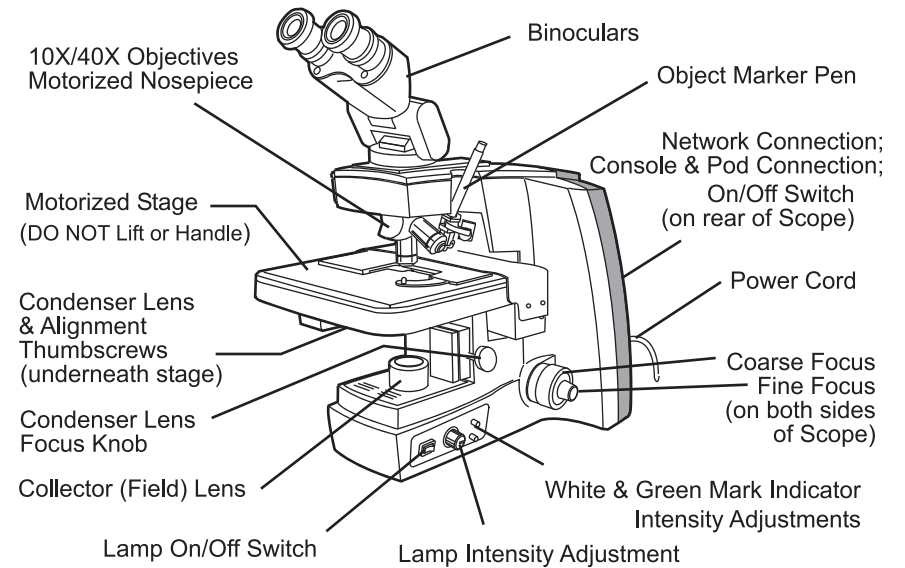
Pod (Default button configuration)



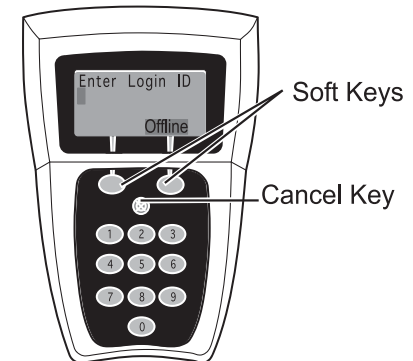
Note: Only one pod is used

Review Scope Quick Reference Guide

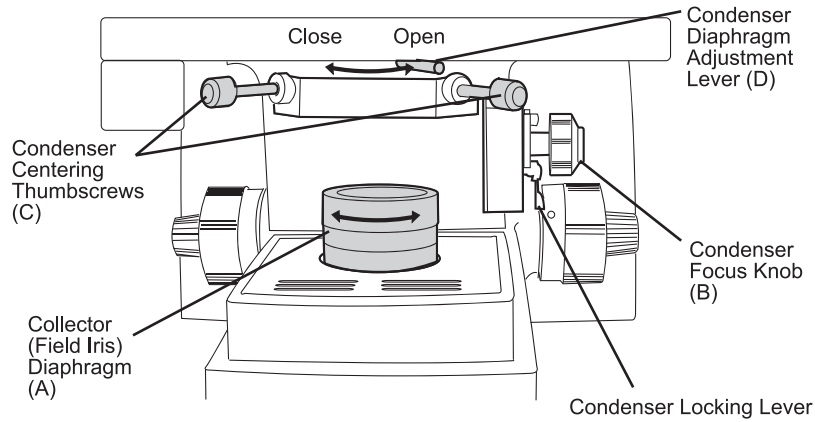
Review Scope Components



Console/Keypad

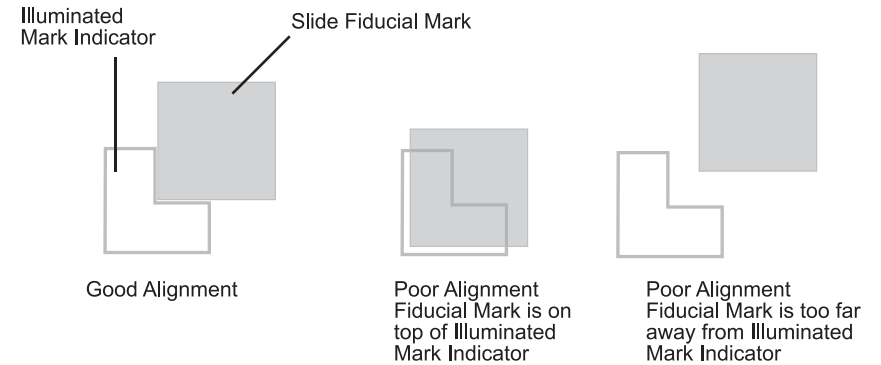


Koehler Alignment



1. Load a slide with cells on it into the slide holder. Bring the specimen into focus at 10X.
2. Reduce the collector (field iris) (A) aperture to its smallest diameter by turning the collar of the collector diaphragm. Release the locking lever to allow the condenser to move up or down. Focus (sharpen the contrast of the edges of the aperture) by adjusting the condenser up or down (B). Tighten the locking lever when condenser adjustment is done.
3. Open the collector (field iris) aperture until it is slightly smaller than the field of view. Rotate the two condenser centering thumbscrews to center the aperture (C).
4. Open the collector aperture until it just disappears from view (A).
5. Adjust the condenser aperture to achieve desired contrast control by moving the condenser diaphragm adjustment lever (D) left or right to close or open the aperture.

Fiducial Mark Alignment



Maintenance

Menu Option 2

Joystick Calibration 4-button pod DAILY 5-button pod as needed



1. Place your finger in the center of the joystick. Deflect the button outward to the farthest possible extent.
2. While maintaining full deflection, roll your finger in a circle 2 or 3 times to move the joystick in the widest possible circles.
3. Return the joystick to the center and let go.
4. Do not touch the joystick while calibration calculations are being performed.

Menu Option 3 Marker Calibration DAILY

1. Load a blank slide on the stage. Press Next button on the pod.
2. Focus on the top arc of the slide. Press the Continue key on the console.
3. Load a marker into the holder. Press the Done key. Or, if a marker is loaded, press the Skip key.
4. A test mark is made on the slide. Using the joystick, center the mark inside the outline of the 'L' shape mark indicator. Press the Next button on the pod.
5. Marker calibration is complete. Press the Continue key.

Hologic®

ThinPrep®

Review Scope

Operator's Manual



Hologic, Inc.
250 Campus Drive
Marlborough, MA 01752 USA
1-800-442-9892
1-508-263-2900
www.hologic.com

MAN-03352-001 Rev. 005