

# MammoSite® ml

Radiation Therapy System

## Polyurethane Balloon INSTRUCTION MANUAL

**HOLOGIC®**

**CAUTION:** Federal (USA) law restricts this device to sale by or on the order of a physician.



# Contents

## General Information

<b>Product Description</b> . . . . .	<b>2</b>
<b>Intended Use/Indications</b> . . . . .	<b>3</b>
<b>Contraindications</b> . . . . .	<b>3</b>
<b>Warnings</b> . . . . .	<b>4</b>
<b>Precautions</b> . . . . .	<b>5</b>

## Instructions for Use

<b>How Supplied</b> . . . . .	<b>6</b>
<b>MammoSite ML Device Placement Procedure</b> . . . . .	<b>7</b>
MammoSite ML Balloon Selection . . . . .	7
System Verification . . . . .	8
Applicator Placement . . . . .	8
Surgical Placement . . . . .	8
Post-Surgical Placement . . . . .	10
<b>Using The Keyed Stylet</b> . . . . .	<b>11</b>
<b>Radiation Therapy Delivery</b> . . . . .	<b>11</b>
<b>MammoSite ML Device Removal Procedure</b> . . . . .	<b>12</b>
<b>Technical Support</b> . . . . .	<b>13</b>
<b>For More Information and Warranty</b> . . . . .	<b>13</b>











## 1 General Information

# MammoSite® Multi-Lumen (MammoSite ML) Applicator Tray

**CAUTION:** Federal (USA) law restricts this device to sale by or on the order of a physician.

### Symbols Key

The following symbols may appear on the label or carton:

Symbol	Definition
	Batch Code
	Catalog number
	Caution
	Do not re-sterilise
	Do not re-use
	Do not use if package is damaged
	Fill Volume
	Manufacturer
	Size
	Sterilised using ethylene oxide
	Use-by date

**MammoSite ML products and their packaging are latex-free.**

Description	Catalogue Number	Balloon Size
MammoSite ML Variable 3.5–5 cm Applicator Tray Kit, plus Trocar and Introducer Sheath	ML2345	3.5–5 cm

**PRODUCT DESCRIPTION**

The MammoSite ML applicator is used to position tissue and the radioactive source during breast brachytherapy treatments. It consists of a multi-lumen polyurethane catheter with an inflatable balloon assembly at its distal end. Graduation marks are printed on the applicator body to assist in placement of the applicator. The marks are measured at 1 cm intervals. The MammoSite ML applicator is illustrated in Figures 1, 2 and 3.

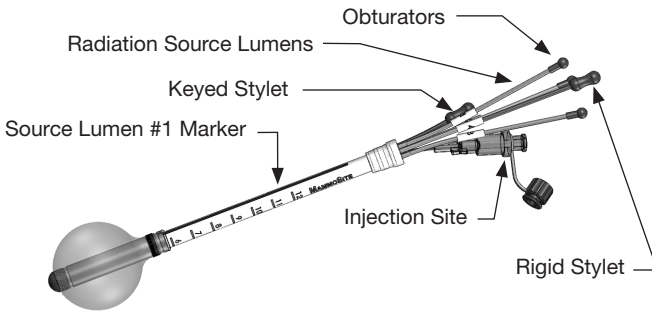
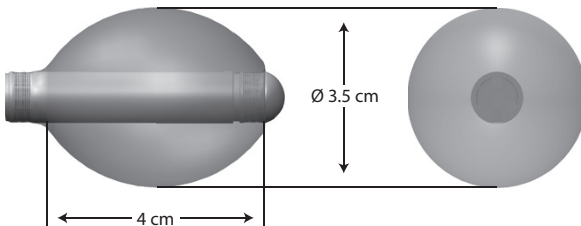

**FIGURE 1. ILLUSTRATION OF MAMMOSITE ML APPLICATOR (INFLATED)**

The MammoSite ML device is available in a variable 3.5–5 cm size.

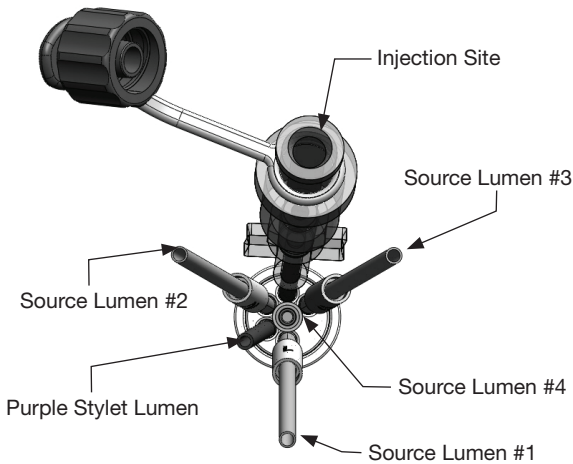

**FIGURE 2. ILLUSTRATION OF MAMMOSITE ML VARIABLE 3.5–5 CM BALLOON (INFLATED)**



**FIGURE 3. ILLUSTRATION OF MAMMOSITE ML VARIABLE 3.5–5 CM BALLOON AT MINIMUM INFLATION VOLUME**

### 3 General Information



**FIGURE 4. ILLUSTRATION OF RADIATION SOURCE LUMENS ON THE MAMMOSITE ML APPLICATOR**

#### **INTENDED USE/INDICATIONS**

The MammoSite ML device is intended to provide brachytherapy when the physician chooses to deliver intracavitary radiation to the surgical margins following lumpectomy for breast cancer.

#### **CONTRAINDICATIONS**

- The MammoSite ML device should not be implanted if the shape and size of the resected tumor cavity is not consistent with the shape and size of the balloon and the fill volume range listed, per balloon size, in Table 1.
- Do not deliver radiation if the minimum distance from the balloon surface to the skin surface is less than 5 mm, or if the distance from the balloon to the skin surface is less than 5 mm over a continuous length greater than 1 cm on the surface of the skin unless the maximum skin dose is less than or equal to 145% of the prescription dose.
- Do not implant the MammoSite ML device in patients with extreme or unusual anatomical features, e.g., extreme rib curves or very unequal amounts of breast tissue around the lumpectomy cavity. This may cause the MammoSite ML applicator to become asymmetrical, thereby affecting the conformal delivery of the radiation dose to the target tissue. Ensure the necessary tissue-to-balloon conformance prior to proceeding with radiation therapy.

**WARNINGS**

**The safety and effectiveness of the MammoSite ML Radiation Therapy System (RTS) as a replacement for whole breast irradiation in the treatment of breast cancer has not been established.**

- No implantable device should be in place for more than 21 days.
- Never fill the system with more fluid than the maximum fill volume listed in Table 1. Overfilling of the balloon could result in rupture of the balloon and/or failure of the device.
- The MammoSite ML device should not be used to deliver radiation if the shape, diameter, and fill volume of the implanted balloon is not consistent with the shapes and diameters in figures 2 and 3 with corresponding diameter and fill volume range noted in Table 1.
- Do not use the MammoSite ML device if any leaks are observed and/or if the balloon does not resemble the approximate size and shape illustrated in Figure 2, per appropriate balloon size.
- Do not implant the MammoSite ML device if the cavity is not visualized by breast imaging technique or if the cavity is too small for the MammoSite ML device implantation. Imaging should verify a minimum distance of 5 mm from balloon surface to skin surface.
- Verify balloon placement and inflation using imaging prior to delivering each brachytherapy fraction. If the balloon diameter changes by greater than 10%, re-evaluate treatment planning prior to delivering a brachytherapy fraction.
- Altering patient position after CT may affect skin spacing, tissue-to-balloon conformance and dose distribution, which may result in an inappropriate patient treatment. Ensure analogous patient positioning from CT through delivery of all fractions.
- Verify treatment parameters per High Dose Rate (HDR) manufacturer's instructions prior to proceeding with radiation therapy.
- Only medical personnel trained and authorized in the safe operation of HDR remote afterloaders should deliver brachytherapy using the MammoSite ML device.
- Do not use excessive force to implant or remove the MammoSite ML device. If the MammoSite ML balloon or shaft becomes bound to the breast tissue, through tissue adhesion, the physician should consider surgical removal.
- For enhanced imaging purposes, the balloon may be filled with a sterile saline/contrast solution not to exceed the maximum fill volume range, per balloon size, listed in Table 1.

## 5 General Information

- This device has been designed for single use only. Reusing this medical device bears the risk of cross-patient contamination as medical devices particularly those with long and small lumina, joints, and/or crevices between components are difficult or impossible to clean once body fluids or tissues with potential pyrogenic or microbial contamination have had contact with the medical device for an indeterminable period of time. The residue of biological material can promote the contamination of the device with pyrogens or microorganisms which may lead to infectious complications.
- For optimal balloon imaging, and to minimize potential radiation dose attenuation, less than 10% contrast per fluid volume is recommended<sup>1</sup>.
- Verify indexed length of all treatment lumens prior to delivery of each brachytherapy fraction. If treatment lumen lengths change by greater than 1 mm, re-evaluate treatment planing prior to delivering a brachytherapy fraction.
- The MammoSite ML should not be used to deliver radiation if the balloon diameter is less than 3.5cm
- For patients who have or may have an allergic reaction to iodinated materials, consider using a non-ionic contrast agent.

### PRECAUTIONS

- The MammoSite ML RTS should be used only by physicians trained in catheter placement, treatment planning and radiation delivery prior to the use of the device.
- Do not use the contents if there is any evidence of damage to the package or package seal that could compromise sterile integrity. Do not resterilize. Single-use device.
- Exercise caution when handling the trocar.
- Keep catheter away from foreign materials at all times. Exercise extreme caution when handling the MammoSite ML balloon prior to and during implantation. Polyurethane materials are susceptible to damage by sharp objects/instruments and excessive pulling or pushing.
- Avoid contact of the product with glove talc, lint, particulate matter, soaps, oils, detergents or other surface contaminants. Caution should be used to avoid contamination of the MammoSite ML device.
- Store product at ambient temperature.
- Use needle-free syringes (provided) when inflating or deflating the MammoSite ML applicator. For proper inflation and deflation, ensure the inflation lumen is not kinked or twisted.

<sup>1</sup>Kassas B, Mourtada F, Horton JL, and Lane RG. Contrast effects on dosimetry of a partial breast irradiation system. *Med Phys.*, 31: 1976-1979, 2004.



- Exercise caution when handling the device to avoid excessive bending of the applicator shaft. Bending or coiling of the shaft to extreme angles could result in kinking of the radiation source pathway(s) and/or failure of the device.
- To avoid possible contamination by foreign particulate do not remove the obturators or stylet from the radiation source lumen during device placement.
- Forceps should not be used during implantation of the balloon. Forceps can damage the balloon.
- During closure of the cavity, both deep and superficial, the balloon must be completely deflated and retracted out of the cavity to avoid needle puncture or abrasions which could lead to deflation of the balloon and/or failure of the device.
- During all levels of closure, suture knots should be rotated away from the lumpectomy cavity to avoid puncture of the balloon by suture ends. When possible, place a layer of breast tissue between the balloon surface and the deepest line of suture to avoid suture abrasion on the balloon which could lead to deflation of the balloon and/or failure of the device.
- Do not use surgical marking clips in conjunction with the MammoSite ML device to avoid puncture of the device.
- The MammoSite ML RTS has only been tested using commercially available Ir<sup>192</sup> HDR sources. It is not recommended for use with HDR equipment other than GammaMed*plus*, Isodose Control, Nucletron and Varian models. It is not compatible with GammaMed® 12(i) afterloaders.
- Ensure that the afterloader transfer tube is fully connected to the desired radiation source lumen of the applicator.
- Always replace the blue luer cap after accessing the needle-free injection site to avoid contamination by foreign particulate and leakage from the injection site.
- The needle-free injection site should only be accessed for applicator inflation and deflation.
- The afterloader connector pathways must be clear and patient movement minimized during radiation treatment to prevent kinking of the applicator.
- In case of balloon deflation/rupture, carefully inspect the device upon removal to ensure that no fragments remain within the lumpectomy cavity.

### HOW SUPPLIED

- The MammoSite ML applicator kit, model ML2345, contains a MammoSite ML applicator, two 30-cc syringes, one 10-cc syringe, one trocar with introducer sheath, one scalpel with #11 knife blade, five

## 7 Instructions for Use

obturator, one rigid stylet, one keyed stylet, one cap and one drainage catheter. An instruction manual and chart stickers are also provided.

- All MammoSite ML applicator trays are supplied in sterile packaging. Each package should be examined carefully prior to opening.

### MAMMOSITE ML DEVICE PLACEMENT PROCEDURE

The MammoSite ML device may be placed using a percutaneous technique up to 10 weeks after lumpectomy. Proper patient selection must be determined by the physician. Patient selection criteria have been set forth by both surgical (American Society of Breast Surgeons) and radiation oncology (American Brachytherapy Society) professional organizations to guide in the appropriate selection of breast brachytherapy candidates<sup>2,3</sup>. Considerations include tumor type, size and histology, nodal status and patient age.

At the time of implant, the balloon size and fill volume that best approximates the cavity should be identified. In addition, imaging should be performed at the time of implant to confirm appropriate tissue-to-balloon conformance and adequate skin spacing.

### MammoSite ML Balloon Selection

Prior to proceeding with MammoSite ML device placement, the appropriate balloon size and fill volume range should be identified. The following guidelines provide direction for choosing appropriate balloon size and fill volume.

1. Identify the balloon size that best approximates the size of the cavity to be implanted, allowing for inflation of the balloon to a volume greater than the cavity to maximize tissue-to-balloon conformance.

When using a variable MammoSite ML device, determine the cavity dimensions (L, W & H).

2. Using Table 1, determine the balloon fill volume that is at least as large as and best fits the cavity to be implanted.

**Table 1. Balloon Fill Volume**

Catalogue Number	Balloon Shape	Balloon Size	Balloon Fill Volume
ML2345	Variable	3.5–4 cm	23–32 cc
	Nominally Spherical	4–5 cm	32–59 cc

<sup>2</sup>Arthur et al. Accelerated partial breast irradiation: an updated report from the American Brachytherapy Society. *Brachytherapy*, 1:184-190,2003.

<sup>3</sup>Revised Consensus statement for accelerated partial breast irradiation. The American Society of Breast Surgeons. Available at <http://www.breastsurgeons.org>

**System Verification**

Immediately prior to the implantation of the MammoSite ML device, complete the following procedure under sterile conditions.

1. Place the MammoSite ML device on a surgical instrument stand or other area clear of all surgical instrumentation.
2. Remove and discard the yellow vent cap.
3. Access the applicator's needle-free injection site with the needle-free syringe and withdraw any air.
4. Use Table 1 to identify the appropriate fluid fill volume range, per balloon size, and fill the syringe with normal sterile fluid solution. Do not exceed the maximum fill volume indicated.
5. Assemble the fluid-filled syringe to the injection site.
6. Slowly inject the sterile fluid solution into the applicator.
7. Repeat steps 3–5, as necessary, to fill the applicator balloon to its required fill volume.
8. Observe the balloon to ensure that it resembles the approximate size and shape illustrated in Figure 2.
9. While continuing to fully depress the syringe, check the balloon, applicator and injection site for any signs of leaks.
10. A small amount of air may be observed within the balloon. This is normal and will not effect treatment planning or delivery.
11. Once it has been determined that the MammoSite ML device is functioning properly, remove all of the fluid from the balloon by withdrawing the plunger of the syringe. Repeat as necessary to ensure all fluid is removed from applicator.

**Applicator Placement**

The placement of the applicator may be accomplished through a variety of techniques. Implantation techniques are at the discretion of the physician.

The following are descriptions of one surgical placement method and one post-surgical placement method for the MammoSite ML applicator using the trocar with introducer sheath. For both placement methods, the obturator in the central lumen may be removed and replaced with the rigid stylet for easier MammoSite ML device insertion.

**Surgical Placement**

1. Place the MammoSite ML device on a surgical instrument stand or other area clear of all surgical instrumentation.

## 9 Instructions for Use

2. Choose an entry point away from the surgical incision. (The physician should select a location for entry that provides the optimum pathway for the applicator/balloon placement into the resected tumor cavity.)
3. To create a pathway for device implantation, make a small nick in the skin using the knife blade included in the MammoSite ML applicator tray.
4. Through the skin nick, advance the trocar with introducer sheath into the surgical cavity.
5. Remove the trocar, leaving the introducer sheath in place.
6. If desired, attach a 30-ml syringe to the drainage catheter and drain any fluids from the cavity by inserting the drainage catheter in the introducer sheath and aspirating. Remove the drainage catheter.
7. Insert the MammoSite ML applicator through the introducer sheath into the cavity. The rigid stylet can be used to aid in the insertion. The rigid stylet can only be used in the central lumen (Source Lumen #4).
8. Remove the introducer sheath.
9. Inflate the balloon with sterile saline/contrast solution to the desired fill volume, per balloon size volume listed in Table 1, to position the balloon in the resected tumor cavity. Remove and discard the yellow vent cap, if attached. Needle-free syringes are provided to allow for solution delivery into the MammoSite ML balloon.
10. Fully deflate the balloon and retract it out of the lumpectomy cavity prior to suturing to avoid balloon puncture or abrasion during closure.
11. Perform closure. It is recommended that suturing be done at a second level 1 cm or more below the surface. The additional line of suture will aid in obtaining the necessary distance between the balloon and the skin surface (> 5 mm). This distance is important to minimize the potential for radiation skin effects. Complete closure using standard surgical suturing of the incision.
12. Position the balloon in the cavity and fully inflate the applicator with sterile saline/contrast solution to the previously determined fill volume. Fluid fill volume may be adjusted, per balloon size fill volume range (Table 1), to achieve desired cavity conformance and skin distance.
13. Recap the needle-free injection site with blue luer cap provided.
14. If the rigid stylet has been used, remove it. Insert an obturator into each of the source lumens and the purple stylet lumen to prevent kinking of the applicator shaft between treatments.
15. Dress the applicator exit site. Avoid kinking the applicator shaft while dressing the site.

16. Record the balloon fill volume on the chart stickers provided in the MammoSite ML applicator box and adhere to the patient's chart.

**Post-Surgical Placement**

1. Locate the lumpectomy cavity, using breast-imaging techniques, e.g., ultrasound.
2. Place the MammoSite ML device on a surgical instrument stand or other area clear of all surgical instrumentation.
3. If a Cavity Evaluation Device (CED) is in place - deflate the CED balloon completely and remove. Determine if local anesthesia is necessary. Then proceed to step 7.
4. Determine the entry point for insertion of the MammoSite ML device.
5. Administer local anesthesia to the trocar entry point and the planned applicator insertion pathway.
6. To create a pathway for device implantation, make a small nick in the skin using the knife blade included in the MammoSite ML applicator tray.
7. Through the skin nick, advance the trocar with introducer sheath into the surgical cavity.
8. Remove the trocar leaving the introducer sheath in place.
9. If desired, attach a 30-ml syringe to the drainage catheter and drain any fluids from the cavity by inserting the drainage catheter through the introducer sheath and aspirating. Remove the drainage catheter.
10. Insert the MammoSite ML applicator through the introducer sheath, using ultrasound guidance, until the tip of the applicator is touching the distal edge of the resected surgical cavity. The rigid stylet can be used to aid in the insertion. The rigid stylet can only be used in the central lumen (Source Lumen #4).
11. Remove the introducer sheath.
12. Inflate the balloon with sterile saline/contrast solution to the desired fill volume, per balloon size volume listed in Table 1, to position the balloon in the resected tumor cavity and confirm applicator placement using ultrasound imaging. Remove and discard the yellow vent cap, if attached. Needle-free syringes are provided to allow for solution delivery into the MammoSite ML balloon. Fluid fill volume may be adjusted per balloon size fill volume range (Table 1) to achieve desired cavity conformance and skin distance.
13. Recap the needle-free injection site with blue luer cap provided.
14. If the stylet has been used, remove it. Insert an obturator into each of the source lumens to prevent kinking of the applicator shaft between treatments.

## 11 Instructions for Use

15. Dress the applicator exit site. Avoid kinking the applicator shaft while dressing the site.
16. Record the balloon fill volume on chart stickers provided in the MammoSite ML applicator box and adhere to the patient's chart.

### USING THE KEYED STYLET

1. Remove the purple cap from the purple stylet lumen.
2. While keeping the applicator as straight as possible - insert the keyed stylet into the purple stylet lumen.
3. There will be a slight tactile sensation when the keyed stylet is engaged.
4. Re-position the applicator by holding the proximal end of the keyed stylet and proximal body of the applicator as desired.
5. Remove the keyed stylet and replace purple cap.
6. Refer to the NOTE in the RADIATION THERAPY DELIVERY section of this manual prior to administration of radiation therapy.

### RADIATION THERAPY DELIVERY

#### Assessment of Balloon Conformance

- Prior to radiation therapy, conformance of the lumpectomy cavity to the balloon surface should be assessed using CT imaging. Ensure the necessary cavity-to-balloon conformance prior to proceeding with radiation therapy.
- Trained medical personnel should review these images. The conformance of the lumpectomy cavity walls to the balloon surface should be analyzed. The conformance of the lumpectomy cavity to the balloon surface should be at least 90% to allow for adequate radiation therapy coverage of the targeted treatment area.
- The MammoSite ML inflation volume may be adjusted to improve the conformance. If adequate conformance cannot be obtained, the MammoSite ML device should not be used for radiation therapy delivery.
- Dosimetry calculations have been made assuming the balloon takes the shape of a sphere and therefore, the device should only be used in lumpectomy cavities that can be made to conform to spherically-shaped balloons.

The radiation oncologist develops a treatment plan designed to deliver a prescribed dose of radiation to the targeted treatment volume. Treatment planning is completed using commercially available planning software and should be based on the shape and inflated size of the implanted MammoSite ML balloon.

Delivery of an optimized radiation dose is readily achievable with the spherical devices using a single dwell position. If desired, multiple dwell positions and multiple lumens may be utilized. Delivery of an optimized radiation dose is readily achievable with the ellipsoidal shape using multiple dwell positions, lumens and times. Ensure that the isodose curves follow the inflated balloon's configuration or shape at the desired prescription point.

Radiation therapy is delivered using a commercially available HDR radiation source. When delivering radiation using HDR remote afterloading, the MammoSite ML applicator connects to the HDR remote afterloader by attaching the HDR afterloader's transfer/guide tube or indexer per manufacturer's instructions to the desired source lumen(s) of the MammoSite ML device. For use with the GammaMed afterloaders, source lumen(s) must be trimmed with appropriate length gauge.

**NOTE:** The MammoSite ML device does not require special fixation to the tissue or skin to maintain its position within the lumpectomy cavity. The expansion of the MammoSite ML balloon fully fills the lumpectomy cavity. Perform the twice daily imaging using CT, x-ray or ultrasound to verify that the MammoSite ML device has not migrated.

In addition, verify that the MammoSite ML positioning markers located on the applicator body are at the same depth. If it appears that the device has migrated, perform imaging to determine the exact positioning of the MammoSite ML device.

In addition to verifying that the MammoSite ML device has not migrated, use twice daily imaging (CT, X-ray or ultrasound) to verify that the balloon diameter has not changed. If the balloon diameter changes by greater than 10%, re-evaluate treatment planning prior to delivering the brachytherapy fraction.

Adhere to the HDR manufacturer's instructions concerning use of the radiation source. It is recommended that a test run be conducted prior to treatment to ensure the source is adequately positioned and functioning properly with the MammoSite ML applicator.

### **MAMMOSITE ML DEVICE REMOVAL PROCEDURE**

Once the radiation therapy is completed, withdraw all fluid residing in the MammoSite ML balloon and carefully remove the applicator. Caution should be exercised when removing the MammoSite ML device from the resection cavity. Dispose of the MammoSite ML device as medical waste.

## 13 For More Information and Warranty

### FOR MORE INFORMATION

For technical support or reorder information in the United States, please contact:



Hologic, Inc.  
250 Campus Drive  
Marlborough, MA 01752 USA  
Phone: 877-371-4372  
[www.hologic.com](http://www.hologic.com)

### WARRANTY

Except as otherwise expressly stated in the Agreement: i) Equipment manufactured by Hologic is warranted to the original Customer to perform substantially in accordance with published product specifications for one (1) year starting from the date of shipment, or if Installation is required, from the date of Installation (“Warranty Period”); ii) digital imaging mammography x-ray tubes are warranted for twenty-four (24) months, during which the x-ray tubes are fully warranted for the first twelve (12) months and are warranted on a straight-line prorated basis during months 13-24; iii) replacement parts and remanufactured items are warranted for the remainder of the Warranty Period or ninety (90) days from shipment, whichever is longer; iv) consumable Supplies are warranted to conform to published specifications for a period ending on the expiration date shown on their respective packages; v) licensed Software is warranted to operate in accordance with published specifications; vi) Services are warranted to be supplied in a workman-like manner; vii) non-Hologic Manufactured Equipment is warranted through its manufacturer and such manufacturer’s warranties shall extend to Hologic’s customers, to the extent permitted by the manufacturer of such non-Hologic Manufactured Equipment. Hologic does not warrant that use of Products will be uninterrupted or error-free, or that Products will operate with non-Hologic authorized third-party products.









Hologic, Inc.  
250 Campus Drive  
Marlborough, MA 01752 USA  
Phone (877) 371-4372  
[www.hologic.com](http://www.hologic.com)

Hologic, MammoSite, MammoSite ML and associated logos are trademarks and/or registered trademarks of Hologic, Inc. and/or its subsidiaries in the United States and/or other countries.

Flexitron is a registered trademark of Isodoset Controls. Varian and VariSource are trademarks or registered trademarks of Varian Medical Systems Technologies. Nucletron is a registered trademark of Nucletron Corporation. GammaMed is a registered trademark of Varian Medical Systems HAAN GMBH Corporation.

Patent: <http://hologic.com/patentinformation>  
© 2015-2019, Hologic, Inc.

**HOLOGIC®**