

DICOM Conformance Statement
Advanced Workflow Manager
MAN-10608 Revision 001

Selenia[®] Dimensions[®] 3Dimensions[™]

Advanced Workflow Manager

DICOM Conformance Statement

For Software Version 1.10

Part Number MAN-10608

Revision 001

August 2023

Technical Support

USA: +1.877.371.4372

Asia: +852 37487700

Europe: +32 2 711 4690

Australia: +1 800 264 073

All Other: +1 781 999 7750

Email: BreastHealth.Support@hologic.com

© 2023 Hologic, Inc. Printed in the USA. This manual was originally written in English.

Hologic, Selenia, Dimensions, 3Dimensions, and associated logos are trademarks and/or registered trademarks of Hologic, Inc., and/or its subsidiaries in the United States and/or other countries. All other trademarks, registered trademarks, and product names are the property of their respective owners.

This product may be protected by one or more U.S. or foreign patents as identified at www.Hologic.com/patents.



Hologic, Inc.
600 Technology Drive
Newark, DE 19702 USA
1.800.447.1856

Brazilian Contact:
Imex Medical Group do Brasil
Rua das Embaúbas, 601- Fazenda Santo Antônio
São José /SC - Brasil - 88104-561
+55 48 3251-8800
www.imexmedicalgroup.com.br

HOLOGIC[®]

Table of Contents

1.0 Overview	4
2.0 Introduction	5
2.1 Audience	5
2.2 Remarks	5
2.3 Definitions, Terms and Abbreviations	6
2.4 References	6
3.0 Networking	7
3.1 Implementation Model	7
3.1.1 Application Data Flow	7
3.1.2 Functional Definition of AE's	8
3.1.3 Sequencing of Real World Activities	8
3.2 AE Specifications	9
3.2.1 Retrieve Client AE	9
3.2.2 Storage Server AE	11
3.2.3 Verification Client AE	14
3.3 Network Interfaces	15
3.3.1 Physical Network Interface	15
3.3.2 Additional Protocols	15
3.4 Configuration	16
3.4.1 AE Title/Presentation Address Mapping	16
3.4.2 Configuration Parameters for Local AEs	17
4.0 Media Interchange	18
5.0 Support of Character Sets	18
6.0 Security	18
7.0 Annexes	19
7.1 IOD Contents	19
7.1.1 Usage of Attributes from Received IODs	19
7.1.2 Coerced/Modified Attributes	19
7.2 Data Dictionary of Private Attributes	19
7.3 Coded Terminology and Templates	19
7.4 Grayscale Image Consistency	19
7.5 Standard Extended/Specialized/Private SOP Classes	19
7.6 Private Transfer Syntaxes	19

1.0 Overview

The Hologic® Advanced Workflow Manager implements the necessary DICOM services to:

- Retrieve Hologic Digital Mammography X-Ray Image – For Processing and/or Breast Projection X-Ray Image Storage – For Processing, any DICOM conformant Digital Mammography X-Ray Image - For Presentation, Breast Projection X-Ray Image Storage – For Presentation, Breast Tomosynthesis Image Storage and/or Secondary Capture Image, Hologic 3D Mammography™ Raw Projections, Processed Projections, Reconstructed Slices and any DICOM conformant Grayscale Softcopy Presentation State objects from a networked storage device.
- Store Hologic Digital Mammography X-Ray Image - For Processing and/or Breast Projection X-Ray Image Storage – For Processing, any DICOM conformant Digital Mammography X-Ray Image - For Presentation, Breast Projection X-Ray Image Storage – For Presentation, Breast Tomosynthesis Image Storage and/or Secondary Capture Image, Hologic 3D Mammography Raw Projections, Processed Projections, Reconstructed Slices, and any DICOM conformant Grayscale Softcopy Presentation State objects received from an external device.



Note

Receiving and storing Reconstructed Slices as CT Image Storage, Mammography CAD SR Storage and X-Ray Radiation Dose SR Storage are not supported.

Table 1-1 provides an overview of the network services supported by the Advanced Workflow Manager.

Table 1-1
NETWORK SERVICES

SOP Classes	User of Service (SCU)	Provider of Service (SCP)
Transfer		
Digital Mammography X-Ray Image Storage – For Presentation	No	Yes
Digital Mammography X-Ray Image Storage – For Processing	No	Yes
Secondary Capture Image Storage	No	Yes
Breast Tomosynthesis Image Storage	No	Yes
Breast Projection X-Ray Image Storage – For Processing	No	Yes
Breast Projection X-Ray Image Storage – For Presentation	No	Yes
Grayscale Softcopy Presentation State Storage	No	Yes
Retrieve		
Study Root Query/Retrieve Information Model – MOVE	Option	No

2.0 Introduction

Hologic, Inc. develops and markets a full line of mammography products including the family of Selenia Dimensions full-field digital mammography systems with the Hologic 3D Mammography option and their Acquisition Workstations. The Advanced Workflow Manager (AWM) enhances the workflow between multiple Acquisition Workstations within a local area network that are configured within an Advanced Workflow Manager cluster.

2.1 Audience

This document contains the DICOM conformance claim for the Advanced Workflow Manager. This document is intended to aid in connecting the Advanced Workflow Manager to other components that make use of the DICOM standard for interconnecting networked imaging devices.

The information within this document applies to Advanced Workflow Manager Software version 1.10. The reader of this document should be familiar with the DICOM standard and PACS components that utilize the standard.

2.2 Remarks

A DICOM conformance statement, the structure and content of which are stipulated by the DICOM standard, is intended to aid in determining the suitability of interconnecting digital imaging devices. References to specific functionality in a conformance statement are not sufficient to guarantee interoperability between components. The following should be considered when evaluating interoperability:

- The Advanced Workflow Manager conformance statement provides a starting point for ascertaining whether the product can communicate with other systems.
- The only way to know for certain whether the Advanced Workflow Manager can interoperate with other systems is to perform connectivity testing.
- This document represents a best effort to document the functionality of commercial versions of the Advanced Workflow Manager and is not a functional specification of any Hologic component or product. Hologic reserves the right to make changes at any time to the functionality of the DICOM components described herein, and is committed to following the evolution of the DICOM standard.

2.3 Definitions, Terms and Abbreviations

ACR: American College of Radiology

AE: Application Entity

AWM: Advanced Workflow Manager

DICOM: Digital Imaging and Communications in Medicine

DIMSE: DICOM Message Service Element

Generated 2D: Synthesized 2D digital image generated from Hologic 3D Mammography data

GSPS: Grayscale Softcopy Presentation State

IOD: Information Object Definition

JPEG: Joint Photographic Experts Group (data compression techniques)

NEMA: National Electrical Manufacturers Association

PACS: Picture Archive and Communications System (image management and long-term storage)

PDU: Protocol Data Unit

SCP: Service Class Provider

SCU: Service Class User

SOP: Service Object Pair

TCP/IP: Transmission Control Protocol/Internet Protocol

UID: Unique Identifier

2.4 References

- NEMA PS3 / ISO 12052, Digital Imaging and Communications in Medicine (DICOM) Standard, National Electrical Manufacturers Association, Rosslyn, VA, USA (available free at <https://www.dicomstandard.org/>)

3.0 Networking

3.1 Implementation Model

3.1.1 Application Data Flow

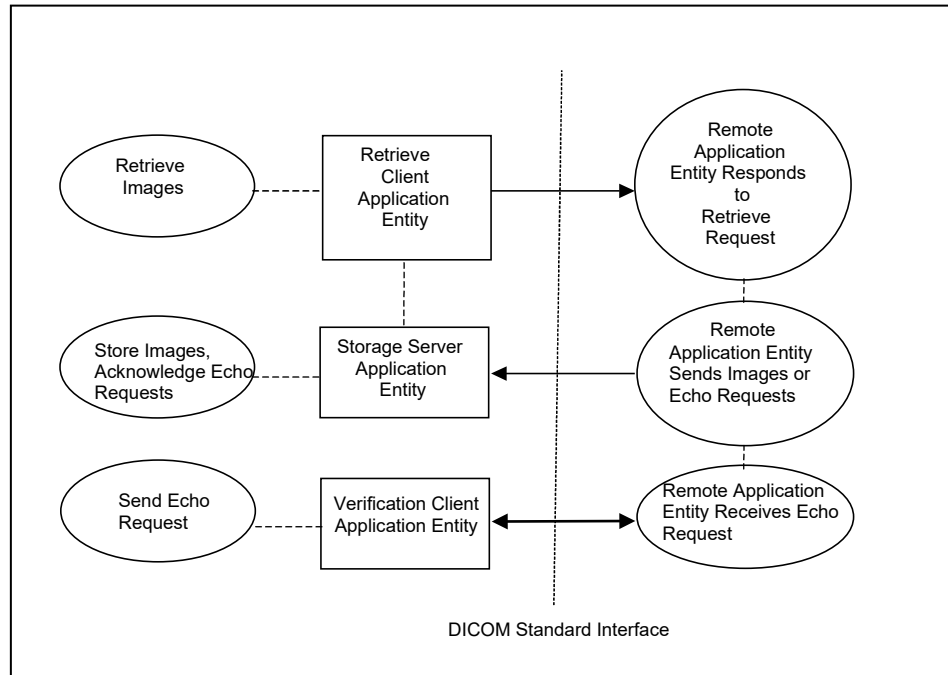

- The Retrieve Client Application Entity retrieves images. “Retrieve Images” is performed upon the Advanced Workflow Manager receiving a DICOM conformant Grayscale Softcopy Presentation State object whose Study Instance UID is not in the Advanced Workflow Manager database. The Retrieve Client requests a remote AE for the corresponding study making the objects of the study accessible to Acquisition Workstations within the Advanced Workflow Manager cluster.
- The Storage Server Application Entity receives echo requests, images, and/or GSPS objects from a remote AE. The Storage Server Application Entity is available whenever the Advanced Workflow Manager application is running.
- The Verification Client Application Entity sends an echo request to a remote AE. The Verification Client Application Entity is available as part of the Advanced Workflow Manager Service Tool utility.

3.1.2 Functional Definition of AE's

Multiple local Application Entities may be active simultaneously.

3.1.2.1 Functional Definition of Retrieve Client Application Entity

The Retrieve Client AE is activated when the Advanced Workflow Manager receives a Grayscale Softcopy Presentation State object whose Study Instance UID is not in its database. An association request is sent to the remote AE and upon successful negotiation, a retrieve request is sent to the remote AE. The Storage Server AE is active whenever the application is running and will receive the study. If an association cannot be opened or retrieve request fails, an error is generated and the retrieve job is deleted.

3.1.2.2 Functional Definition of Storage Server Application Entity

The Storage Server AE is active (i.e., listen port is active) to accept echo and storage requests whenever the Advanced Workflow Manager application is running. The received Instances are stored to a temporary directory and then imported to the database.

3.1.2.3 Functional Definition of Verification Client Application Entity

The Verification Client AE is available to the user as a DICOM troubleshooting tool in the Service Tool utility. It is available to test all remote SCP devices.

3.1.3 Sequencing of Real World Activities

The Advanced Workflow Manager (AWM) enhances workflow among Acquisition Workstations within its local area network cluster by tracking and providing access to received images and related information to all Acquisition Workstations within a cluster.

The AWM will also retrieve a study from a remote AE upon receiving a Grayscale Softcopy Presentation State object whose Study Instance UID is not in the AWM database.

In cases where error(s) occur during transmission, the affected job(s) will be retried if the error condition is temporary; otherwise it will be stopped.

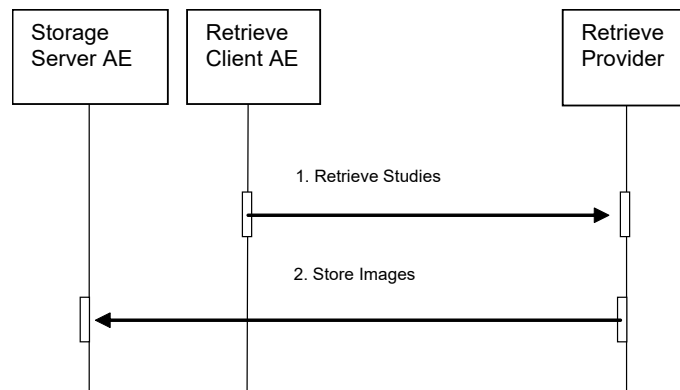

Figure 3.1-1: Retrieve Sequence Diagram

A Storage Client AE initiates a DICOM store request to the AWM Storage Server AE. The AWM accepts the request and receives the studies/images sent by the Storage Client AE, via the Storage Server AE.

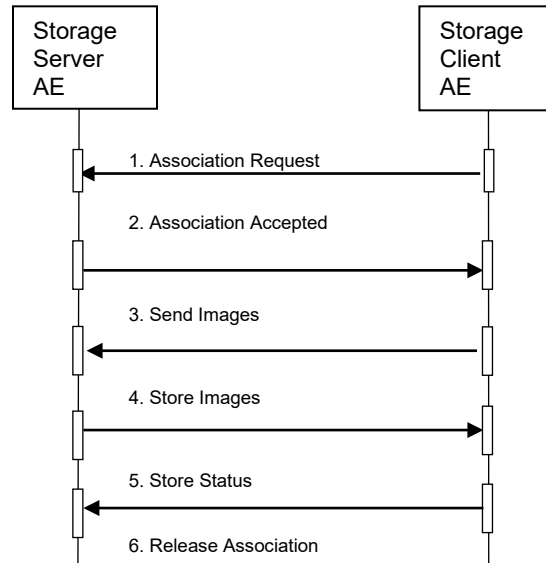

Figure 3.1-2: Storage Sequence Diagram

3.2 AE Specifications

3.2.1 Retrieve Client AE

3.2.1.1 SOP Classes

This Application Entity provides Standard Conformance to the following SOP Classes:

Table 3.2.1-1

SOP CLASSES FOR RETRIEVE CLIENT AE

SOP Class Name	SOP Class UID	SCU	SCP
Study Root Query/Retrieve Information Model – MOVE	1.2.840.10008.5.1.4.1.2.2.2	Yes	No

3.2.1.2 Association Policies

3.2.1.2.1 General

The DICOM standard Application context shall be specified.

Table 3.2.1-2

DICOM APPLICATION CONTEXT

Application Context Name	1.2.840.10008.3.1.1.1
--------------------------	-----------------------

3.2.1.2.2 Number of Associations

One association is initiated at a time for the Retrieve Client AE.

3.2.1.2.3 Asynchronous Nature

The Advanced Workflow Manager does not support asynchronous operations (multiple outstanding transactions over a single Association).

3.2.1.2.4 Implementation Identifying Information

Table 3.2.1-3

DICOM IMPLEMENTATION CLASS AND VERSION FOR RETRIEVE CLIENT

Implementation Class UID	1.2.840.114089.1.0.0.3.3.12
Implementation Version Name	DCF 3.3.12c

3.2.1.3 Association Initiation Policy

3.2.1.3.1 Retrieve Images

3.2.1.3.1.1 Description and Sequencing of Activities

The Retrieve Client attempts to establish an association with a remote Retrieve AE upon receiving a Grayscale Softcopy Presentation State object whose Study Instance UID is not in its database. A C-MOVE is requested to a remote Retrieve AE. The Retrieve Client releases the association after receiving the final C-MOVE response from the remote Retrieve AE.

3.2.1.3.1.2 Proposed Presentation Contexts

The Retrieve Client attempts to establish associations using the following presentation contexts:

Table 3.2.1-4

PROPOSED PRESENTATION CONTEXTS FOR RETRIEVE IMAGES

Presentation Context Table					
Abstract Syntax		Transfer Syntax		Role	Extended
Name	UID	Name List	UID List		Negotiation
Study Root Query/Retrieve Information Model – MOVE	1.2.840.10008.5.1.4.1.2.2.2	Implicit VR, Little Endian	1.2.840.10008.1.2	SCU	None
		Explicit VR, Little Endian	1.2.840.10008.1.2.1		

3.2.1.3.1.3 SOP Specific Conformance for Retrieve

The behavior of the Advanced Workflow Manager when encountering status codes in a C-MOVE response is summarized in the Table below.

Table 3.2.1-5

C-MOVE RESPONSE STATUS HANDLING BEHAVIOR

Service Status	Further Meaning	Error Code	Behavior
Success	Matching or sub-operations are complete	0000	The SCP has successfully completed all sub-operations.
Warning or Failure	Any	Any	AE aborts association.

The behavior of the Advanced Workflow Manager during communication failure is summarized in the Table below.

Table 3.2.1-6
C-MOVE COMMUNICATION FAILURE BEHAVIOR

Exception	Behavior
Timeout	The Association is aborted and an error message is logged: "Retrieve not acknowledged in the allotted time."
Association aborted by SCP	When an Association is aborted for a C-MOVE, an error is logged: "There were error(s) when pulling back the image(s): Cannot open socket to specified host/port, a network error has occurred, or received abort from remote system."

The Retrieve Client provides standard conformance to the Study Root Information Model. The hierarchical method is used. A Study level move request is sent, containing the Study Instance UID of the study to retrieve.

3.2.1.4 Association Acceptance Policy

The Retrieve Client AE does not accept associations.

3.2.2 Storage Server AE

3.2.2.1 SOP Classes

This Application Entity provides Standard Conformance to the following SOP Classes:

Table 3.2.2-1
SOP CLASSES FOR STORAGE SERVER AE

SOP Class Name	SOP Class UID	SCU	SCP
Digital Mammography X-Ray Image Storage – For Presentation	1.2.840.10008.5.1.4.1.1.1.2	No	Yes
Digital Mammography X-Ray Image Storage – For Processing	1.2.840.10008.5.1.4.1.1.1.2.1	No	Yes
Breast Tomosynthesis Image Storage	1.2.840.10008.5.1.4.1.1.13.1.3	No	Yes
Breast Projection X-Ray Image Storage – For Presentation	1.2.840.10008.5.1.4.1.1.13.1.4	No	Yes
Breast Projection X-Ray Image Storage – For Processing	1.2.840.10008.5.1.4.1.1.13.1.5	No	Yes
Secondary Capture Image Storage	1.2.840.10008.5.1.4.1.1.7	No	Yes
Grayscale Softcopy Presentation State Storage	1.2.840.10008.5.1.4.1.1.11.1	No	Yes
Verification SOP Class	1.2.840.10008.1.1	No	Yes

3.2.2.2 Association Policies

3.2.2.2.1 General

The DICOM standard Application context shall be specified.

Table 3.2.2-2
DICOM APPLICATION CONTEXT

Application Context Name	1.2.840.10008.3.1.1.1
--------------------------	-----------------------

3.2.2.2.2 Number of Associations

One association is accepted at a time for the Storage Server AE.

3.2.2.2.3 Asynchronous Nature

The Advanced Workflow Manager does not support asynchronous operations (multiple outstanding transactions over a single Association).

3.2.2.2.4 Implementation Identifying Information

Table 3.2.2-3

DICOM IMPLEMENTATION CLASS AND VERSION FOR STORAGE SERVER

Implementation Class UID	1.2.840.114089.1.0.0.3.3.12
Implementation Version Name	DCF 3.3.12c

3.2.2.3 Association Initiation Policy

The Storage Server AE does not initiate associations.

3.2.2.4 Association Acceptance Policy

When the Storage Server AE accepts an association, it will respond to storage and echo requests.

3.2.2.4.1 Activity – Receive Images

3.2.2.4.1.1 Description and Sequencing of Activities

The Storage Server AE starts upon launching the AWM application. The Storage Server AE stores images and GSPS objects that are received so they can be made available to Acquisition Workstations within the AWM cluster. When the AWM application receives a request to shutdown, the Storage Server AE stops running after the configurable time (in seconds) assigned to the Shutdown Wait Seconds parameter has elapsed. As a default, if a received Instance is a duplicate of an existing stored Instance, the received Instance is ignored, and the AWM sends a status of storage success in the C-STORE-RSP. However, the Storage Server AE can be configured to delete the first imported Instance of a stored object and import the duplicate Instance of the stored object.

3.2.2.4.1.2 Accepted Presentation Contexts

The Storage Server accepts associations using the following presentation contexts. Note: Implicit VR Little Endian is the Transfer Syntax AWM will accept as a default when more than one transfer syntax is proposed within a presentation context.

Table 3.2.2-4
**ACCEPTABLE PRESENTATION CONTEXTS FOR
STORAGE SERVER AND RECEIVE IMAGES**

Presentation Context Table					
Abstract Syntax		Transfer Syntax		Role	Extended Negotiation
Name	UID	Name List	UID List		
Digital Mammography X-Ray Image Storage – For Presentation	1.2.840.10008.5.1.4.1.1.1.2	See Table 3.2.2-5		SCP	None
Digital Mammography X-Ray Image Storage – For Processing	1.2.840.10008.5.1.4.1.1.1.2.1	See Table 3.2.2-5		SCP	None
Secondary Capture Image Storage	1.2.840.10008.5.1.4.1.1.7	See Table 3.2.2-5		SCP	None
Breast Tomosynthesis Image Storage	1.2.840.10008.5.1.4.1.1.13.1.3	See Table 3.2.2-5		SCP	None
Breast Projection Image Storage – For Presentation	1.2.840.10008.5.1.4.1.1.13.1.4	See Table 3.2.2-5		SCP	None
Breast Projection Image Storage – For Processing	1.2.840.10008.5.1.4.1.1.13.1.5	See Table 3.2.2-5		SCP	None
Grayscale Softcopy Presentation State Storage	1.2.840.10008.5.1.4.1.1.11.1	Implicit VR, Little Endian	1.2.840.10008.1.2	SCP	None
		Explicit VR Little Endian	1.2.840.10008.1.2.1		
		Explicit VR Big Endian	1.2.840.10008.1.2.2		
Verification SOP Class	1.2.840.10008.1.1	Implicit VR, Little Endian	1.2.840.10008.1.2	SCP	None
		Explicit VR Little Endian	1.2.840.10008.1.2.1		
		Explicit VR Big Endian	1.2.840.10008.1.2.2		

Table 3.2.2-5
ACCEPTABLE TRANSFER SYNTAXES FOR STORAGE SERVER AND RECEIVE IMAGES

Transfer Syntax Table	
Name	UID
JPEG Lossless, Non-Hierarchical, First-Order Prediction (Process 14 [Selection Value 1])	1.2.840.10008.1.2.4.70
Explicit VR Little Endian	1.2.840.10008.1.2.1
Implicit VR Little Endian	1.2.840.10008.1.2
Explicit VR Big Endian	1.2.840.10008.1.2.2
JPEG 2000 Image Compression (Lossless Only)	1.2.840.10008.1.2.4.90

3.2.2.4.1.3 SOP Specific Conformance for Storage SOP Classes

The Storage Server AE provides standard conformance to the Storage and Verification Service Classes.

The AWM will store any DICOM conformant Grayscale Softcopy Presentation State objects.

The Storage Server AE will behave as described in the Table below when generating the C-STORE response.

Table 3.2.2-6
STORAGE C-STORE RESPONSE STATUS

Service Status	Further Meaning	Error Code	Reason
Success	Success	0000	Image is stored locally and made available to Acquisition Workstations in the cluster.
Failure	Processing failure	0110	There is not enough local storage capacity to store the image. Error Comment (0000,0902) is sent.

3.2.3 Verification Client AE

3.2.3.1 SOP Classes

This Application Entity provides Standard Conformance to the following SOP Class:

Table 3.2.3-1
SOP CLASS FOR VERIFICATION CLIENT AE

SOP Class Name	SOP Class UID	SCU	SCP
Verification SOP Class	1.2.840.10008.1.1	Yes	No

3.2.3.2 Association Policies

3.2.3.2.1 General

The DICOM standard Application context shall be specified.

Table 3.2.3-2
DICOM APPLICATION CONTEXT

Application Context Name	1.2.840.10008.3.1.1.1
--------------------------	-----------------------

3.2.3.2.2 Number of Associations

One association is initiated at a time for the Verification Client AE.

3.2.3.2.3 Asynchronous Nature

The Advanced Workflow Manager does not support asynchronous operations (multiple outstanding transactions over a single Association).

3.2.3.2.4 Implementation Identifying Information

Table 3.2.3-3
DICOM IMPLEMENTATION CLASS AND VERSION FOR VERIFICATION CLIENT

Implementation Class UID	1.2.840.114089.1.0.0.3.3.12
Implementation Version Name	DCF 3.3.12c

3.2.3.3 Association Initiation Policy

3.2.3.3.1 Activity - Echo Request

3.2.3.3.1.1 Description and Sequencing of Activities

The Advanced Workflow Manager provides the user with the capability to C-ECHO any remote Service Class Provider configured on the system as a virtual device.

3.2.3.3.1.2 Proposed Presentation Contexts

The Verification Client attempts to establish associations using the following Presentation Contexts.

Table 3.2.3-4
PROPOSED PRESENTATION CONTEXTS FOR ECHO REQUEST

Presentation Context Table					
Abstract Syntax		Transfer Syntax		Role	Extended Negotiation
Name	UID	Name	UID		
Verification SOP Class	1.2.840.10008.1.1	Implicit VR, Little Endian	1.2.840.10008.1.2	SCU	None

3.2.3.3.1.3 SOP Specific Conformance for Verification SOP Class

Verification Client provides standard conformance to the Verification Service Class. The behavior of the Advanced Workflow Manager when encountering status codes in a C-ECHO response is summarized in the Table below.

Table 3.2.3-5
VERIFICATION C_ECHO RESPONSE STATUS HANDLING BEHAVIOR

Service Status	Further Meaning	Error Code	Behavior
Success	Success	0000	Indicate a status of success to the user.
Failure	Any	Any	Indicate a status of failure to the user.

3.2.3.4 Association Acceptance Policy

The Verification Client AE does not accept associations.

3.3 Network Interfaces

3.3.1 Physical Network Interface

The Advanced Workflow Manager is tested and supports using 10-BaseT, 100-BaseT and 1000-BaseT Ethernet media.

3.3.2 Additional Protocols

None.

3.4 Configuration

The DICOM Retrieve Client is configured during site installation.

A Verification Client, used primarily as a troubleshooting tool, is made available through a service tool utility. It attempts to establish an association with a remote Verification SCP when invoked by a service tool utility.

The Storage Server acts as a Verification SCP. It accepts associations from any remote AE Title.

3.4.1 AE Title/Presentation Address Mapping

3.4.1.1 Local AE Titles

Table 3.4-1
AE TITLE CONFIGURATION TABLE

Application Entity	Default AE Title	Default TCP/IP Port
Retrieve Client	DIRECT_DIGXRAY	N/A
Local Storage Server	DIRECT_DIGXRAY	104
Verification Client	DIRECT_DIGXRAY	N/A

The default AE Title and TCP/IP Port number may be modified.

3.4.1.2 Remote AE Title/Presentation Address Mapping

3.4.1.2.1 Remote Retrieve SCP

The following are some of the relevant configurable items for the Remote Retrieve SCP:

Table 3.4-2
REMOTE RETRIEVE SCP CONFIGURATION

Parameter description	Range
Application Entity Title (Called AE)	The Advanced Workflow Manager supports one AE acting as a Retrieve provider.
Remote Host/IP Address	IP address and hostname associated with the Retrieve provider AE.
Port Number	Port number to use when establishing TCP/IP connection to the Retrieve provider AE. Range = 1 to 65,535
Transfer Syntax	<ul style="list-style-type: none"> • Implicit VR Little Endian or • Explicit VR Little Endian or • Explicit VR Big Endian
Information Model	<ul style="list-style-type: none"> • Study Root

3.4.2 Configuration Parameters for Local AEs

The following are some of the relevant configurable items for the local AEs:

Table 3.4-3
CONFIGURATION PARAMETERS

Parameter	Configurable (Yes/No)	Default Value
Number of seconds to wait for response to TCP/IP connect request (operating system controlled)	No	~220
ACSE PDU read timeout: Number of seconds to wait for response to an Association Open or Close Request.	Yes	30
ARTIM timeout: Number of seconds for acting SCP to wait from socket accept until Association request is read	Yes	30
Association Idle Timeout: Number of seconds of idle time allowed before an acting SCP automatically terminates an association. The idle timer runs until a complete DIMSE message is received.	Yes	180
Maximum PDU size the AE can receive	Yes, per local SCU	32,768
Maximum PDU size the AE can send (used if not negotiated). Range = 1,024 to 65,535	Yes, per local SCU	32,768
Retrieve Client		
C-MOVE Timeout: Number of seconds to wait for C-MOVE response	Yes	600
Storage Server		
Host: The IP address of the Storage Server. When it is set to 0.0.0.0 the system default IP will be used.	Yes	0.0.0.0
AE Title: The AE Title of the Storage Server	Yes	DIRECT_DIGXRAY
TCP port: Port on which the Advanced Workflow Manager Association Manager listens.	Yes	104
Maximum Concurrent Associations	Yes	8
AE Title Case Sensitive	Yes	No
Duplicate UID: determines how a duplicate SOP Instance is handled	Yes	Ignore

4.0 Media Interchange

N/A

5.0 Support of Character Sets

The Advanced Workflow Manager supports the following character sets for the values of Data Elements with a VR of SH, LO, ST, PN or LT:

- Default:ISO-IR 6
- Latin Alphabet No. 1: ISO-IR 100

6.0 Security

The Advanced Workflow Manager does not support any specific DICOM security measures.

It is assumed that the AWM is used within a secured environment. It is assumed that a secured environment includes at a minimum:

- Firewall or router protections to ensure that only approved external hosts have network access to the AWM.
- Firewall or router protections to ensure that the AWM only has network access to approved external hosts and services.
- Any communication with external hosts and services outside the locally secured environment use appropriate secure network channels (e.g. such as a Virtual Private Network (VPN)).
- Other network security procedures such as automated intrusion detection may be appropriate in some environments. Additional security features may be established by the local security policy and are beyond the scope of this conformance statement.

7.0 Annexes

7.1 IOD Contents

N/A

7.1.1 Usage of Attributes from Received IODs

The following attributes are required to be present with a non-zero length value for successful interpretation of received Digital Mammography X-Ray Image SOP Instances:

- (0008,0016) SOP Class UID: one of the supported values
- (0008,0068) Presentation Intent Type
- (0008,1030) Study Description
- (0010,0020) Patient ID
- (0020,0011) Series Number
- (0020,0013) Instance Number
- (0028,0010) Rows
- (0028,0011) Columns
- At least one of the following:
 - (0008,0050) Accession Number
 - (0020,0010) Study ID
 - (0040,1001) Requested Procedure ID
- At least one attribute that identifies the mammography view

7.1.2 Coerced/Modified Attributes

The Advanced Workflow Manager can be configured to add, edit, or remove specific attributes in received SOP Instances. By default, the AWM will attempt to add missing attributes that are required for interpretation by the Acquisition Workstation display module, such as the Private Attributes (0019) of Hologic Digital Mammography X-Ray images.

7.2. Data Dictionary of Private Attributes

N/A

7.3. Coded Terminology and Templates

N/A

7.4. Grayscale Image Consistency

N/A

7.5. Standard Extended/Specialized/Private SOP Classes

N/A

7.6. Private Transfer Syntaxes

N/A