

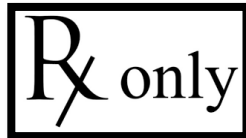

## USER'S GUIDE



**CAUTION:** Federal Law (U.S.) restricts this device to sale by or on the order of a physician trained in the use of the Acessa ProVu System for ablation of symptomatic uterine fibroids

1.	Introduction	3	10.14.	Shutting Down the System	19
2.	Indications For Use	3	11.	Special Considerations: General Ablation Procedures	20
3.	Device Description and Components	3	11.1.	Highly Vascularized Tissue	20
4.	Contraindications	5	11.2.	One or More Electrode Arrays in a Duct or Vessel	20
5.	Warnings	5	11.3.	Ablation of Dense or Calcified Fibroid Tissue	20
5.1.	General Warnings	5	12.	Ex-Vivo Studies	20
5.2.	Environmental and EMI Warnings	6	12.1.	Ex-Vivo Studies	20
5.3.	Warnings During Electrosurgical Device Use	7	12.2.	Representative Ablation Shape per Deployment	20
5.4.	Warnings Specific to the Acessa ProVu System	7	12.3.	Results from Ex-Vivo Bovine Liver Studies	21
5.5.	Warnings Concerning Acessa ProVu System Guidance Accuracy	7	12.4.	Representative Ablation Sizes in Ex-vivo Bovine Liver with Settings in Temperature Control	21
5.6.	Warnings Specific to Uterine Fibroid Ablation	7	13.	Clinical Studies – Fibroids	21
6.	Precautions	8	13.1.	Study Design	22
6.1.	General Precautions	8	13.2.	Study Objectives	22
6.2.	Environmental and EMI Precautions	8	13.2.1.	Primary Objectives	22
6.3.	Precautions During Electrosurgical Device Use	8	13.2.2.	Secondary Objectives	22
6.4.	Precautions Specific to the Acessa ProVu System	8	13.2.3.	Inclusion and Exclusion Criteria	22
6.5.	Precautions Concerning Acessa ProVu System Guidance Accuracy	8	13.3.	Study Demographics	22
6.6.	Precautions Specific to Uterine Fibroid Ablation	8	13.4.	Fibroid Symptoms and Characteristics Reported at Baseline – All Subjects	23
7.	Sterilization and Safety Checks	9	13.5.	Treatment	23
8.	Switches, Buttons, Connections, and Display	9	13.6.	Results of the Pivotal Study	24
8.1.	Front Panel	9	13.7.	Safety	24
8.2.	Buttons, Connections and Display	9	13.8.	Efficacy	25
8.3.	Rear Panel	10	13.9.	Surgical Reintervention Rate	25
8.4.	Switches and Connections	10	13.10.	Uterine and Fibroid Volume	25
9.	Setting up the Acessa ProVu System	11	13.11.	UFS-QOL Scores	26
9.1.	Connecting System Components	11	13.12.	EQ-5D Health State Score	27
9.2.	Before Patient Arrives	11	13.13.	Overall Treatment Effect (OTE) Survey	27
9.3.	Patient Preparation	11	13.14.	Data regarding return to work and return to normal activities	27
9.4.	Energizing The System	12	13.15.	Data regarding pregnancy	27
10.	Use of the Acessa System	12	13.16.	Data regarding calcified fibroids	27
10.1.	Getting Ready	12	13.17.	Therapeutic medications at 24 and 36 months post-treatment	27
10.2.	Accessory Connections	13	14.	Postmarket Surveillance Study – TRUST (Treatment Results of Uterine Sparing Technologies)	28
10.3.	User Interface	14	14.1.	Summary of the Post-Approval Study Methods	28
10.4.	Menu Settings	15	14.1.1.	Study Objective	28
10.5.	Ultrasound Settings	15	14.1.2.	Study Design	28
10.6.	Expected Ablation Size	15	14.1.3.	Study Population	28
10.7.	Deployment, Ablation and Coag	15	14.1.4.	Data Source	28
10.8.	Pad Temperatures	16	14.2.	Key Study Endpoints	28
10.9.	The Acessa ProVu Guidance System Feature	16	14.2.1.	Primary Endpoint	28
10.10.	Procedure Planning	18	14.2.2.	Secondary Endpoint	28
10.11.	Performing an Ablation	18	14.3.	Total Number of Enrolled Study Sites	28
10.12.	Operation of System During Coag	19			
10.13.	After the Procedure	19			

---

14.4.	Total Number of Enrolled Subjects and Follow-up Rate	28	18.1.	System Specifications	31
14.5.	Study visits and length of follow up	28	18.2.	Guidance and Manufacturer's Declaration	32
14.6.	Summary of the Post-Approval Study Results	29	18.3.	Technical Characteristics	35
14.6.1.	Final safety findings (key endpoints)	29	18.4.	Compliance to Safety and Performance Standards	36
14.6.2.	Study Strengths and Weaknesses	30	19.	Trouble Shooting	36
15.	Potential Risks of Acessa ProVu System	30	19.1.	Faults, Alerts, and Errors	36
16.	Patient Counseling	31	19.2.	Fault/Alert Code Table	36
17.	Care and Maintenance	31	20.	Glossary of Symbols and Product Graphics	39
17.1.	Software Upgrades and Installation	31	20.1.	Symbols	39
17.2.	Maintenance	31	20.2.	Product Graphics Glossary	40
17.3.	Cleaning and Disinfecting the Console	31	21.	Warranty Statement	41
17.4.	Calibration Verification	31			
18.	Specifications	31			

## 1. Introduction

Acessa Health Inc. is dedicated to providing service and support to its customers. If there are any questions concerning the use of the Acessa ProVu System, please contact Customer Service at:

**MANUFACTURED FOR:**

Acessa Health Incorporated  
317 Grace Lane, Suite 200  
Austin, TX 78746 USA  
Telephone: 877.412.3828  
Fax: 925.605.0327  
Email: [customerservice@accessahealth.com](mailto:customerservice@accessahealth.com)

## 2. Indications For Use

The Acessa ProVu System is indicated for use in percutaneous, laparoscopic coagulation and ablation of soft tissue, including treatment of symptomatic uterine fibroids under laparoscopic ultrasound guidance.

The Acessa ProVu System includes optional electromagnetic guidance for enhancing the ultrasonic image of the Acessa ProVu Handpiece and for predicting its future path on a computer monitor screen which also shows the ultrasound B-scan image.

## 3. Device Description and Components

The Acessa ProVu System provides radiofrequency (RF) ablation, ultrasound and guidance within a single console and includes additional accessories.

The Acessa ProVu System is designed to deliver monopolar radiofrequency (RF) energy to tissue through a disposable Handpiece. The System is capable of delivering up to 200W of power. The Console is specifically designed to be used only with Acessa Health manufactured devices. The Acessa ProVu System has temperature or power displayed depending on the mode being used to assist the physician in monitoring and controlling the ablation throughout the procedure.

The Acessa ProVu System must be used under laparoscopic ultrasound guidance. The basic function of ultrasound is to acquire ultrasound echo data and to display the image in ultrasound B-Mode. Ultrasound wave pulses released from transducer are reflected at the internal body system. Reflected waves are transmitted from the transducer, and ultrasound images are produced with the reflected image on the monitor. The system is designed for imaging with the Acessa ProVu System Transducer (5-12 MHz).

The Acessa Guidance System feature is an advanced electromagnetic spatial tracking system designed to calculate the position and orientation of sensors within a defined volume. The sensors are embedded in the tip of the Acessa ProVu Handpiece and the Acessa ProVu Transducer with Sensor, so that the system can determine the position and orientation to each other within the patient's abdominal cavity and display an animated image on a monitor.

**The Acessa ProVu System consists of:**

**The Console contains the following hardware and electronic components:**

- RF Ablation system
- Ultrasound system
- Guidance system

**The following accessories connect to the Console:**

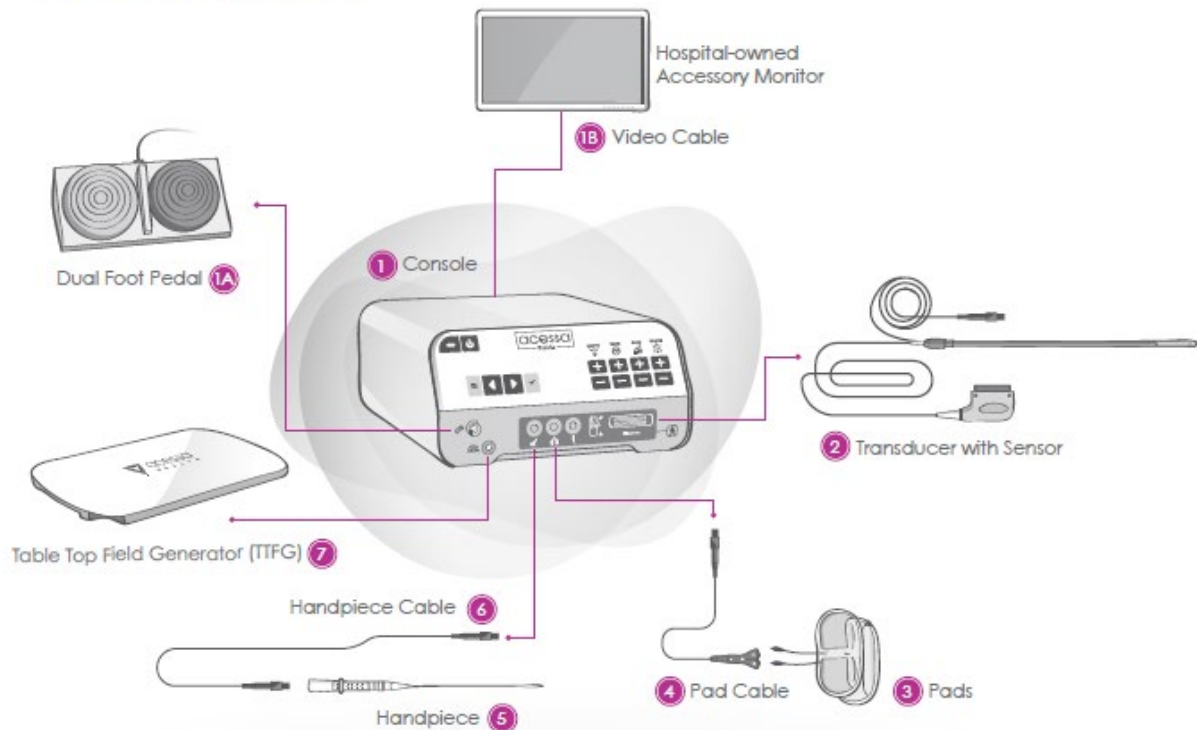

- Dual Foot Pedal (one for RF, one for coagulation)
- Video Cable
- Power Cord
- Acessa Pad (For IFU see PL-01-0015) and Acessa Pad Cable (For IFU see PL-01-0012)
- Acessa ProVu Handpiece (For IFU see PL-01-0038) and Acessa ProVu Handpiece Cable (For IFU see PL-01-0041)
- Acessa ProVu Transducer with Sensor (For IFU see PL-01-0044)
- Acessa Table Top Field Generator and Table Pads (Not Shown)
- Monitor (Hospital-owned, not provided by Acessa Health Inc. Monitor must have at least a 1920 x 1080 resolution and 27" or larger diagonal screen diameter preferred.)

# Acessa ProVu System



## The Acessa ProVu System consists of the following components:

- 1 Acessa ProVu System Console (Model Number 7100):**

  -  **Dual Foot Pedal (Part Number MS-06-0171):** Pneumatic foot pedals with tubing used to turn RF energy on and off. The foot pedal with tubing is provided with the Console.
  -  **Video Cable (Part Number MS-25-0107):** (Not Shown) An HDMI to DVI cable that connects the Console to the hospital-owned accessory video monitor.
  -  **Power Cord (Part Number MS-20-0050):** (Not shown) A medical grade power cord that provides AC power to the Console. The Power Cord is provided with the Console.
- 2 Acessa ProVu Transducer with Sensor (Model Number 7700):** A rigid probe, ultrasound transducer with sensor that connects to the Acessa ProVu Console.
- 3 Acessa Pads (Model Number 3000):** A disposable set of 2 units, providing the return path for the RF energy applied by the Handpiece. Use only the Pads provided by Acessa Health Inc.
- 4 Acessa Pad Cable (Model Number 4300):** Connects the Pads to the Console by a 2.9m extension cable.
- 5 Acessa ProVu Handpiece (Model Number 7300):** The disposable, guidance Handpiece delivers the RF energy used in the Acessa procedure.
- 6 Acessa ProVu Handpiece Cable (Model Number 7400):** Connects the Acessa ProVu Handpiece to the Console. This 2.4 m cable is provided separate from Handpiece.
- 7 Acessa Table Top Generator (Model Number 5200):** The Table Top Field Generator (TTFG) generates a magnetic field that is picked up by the magnetic guidance sensors in the Handpiece and the Ultrasound Transducer with Sensor. A 2.4m cable is provided with the TTFG that connects to the Console.

#### 4. Contraindications

- Patients who are not candidates for laparoscopic surgery (e.g. patients with known or suspected intra-abdominal adhesions that would interfere with safe use of the Handpiece).
- Uterus adherent to pelvic tissue or viscera.
- Non-uterine pelvic mass.
- Acessa ProVu System's guidance system is not intended for diagnostic use.
- The Acessa ProVu System's guidance system may not be used to guide the tip of the Handpiece once the tip has penetrated the uterine serosa. Ultrasound visualization must be used during fibroid penetration and treatment.

#### 5. Warnings

##### 5.1. General Warnings

- The safety of the electrosurgery will be greatly enhanced by a thorough knowledge of the medical literature on the subject. Study of specific information on the hazards and complications of the procedure in question is especially recommended.
- Read all instructions for use of the Acessa ProVu System prior to its use. Safe and effective electrosurgery is dependent not only on equipment design but also on factors under control of the operator. It is important that the instructions supplied with this equipment be read, understood, and followed in order to enhance safety and effectiveness.
- The safety and effectiveness of the Acessa ProVu System's electromagnetic tracking system to guide the tip of the Handpiece has not been evaluated in clinical trials. Therefore, the electromagnetic tracking system should only be used until the device has penetrated the uterine serosa.
- The Acessa ProVu System should only be used by physicians and qualified medical personnel trained in the safe use of electrosurgery and in the proper use of the Acessa ProVu System. After utilizing the Acessa ProVu System to determine the desired entry location into the uterus, the physician must verify the final placement of the Handpiece shaft and needles within the target tissue using ultrasound.
- DO NOT USE with hybrid trocar systems, i.e. a combination of metal and plastic, when using monopolar active components. This may result in alternate site burns due to capacitive coupling. Use only all-metal or all-plastic trocar systems.
- When not using instruments, place them in a clean, dry, highly visible area not in contact with the patient. Inadvertent contact with the patient may result in burns.
- Due to concerns about the carcinogenic and infectious potential of electrosurgical byproducts (such as tissue smoke plume and aerosols), protective eyewear, filtration masks, and effective smoke evacuation equipment should be used in laparoscopic procedures.
- DO NOT activate the Handpiece when not in contact with target tissue, as this may cause injuries due to capacitive coupling with other surgical equipment.
- The surface of the active electrode may remain hot enough to cause burns after the RF current is deactivated.
- Re-use of the Handpiece or Transducer Sleeve may result in patient post-operative infection. These accessories are for single use only.
- When positioning the Handpiece, confirm proper placement prior to initiating treatment (RF energy activation). Neuromuscular stimulation could cause injury due to unwanted muscle contractions.
- Electric shock hazard. Acessa ProVu System Console must only be used with an IEC/EN/UL/CSA 60950 or 60601-1 certified monitor.
- Electric shock hazard. Do not remove the cover of the Console. Refer all service to Acessa Health Inc. There are no user-serviceable parts inside the Console.
- Electric shock hazard. Do not saturate the Console with liquids. Do not allow liquids to run inside the unit. Do not immerse the unit in water. Shut off the Console and disconnect power before cleaning. Do not sterilize the unit.
- Electric shock hazard. Console must only be connected to a supply mains with protective earth.
- When applying the Pads as described in this document or the Pad IFU (PL-01-0015), if it is found that the Pads will overlap, the Acessa ProVu System **cannot be used** for that patient. **SEVERE SKIN BURNS MAY RESULT.**
- FOR SINGLE USE ONLY! Re-use of the Pads may result in patient burn and/or infection.
- FOR SINGLE USE ONLY! Re-use of the Handpiece may result in patient post-operative infection.
- Treatment of children is limited due to the physical size and placement of Pads with respect to RF ablation site.
- Treatment with the Acessa ProVu System is not recommended for nursing mothers or pregnant women.
- Electrosurgery is not recommended for patients with metal implants near the ablation site or along the RF return path to Pads.
- Safety of using heat or cryo during or following the Acessa procedure has not been studied.
- If the patient has a pacemaker, consult the patient's cardiologist prior to this procedure. Using the Acessa ProVu System in the presence of an internal or external pacemaker may require special considerations.

- In the case of a pacemaker, a possible hazard exists because interference with the action of the pacemaker may occur, and the pacemaker may become damaged. Questions should be directed to the attending Cardiologist, or to the pacemaker manufacturer.
- Do not use the Acessa ProVu System during cardiac defibrillation.
- The Transducer should not be used to manipulate the bowel during the procedure due to the risk of bowel injury.
- ONLY Acessa Health Inc. accessories may be attached to and used with the Acessa ProVu System. The Acessa ProVu System is not compatible with any other RF devices or electro-magnetic guidance devices.
- Use of accessories, transducers and cables other than those specified or provided by the manufacturer of this equipment could result in increased electromagnetic emissions or decreased electromagnetic immunity of this equipment and result in improper operation.
- For surgical procedures where the RF current could flow through parts of the body having a relatively small cross sectional area, the use of bipolar techniques may be desirable in order to avoid unwanted tissue damage.
- The device should not be used on patients with bleeding disorder or an anticoagulant therapy.
- No modification of this equipment is allowed.
- **The connector of the TTFG must be positioned on the side of the patient opposite the physician.**
- The Acessa ProVu System is sensitive to strong radiated and conducted electromagnetic interference. In the event of such interference, the Console will cease displaying guidance information and will display an alert message. The user should discontinue use of the Acessa ProVu System until the source of the interference can be determined and removed.

#### 5.2. Environmental and EMI Warnings

- In the case of a pacemaker, a possible hazard exists because interference with the action of the pacemaker may occur, and the pacemaker may become damaged. Questions should be directed to the attending Cardiologist, or to the pacemaker manufacturer.
- Any additional monitoring electrodes should be placed as far as possible from the Handpiece and should incorporate high-frequency current limiting devices. Needle monitoring electrodes are not recommended.
- Do not use flammable anesthetics, gases, or liquids while the system is in use. The risk of igniting flammable gases or other materials is inherent in electrosurgery and cannot be eliminated by device design. Precautions must be taken to avoid contact of flammable materials and substances with electrosurgical electrodes, whether they are in the form of an anesthetic or skin preparation agent, or produced by natural processes within body cavities, or originate in surgical drapes, tracheal tubes or other materials.
- ASPIRATE fluid from the area before activating the instrument. Conductive fluids (e.g. blood or saline) in direct contact with or in close proximity to an active electrode may carry electrical current or heat away from target tissues, which may cause unintended burns to the patient.
- There is a risk of pooling of flammable solutions under the patient or in body depressions such as the umbilicus, and in body cavities such as the vagina. Any fluid pooled in these areas should be removed before RF surgical equipment is used.
- The presence of endogenous gases may create an ignition hazard. Ensure that the operating room is well ventilated.
- Some materials, for example cotton, wool and gauze, when saturated with oxygen may be ignited by sparks produced in normal use of the RF surgical equipment.
- This equipment has been tested and found to comply with the EMC limits for the Medical Device (CISPR 11 Class A and IEC 60601-1-2). These limits are designed to provide reasonable protection against harmful interference in a typical medical installation, however, in some cases of input power fluctuations or transients (electrical fast transient, conducted immunity, and voltage dips/interrupts), compliance is achieved by safe shutdown into standby mode. If the unit responds to an EMI event by shutting down, then it will be necessary to manually reboot the system by use of the Standby pushbutton on the front of the Console. The equipment generates, uses, and can radiate radio frequency energy, and if not installed and used in accordance with these instructions, may cause harmful interference to other devices in the vicinity. Per the IEC 60601-2-2 standard, compliance to radiated emissions is only tested in the Ready Mode; however, during ablation or coagulation known interference will be generated which degrades nearby AM radio receivers and other equipment sensitive to harmonics of the 460 kHz RF Generator operating frequency. There is no guarantee that interference will not occur in a particular installation. If this equipment does cause harmful interference with other devices, which can be determined by turning the equipment off and on, the user is encouraged to try to correct the interference by one or more of the following measures:
  - Reorient or relocate the receiving device.
  - Increase the separation between the equipment.
  - Connect the equipment into an outlet on a circuit different from that to which the other device(s) is/are connected.
  - Consult the manufacturer or field service technician for help.
- The use of Pads, Handpiece, Cables, and accessories other than specified, with the exception of those devices sold by Acessa Health Inc. for the system as replacement parts for components may result in increased emissions or decreased immunity of the Acessa ProVu System.

- Electric shock hazard. Do not saturate Console with liquids. Do not allow liquids to run inside the unit. Do not immerse the Console in water. Shut off the Console and disconnect power before cleaning. Do not sterilize the Console or Pads.

### 5.3. Warnings During Electrosurgical Device Use

- Pad temperatures normally remain within a few °C of their starting temperature but occasionally can rise further for long ablations or higher than normal tissue impedance. The user is advised to have an external cooling system setup nearby in standby for this contingency. Do not use dry ice.
- Cables connected to the device should not contact the patient or other electrical leads.
- Skin-to-skin contact, such as between the torso and the arms or between the legs of the patient should be avoided by insulating these contacts with sheets or dry gauze.
- Keep the Handpiece active electrode arrays clean. Build-up of eschar may reduce the instrument's effectiveness. Do not activate the instrument while cleaning. Injury to operating room personnel may result.
- Do not touch the Handpiece tip and Pads at the same time especially when operating the Console, as capacitive coupling may lead to burns.
- When using the device in situations where vision may be limited, burns may result if the device is activated outside the field of view.
- Failure of high frequency surgical equipment could result in an unintended increase of output power.
- Ablation RF Output is active without continuous activation of the Foot Pedal. Care needs to be taken to avoid over-exposure of RF energy which may result in tissue damage or adjacent tissue damage.
- When not in use, electrosurgical leads (active or return) should be positioned so that they cannot come into contact with the patient, other leads or any metal objects.

### 5.4. Warnings Specific to the Acessa ProVu System

- Apparent low power output or failure of the electrosurgical equipment to function correctly at normal settings may indicate faulty application of the Pads or failure of an electrical lead.
- For monopolar surgery, effective contact between the patient and the Pads must be verified whenever the patient is repositioned.
- The proper use and placement of the Pads are key elements in the safe and effective use of monopolar electrosurgery, particularly in the prevention of burns. Follow directions and recommended practices for the preparation, placement, surveillance, removal and use of the Pads. Use with the system in accordance with your facility's standard operating procedure, Acessa Health's instructions, and AAMI standards.

### 5.5. Warnings Concerning Acessa ProVu System Guidance Accuracy

- Do not use the Acessa ProVu System guidance system without the Table Top Field Generator (TTFG) and Pad Set (MS-26-0022). The generator should be below the patient's pelvis.
- Do not drop the Field Generator or subject it to impact. Physical damage to the Field Generator may alter its calibration and contribute to inaccurate guidance.
- Do not place the Acessa ProVu System closer than 1m from the Field Generator. To do so may affect the tracking accuracy.
- Only plastic or compatible metals may be in the magnetic field. The Acessa ProVu System guidance system works by generating magnetic fields from its TTFG. Take care when using the system to not place ferromagnetic objects upon the Field Generator or within the tracking volume, or accuracy may be affected. Those metals specifically known to cause tracking disruptions are: mild steels such as DIN 1.4034 or DIN 1.4021, Aluminum alloys and 400 series stainless steel. The following metal alloys do not affect the Acessa ProVu System: titanium (TiA16V4); and 300 series stainless steel.
- Do not coil the TTFG cable or place it inside the tracking volume or wrap it around the TTFG, as it may create magnetic interference.
- Do not place the Handpiece cable within 30 mm of the TTFG cable.
- Do not wrap the Handpiece cable around the Transducer cable or Console cables.

### 5.6. Warnings Specific to Uterine Fibroid Ablation

- Insufficient data exist on which to evaluate the safety and effectiveness of Acessa procedure in women who plan future pregnancy. Therefore, the Acessa procedure is not recommended for women who are planning future pregnancy.
- To reduce the risk of injury to organs outside of the uterus, electrode tips must be deployed no closer than 1 cm from the fibroid margin in all planes.
- Always verify that the electrode arrays are fully retracted before positioning, advancing, or withdrawing the Handpiece.
- The Handpiece tip should be allowed to cool for at least 60 seconds after the ablation has stopped, prior to removing it from the target tissue.
- To reduce the risk of hematoma, identify the inferior epigastric arteries prior to percutaneous insertion of the Handpiece.



- The safety and effectiveness of the Acessa procedure has not been evaluated in women with uterine size >14 weeks.
- Uterine tissue may contain unsuspected cancer, particularly in patients who are peri- or post-menopausal. Insufficient data exist on which to evaluate the safety and effectiveness of Acessa procedure for treatment of cancerous uterine tissue. Thoroughly discuss the benefits and risks of all treatments with patients.
- Do not substitute transabdominal or transvaginal ultrasound for laparoscopic ultrasound when performing the Acessa procedure.

## 6. Precautions

### 6.1. General Precautions

- Do not use the Acessa ProVu System if any of the hardware components, cables, or connectors are damaged. Such damage may affect system functionality.
- If the system becomes unresponsive during a procedure, reboot the system. If the problem persists, call Acessa Health Inc. customer service, refer to §1 for applicable contact information.
- Reusable accessory cables should be periodically inspected for damage to insulation and tested for function and safety in accordance with the cable's instructions for use.
- The Hospital-owned accessory video monitor (an IEC/EN/UL/CSA 60950 or 60601-1 certified monitor) must have at least a 1920 x 1080 resolution and a DVI input. A 27" or larger diagonal screen is preferred.
- Position the Console to allow adequate ventilation during operation.
- Arrange cables to minimize trip hazard and avoid damage.
- Position the Console to allow easy access to the On/Standby power switch on front of Console.
- Dispose of used Handpieces, Pads, and Cables in accordance with local, state, and national bio-waste laws and regulations.
- Always turn the Console power OFF before connecting or disconnecting the power cord and TTFG cable. Not doing so may result in sparks being generated.
- The Console should not be used adjacent to or stacked with other equipment. The system should be observed to verify normal operation in the configuration in which it will be used.
- Portable and mobile radio frequency (RF) communications equipment can affect the Acessa ProVu System functionality.
- Do not expose the Handpiece or Transducer with Sensitive to a high magnetic field such as a Magnetic Resonance Imaging (MRI) scanner, as they may become magnetized and affect system functionality.
- Mains power quality should be that of a typical commercial or hospital environment. If the user of the Acessa ProVu System requires continued operation during power mains interruptions, it is recommended that the Console be powered from an uninterruptible power supply.
- Do not use abrasives, caustics, or mineral spirits. Use of these agents to clean the Console or any of its accessories may cause damage and voids the warranty. All electrical connection ports must be air-dried before use.
- The output power selected should be as low as possible for the intended purpose.

### 6.2. Environmental and EMI Precautions

- Non-flammable agents should be used for cleaning and disinfection wherever possible. (See Cleaning and Disinfecting instructions and precautions for the validated cleaning agent. (§17.3)
- Interference produced by operation of high-frequency surgical equipment may adversely affect the operation of other electronic medical equipment such as monitors and imaging systems. This can be minimized or resolved by rearranging monitoring device cables so they do not overlap the Acessa ProVu System's cables.

### 6.3. Precautions During Electrosurgical Device Use

- Due to the non-homogenous conduction that occurs near organ surfaces or vasculature, shapes of ablations performed in these areas may be altered. Careful planning is needed for targets in these locations
- Any application or procedure that alters tissue perfusion and affects temperature elevation should be monitored carefully.

### 6.4. Precautions Specific to the Acessa ProVu System

- A USB flash memory device is the only device that should be inserted into the back panel USB port (USB port, Item T as shown in §8.4). This port is for Acessa Health personnel only.

### 6.5. Precautions Concerning Acessa ProVu System Guidance Accuracy

- The System's guidance capability has  $\pm 10$  mm accuracy.

### 6.6. Precautions Specific to Uterine Fibroid Ablation

- Avoid excessive pressure (e.g. lateral pressure) on the Handpiece which could bend or damage the shaft and/or electrode array.

- To avoid damage to the electrode arrays, maintain stability of the uterus position and do not rotate the Handpiece when electrodes are deployed in tissue.

**7. Sterilization and Safety Checks**

- Inspect the Handpiece and Pads packaging for damage.
- Inspect the Handpiece and Pads for any obvious damage.
- Inspect the medical grade power cord for insulation damage or frayed wire connections.
- Sterilize the Transducer in accordance with the recommended process in the Instructions for Use accompanying the Acessa ProVu Transducer with sensor. Ensure that the cable interconnections are clean and dry prior to use.
- Clean and sterilize the Handpiece Cable in accordance with the recommended process in the Instructions for Use accompanying the Handpiece cable. Ensure that the cable interconnections are clean and dry prior to use.
- Clean and disinfect the Pad Cable in accordance with the recommended process in the Instructions for Use accompanying the cable. Ensure that the Pad cable interconnections are clean and dry prior to use.
- The Console, Foot Pedal, and Field Generators (TTFG) should be cleaned and disinfected per §17.3.

**8. Switches, Buttons, Connections, and Display**

**8.1. Front Panel**

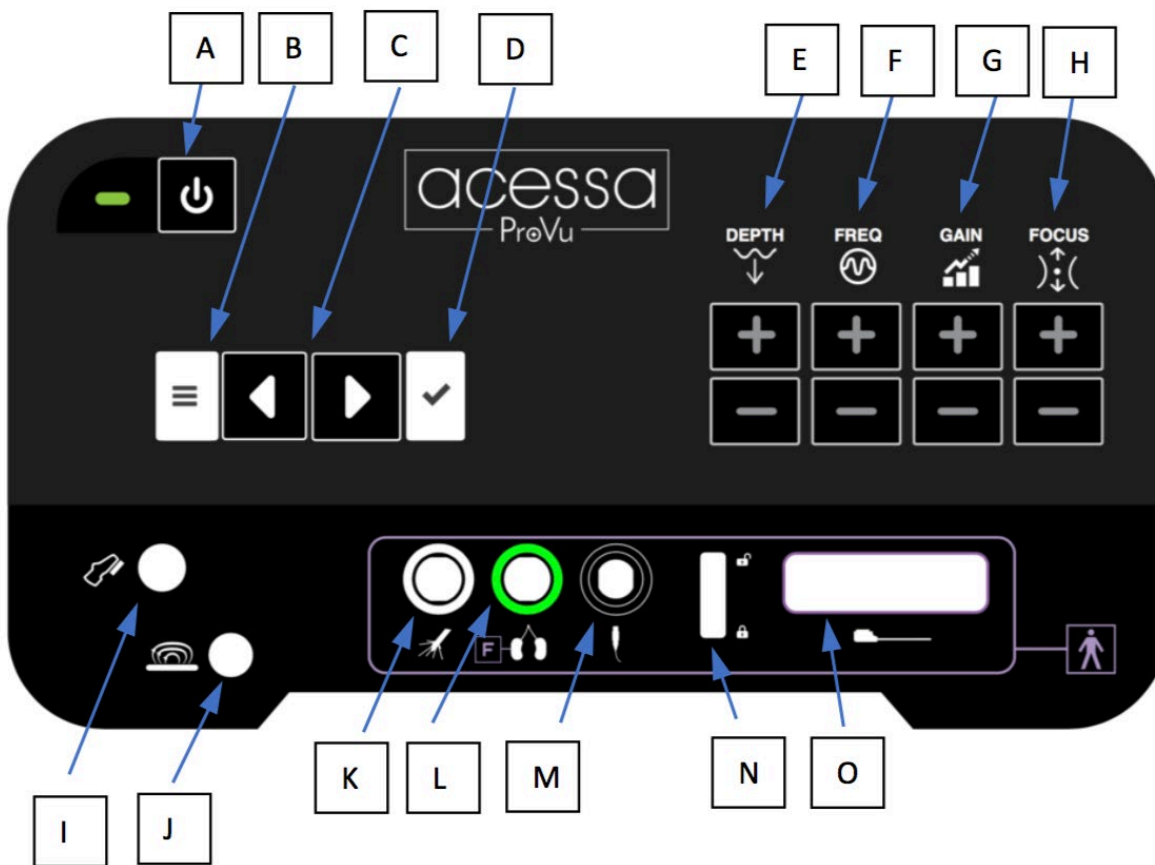

**8.2. Buttons, Connections and Display**

- On/Standby Button, LED Indicator**  
 Push to turn Console ON (LED will turn green). Push again to get to the shutdown screen. The Console is in “Ready” mode when on. If emergency RF shutoff is required during ablation, the user can turn off RF power by momentarily pressing the front panel On/Standby button.
- Menu Button**  
 Brings up the menu to access the user-adjustable settings.
- Menu Scroll Buttons**  
 Allows the user to scroll through the menu items. The user-adjustable items are: full-screen ultrasound mode, ablation volume guide on/off, coagulation power level, OR setup menu, and sound volume. The menu will be visible when the user presses the menu button on the front console, and otherwise hidden.

- D. Check Button  
Used to accept the current menu item.
- E. Ultrasound Depth Adjustment  
Pressing the + (up) or – (down) buttons will adjust the Depth or magnification of the ultrasound image. The supported ultrasound depths are: 3cm, 4cm, 5cm, 6cm, 7cm, 8cm, and 9cm.
- F. Ultrasound Frequency Adjustment  
Pressing the + (up) or – (down) buttons will adjust the Frequency of the ultrasound. The supported frequencies are: 5MHz, 6MHz, 9MHz, and 12MHz.
- G. Ultrasound Gain Adjustment  
Pressing the + (up) or – (down) buttons will adjust the Gain of the ultrasound.
- H. Ultrasound Focus Adjustment  
Pressing the + (up) or – (down) buttons will move the Focus of the ultrasound. The supported focal depths are: 0.2cm, 0.4cm, 0.7cm, 1cm, 1.4cm, 1.8cm, 2.3cm, 3cm, 4cm, 5cm, 6cm, and 8cm.
- I. Dual Foot Pedal Connector  
Accepts the connector from the foot pedal tubing.
- J. Field Generator Connector  
Accepts the connector from either the Table Top Field Generator or Planar Field Generator.
- K. Handpiece Connector  
Accepts either end of the Handpiece Cable.
- L. Return Pad Connector  
Accepts the Pad Cable.
- M. Transducer Sensor Connector  
Accepts the cable from either the Transducer Sleeve, or the sensor cable from the Transducer with Sensor.
- N. Transducer Connector Lock  
Locks the Transducer connector in place.
- O. Transducer Connector  
Accepts the connector from the Transducer.

### 8.3. Rear Panel

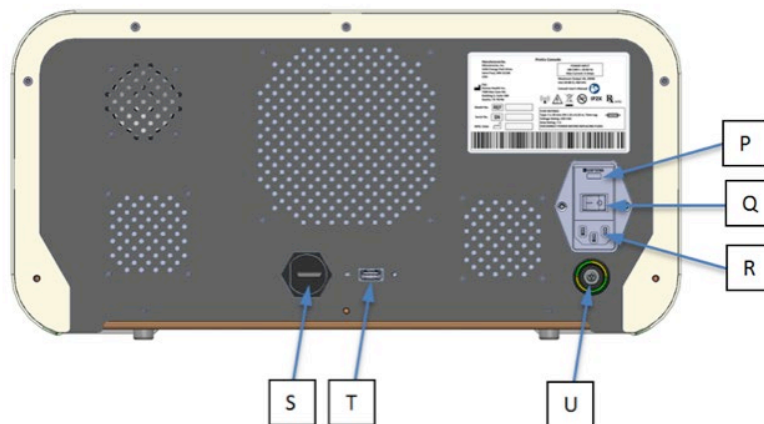

### 8.4. Switches and Connections

- P. Fuse Door  
The power Inlet takes two 5.0 Amp 250 volt fuses.
- Q. Main Power Switch  
Main power switch. Positions are ON (I) and OFF (O).
- R. Power Cord Inlet  
Port for connecting the Console to power via the medical-grade power cord.
- S. HDMI Video Connector  
Port for connecting an external 1920 x 1080p monitor.
- T. USB Port  
This port is for ACESSA Health personnel only.
- U. Equipotential Terminal  
Potential Equalization Terminal. This terminal is available for providing a direct connection between other electrical equipment for potential equalization (if needed).

## 9. Setting up the Acessa ProVu System

### 9.1. Connecting System Components

- Verify that components have been checked and sterilized as described in §7.

### 9.2. Before Patient Arrives

- Before Patient arrives set up appropriate Field Generator.
- Acessa Table Top Field Generator (TTFG) setup: remove the standard OR table pads from the OR table first.
- Place the TTFG Pads (MS-26-0022) on the OR Table.
- Place the TTFG inside of the TTFG pad.

**Caution: The TTFG *must be* oriented with the connector port opposite the side of the surgeon. Refer to the labels on the sides of the TTFG for proper orientation.**

- Position the TTFG and Table pads configuration, end with the TTFG closest to the end of the pads, aligned with the break in the bed.
- Place and align the remaining pads to cover the remainder of the exposed OR table.
- Next replace the standard OR table pads back on top of the TTFG pads by aligning the adjoining velcro strip of the OR pads accordingly with the TTFG and Table pads configuration.

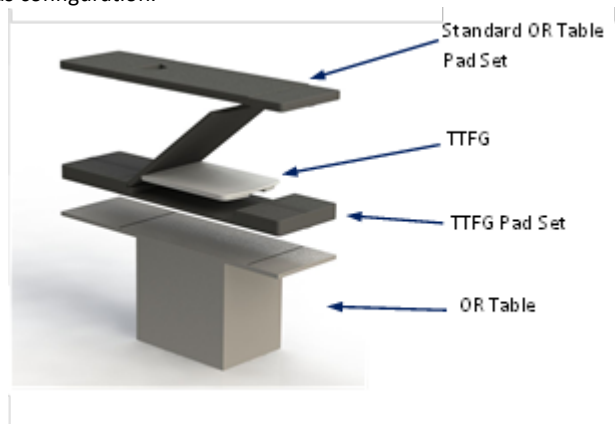

- Plug the TTFG Cable into the TTFG Cable port.
- Connect the supplied medical grade power cord into the Console at Port R on the rear panel, and then to the wall outlet.
- Connect the Video Cable to Port S on the rear panel and the other end to a 1920 x 1080p hospital-owned accessory monitor. A screen size of 27 inches *minimum* is recommended.

### 9.3. Patient Preparation

- Remove a set of Pads from its pouch. Leave the Mylar covers intact over the gel and connect the pigtail cables to the wye of the pads cable. Ensure that the pad marked "R" is connected to the wye marked "R" and similarly "L" to "L" for the other pad. Affix the Return Pads to the patient per the Pad IFU (PL-01-0015). Consult Pads Instruction for Use for prep of patient and proper Pads placement.
- Apply the Pads per the figure below. The Pads must be used with the Acessa ProVu System. The entire surface area of the Pads must be reliably attached to the patient's body.
- The leading edge of the Pads should be between 25cm and 50cm from the ablation site.
- If desired temperatures are not achieved when RF energy is delivered, check that the Pads have been placed according to the Instructions for Use. Proper Pads placement is essential to a successful Acessa procedure.

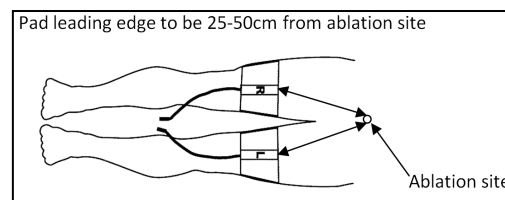

**WARNING: Skin burns may occur if the Pads are not placed as instructed.**

- Prepare the patient using the standard technique for electrosurgery. The patient's entire body, including extremities, must be insulated against contacts with metal parts which are earthed or which have an appreciable capacitance to earth (for example operating table supports, etc.). The operating table should be grounded, and sufficient layers of electrically insulated sheets should be placed underneath the patient. The use of antistatic sheeting is recommended for this purpose. A waterproof cover should be placed over the insulating sheets, with absorbent sheets placed between the patient and the waterproof cover to absorb any moisture.
- Connect the Pad Cable to the Console at Port L.

- Connect the Handpiece to the Handpiece Cable, pass the other end of the cable from the sterile field and connect it to Port K on the front of the Console. The Console and Handpiece use the same connector which makes the cable bidirectional.
- Connect the Dual Foot Pedal to the Console at Port I. (Note: The Dual Foot Pedal may be elevated off the floor via foot stool to limit accidental activation/deactivation.)
- Connect the Field Generator cable to the Console at Port J.
- Pass the Transducer with Sensor (Model 7700) ultrasound connector from the sterile field and connect to the Console at Port O. Use the toggle lock at Port N on the Console front panel to lock the Transducer connector in.
- Pass the Transducer with Sensor (Model 7700) navigation connector from the sterile field, and connect it to the Acessa ProVu Console's front panel via Port M.
- Skin-to-skin contact, such as between the torso and the arms and between the legs of the patient should be avoided by insulating these contacts with sheets or dry gauze.
- Any monitoring electrodes should be placed as far as possible from the Handpiece, and should incorporate high-frequency current limiting devices. Cables connected to the Console should not contact the patient or other electrical leads.
- Low power output or failure of the Console to achieve target temperature within approximately 2 minutes may indicate faulty application or connection of a Pad.
- The accessories can be connected before or after the system has been powered ON (except TTFG cable and power cord, which must be connected prior to system power ON).

#### 9.4. Energizing The System

- Place the power switch on the rear panel, Port Q, to the On (I) position. This energizes various internal power supplies and lights the orange LED on the upper left of the front panel at Port A. The system is now in Standby Mode and awaiting Power On Self-Test (POST).
- With the system in Standby mode, depress the "Standby" front panel pushbutton at Port A, and observe that the LED light up and turns green. The user should also note that the internal fan starts at the same time. The computer boot sequence progresses through POST and finishes at the Acessa ProVu splash screen.
- If POST failed, an Error screen will display. Turn the Console off and then turn it on again. If POST fails again, contact Customer Service at Acessa Health Inc.

## 10. Use of the Acessa System

### 10.1. Getting Ready

- All navigation and control of the system is done through the buttons on the front panel.
- Starting and stopping the delivery of Radiofrequency (RF) energy and Coagulation is done with the Dual Foot Pedal.
- The menu is accessed by pressing on the Menu button.
- The Scroll buttons moves left or right to the next menu item.
- The Accept/Acknowledge button accepts a selection. If an Alert appears that requires acknowledgement, this button must be pressed.



When the system starts up, it will go through a Power On Self Test (POST). This tests the system to ensure that everything is functioning correctly. When this test passes, three beeps will be heard that means the system is ready to use.

Next, the User Interface screen will appear and start with the selection of the OR layout. See figure below:

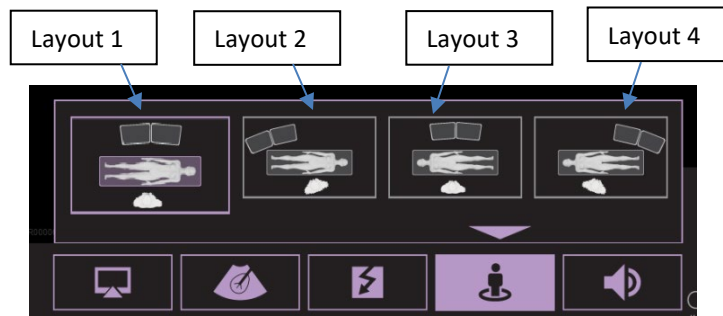

The four options are:

- Layout 1: Monitors are at the patient's right, surgeon is on the patient's left. The left side shows Guidance, and the right side shows the ultrasound.
- Layout 2: Monitors are at the patient's feet, surgeon is on the patient's left. The right side shows Guidance, and the left side shows the ultrasound.
- Layout 3: Monitors are at the patient's left, surgeon is on the patient's right. The right side shows Guidance, and the left side shows the ultrasound.
- Layout 4: Monitors are at the patient's feet, surgeon is on the patient's right. The left side shows Guidance, and the right side shows the ultrasound.

The screen layout is most efficient if the ultrasound side is closest to the laparoscope monitor.

### 10.2. Accessory Connections

The Accessory Connection Dialogue Box is displayed in the lower right corner of the screen. See below:

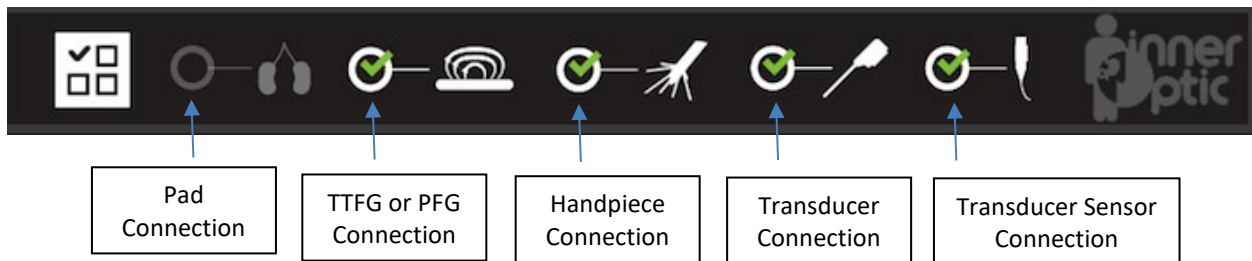

- As the accessories are connected, the screen will display proper connection by changing the gray icon to a white icon with a green check inside the white icon.
- When all the accessories are connected, the Accessory Connection dialogue box will disappear and a green check will appear. This means that all accessories are connected and working properly. The system is now ready to use.



10.3. User Interface



Upper Left: Deployment, Ablation, Coag	Center Top: Expected Ablation Size	Upper Right: Ultrasound Settings
	Center Middle: Proximity Meter	
Lower Left: Menu Selections	Lower Center: Pad Temperatures	Lower Right: Accessory Connections

10.4. **Menu Settings**

- Access menu settings when the Menu button is pressed or there are any alert messages.

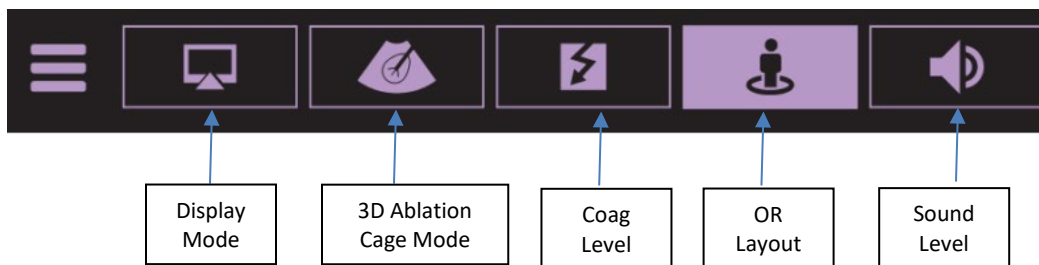

- Display Mode – Switch between Ultrasound plus Guidance mode or full Ultrasound only mode on screen.
- 3D Ablation Cage Mode – This mode turns the optional 3D Ablation Cage ON or OFF. This tool is used to approximate the expected fibroid size to be ablated.
- Coag Level – This allows the user to select the Coag power level. The range is 1 – 20.
- OR Layout – This allows the user to select one of the four (4) OR layout options.
- Sound Level - This allows the user to select the sound output power level. The range is 1 – 15. The sound level cannot be changed for alert notification sounds.
- Pressing the Menu button once on the front panel will activate the menu items and pressing a second time will minimize the menu.

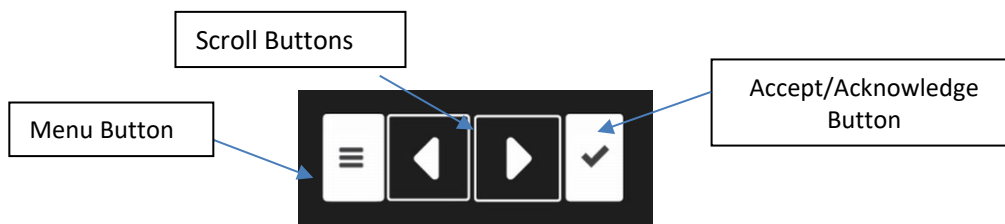

10.5. **Ultrasound Settings**

- Access to the Ultrasound settings is via the front panel of the Console.
- Depth – The Depth (magnification) options are: 3cm, 4cm, 5cm, 6cm, 7cm, 8cm, and 9cm.
- Frequency – The Frequency (penetration/resolution) options are: 5MHz, 6MHz, 9MHz, and 12MHz.
- Gain – The Gain (brightness) options are: 0 – 100%, in 1% increments.
- Focus – The Focus (near zone/far zone) options are: 0.2cm, 0.4cm, 0.7cm, 1cm, 1.4cm, 1.8cm, 2.3cm, 3cm, 4cm, and 5cm.



10.6. **Expected Ablation Size**

- A pictorial representation of the expected ablation based on the user Handpiece deployment; Correlates with the tables on §12.3 and §12.4. The ablation size in centimeters. (length x width).

10.7. **Deployment, Ablation and Coag**

- Deployment: Displays the amount of deployment of the electrode arrays in centimeters.
- Target ablation time: Target time is set based on the Handpiece deployment settings chosen.
- **Ready-Ablate State:** In Ready-Ablate State (Figure below), the upper left-hand frame has a yellow outline. The Handpiece temperature (in Celsius) and power (in Watts) are also displayed. The user will use the left foot pedal (yellow) to activate ablation when ready. The yellow highlight indicates the Ready-Ablate state visually to the user.





- Ablate State.** In Ablate State (Figure below), the upper left-hand frame has a yellow background, and the array is colored maroon to indicate RF delivery. The user depresses the left foot pedal (yellow) a second time to activate RF. If the user does not depress the foot pedal a second time within 5 seconds, the system goes back to a neutral state. The RF system adjusts power to provide a smooth upward ramp until target temperature has been reached. Ramp icon is displayed beside the ablation temperature. Under normal conditions the ablation continues until the time at target corresponds to the empirically determined time and deployment for the desired ablation size. Refer to tables on §12.3 and 12.4. At this point the user must manually turn off the RF energy by again depressing the foot pedal; an audible finish tone sounds.



- Ready-Coag State.** In Ready-Coag State (Figure below), a different left-hand frame is outlined in blue. The settings allow for 1-20 (power level), and default is always set to 12 or the last setting chosen. Immediately following a completed ablation, the user is ready to cauterize the Handpiece track. First, the user retracts the device electrode arrays, then depresses the right foot pedal (blue) to activate the Ready Coag state which enables the sounding of the system.



- Coag State.** In Coag State (Figure below), the upper frame has a blue background to indicate RF delivery and the timer panel will show the elapsed time for coagulation. The user depresses and holds the right foot pedal (blue) to begin coag, which enables sounding of the system. If the user does not depress the foot pedal a second time within five (5) seconds the system goes back to a neutral state. The system provides a coag power output proportional to the level setting. The user slowly withdraws the Handpiece while visually monitoring the coag laparoscopically, adjusting level setting as necessary to achieve optimal results. Turn off RF power when track coagulation is completed by releasing the foot pedal.



10.8. **Pad Temperatures**

- Each pad has three thermocouples. Only the temperature of the warmest thermocouple is displayed on the screen. The left temp is for the left pad, and the right temp is for the right pad.
- When the temperature of the warmest thermocouple reaches 40°C, that pad temperature will change to yellow.
- When the temperature of any thermocouple on either pad reaches 44°C, RF energy will no longer be delivered. The pads must be cooled before ablation can be restarted. Coag can still be done if a pad temp reaches 44°C.

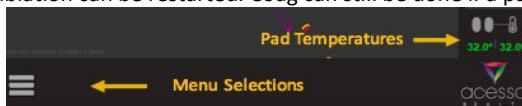

10.9. **The Acessa ProVu Guidance System Feature**

- The Guidance System feature allow the physician to see the Ultrasound Transducer and the Handpiece shaft images in real time as they are being positioned within the abdominal cavity. It places the image from the ultrasound machine onto a virtual ultrasound transducer plane and displays a “Target Zone” with purple lines where the Handpiece shaft will intersect the plane.
- The Guidance System feature is intended to be used as an adjunct to the standard ultrasound image to assist the positioning of the Handpiece during the Acessa Procedure. The Guidance System feature aids in showing where the tip of the Handpiece would intersect the ultrasound plane. Once the tip of the Handpiece penetrates the uterine serosa, ultrasound visualization must be used to complete the process of positioning the Handpiece in the fibroid for the Acessa procedure treatment.
- After using standard ultrasound imaging as described in the Acessa procedure to locate and map a fibroid for treatment (see Figure to the right for menu selection of ultrasound only). The Guidance System can be used to help determine the optimum location to enter the uterus with the tip of the Handpiece.

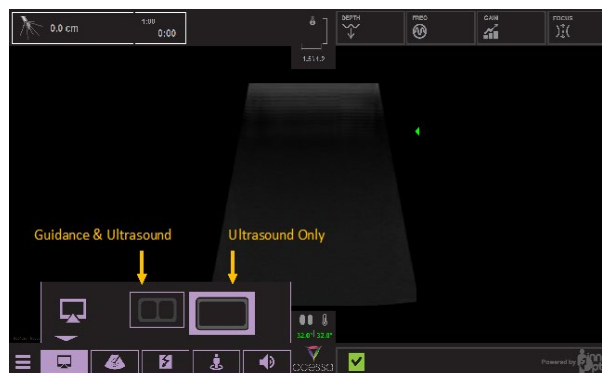

- Position lines:** On the 3D view, if the trajectory is “in front of” the ultrasound plane, yellow lines will appear. If the trajectory is “behind” the ultrasound plane, blue lines will appear. The spacing of these lines does not represent any specific distance or measurement.
- Proximity Meter:** The meter in the center of the screen shows the location of the Handpiece tip relative to the ultrasound plane and is most useful when approaching the target with the Handpiece tip in the plane of the ultrasound. If the tip is in front of the plane, yellow bar lines will be displayed on the meter. If the tip is behind the plane, blue bar lines will be displayed. When the tip is “on plane” with the ultrasound image, a green bar line in the center of the meter will be displayed. The spacing of these bar lines does not represent any specific distance and measurements should not be taken using them. If the Handpiece is inserted out of plane, do not use the meter, reference the 2D display.

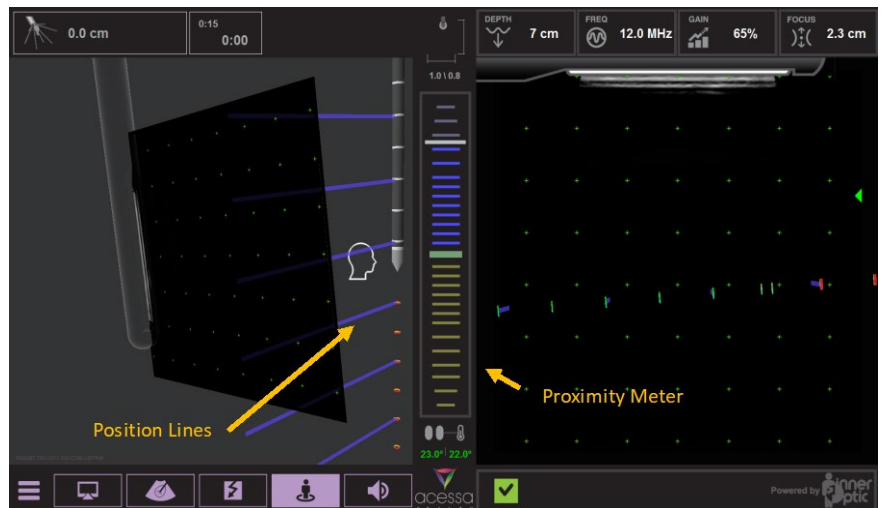

- Handpiece-ultrasound Target Zone** The software provides a prediction of the Handpiece's path and its projected intersection point with the ultrasound scan (target zone), so the user can orient the Handpiece to the target fibroid before inserting it. It is drawn in both the 2D and 3D views as a purple obround-shaped indicator (target zone), superimposed over the ultrasound scan plane. The size of the obround changes with the angle of the Handpiece to the ultrasound scan plane; when the Handpiece is perpendicular to the scan plane, the obround is a circle, and as the angle decreases toward parallel, the obround is drawn as two lines capped with semi-circles at the ends. The Handpiece trajectory hash marks are displayed in both the 2D and 3D views. When the hash marks are displayed as red and yellow the Handpiece trajectory is distal to the ultrasound scan plane and when green hash marks are displayed the Handpiece is within the ultrasound plane. The double green hash mark is representative of the Handpiece tip.

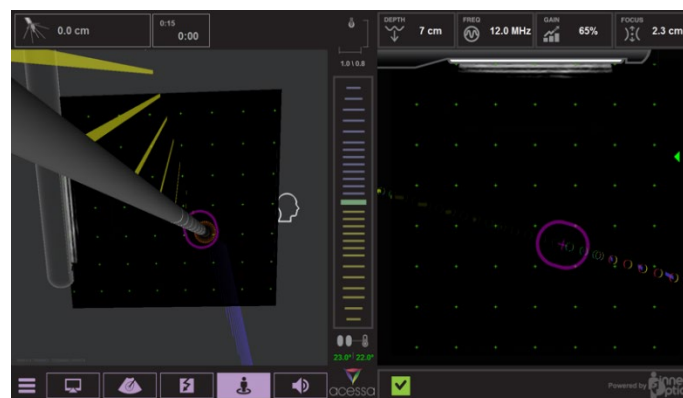
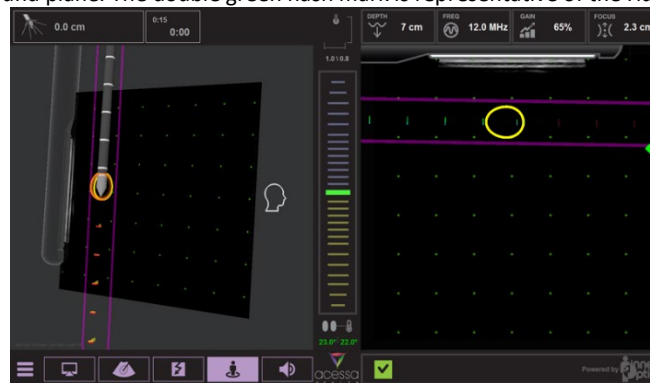

- **Expected 3D Ablation Cage.** The software can optionally display a visual indicator of the expected ablation volume at the end of the handpiece, shown in orange. This volume guide provides the user with a 3D visual reference for physical dimensions to further assist in electrode array placement. The dimensions and distance from the handpiece's tip are drawn according to the tables on §12.3 and 12.4.

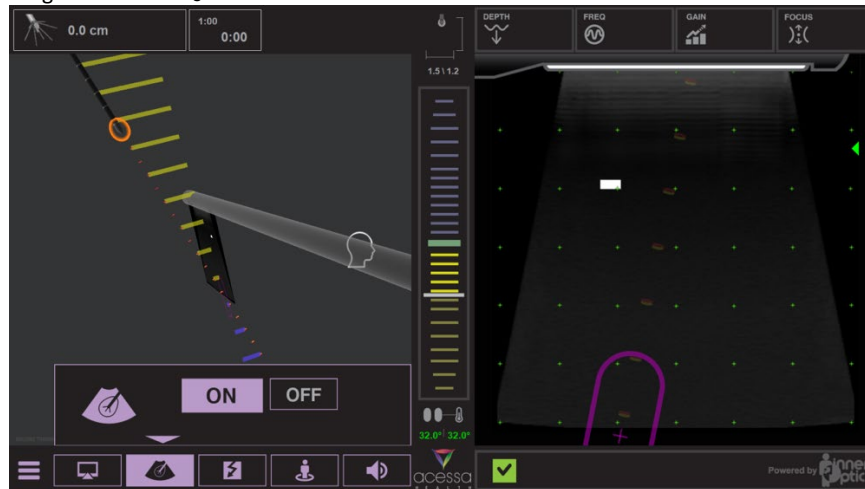

#### 10.10. Procedure Planning

- The physician should determine the scope and sequence of ablations prior to starting any RF energy. Using the ultrasound, examine the uterus and map the fibroids that are present. After all fibroids are documented, determine the sequence of ablations and path of Handpiece insertion.

#### 10.11. Performing an Ablation

- Locate the fibroid targeted for treatment on the ultrasound image.
- Determine the location of the tip of the Handpiece where it should enter the fibroid on the ultrasound image. Place the tip of the Handpiece at a location on the patient's abdomen aligned with the targeted entry point on the fibroid.
- At this point, the Guidance can be used to help confirm this location by adjusting the angle of the Handpiece so that the trajectory lines go through the targeted area on the ultrasound image and the purple target zone lines become visible on the image, indicating alignment with the target.
- Advance the tip of the Handpiece through the abdomen and into the abdominal cavity.
- Ensuring that the purple target zone remains located on the targeted entry point on the fibroid, advance the Handpiece until the tip is at the serosa of the uterus viewed on the laparoscopic monitor.
- After the tip penetrates the serosa, view image on the ultrasound monitor. Corrections to the path of the tip must be made using ultrasound imaging. Inserting the tip into the fibroid and deploying the electrode array must be done under ultrasound visualization only.
- Continue into the fibroid until the point of the tip is approximately 1 cm into the fibroid.
- For fibroids less than 1.5 cm in diameter:
  - If the fibroid is 1 cm or less, press the foot pedal (yellow) to ready the system for an ablation, then press it again to start RF.
  - If the fibroid is 1.5 cm in diameter, deploy slightly (about .2 cm) until the expected ablation size on the screen shows a 1.5 cm ablation size. Then press the foot pedal (yellow) to ready the system for an ablation, then press it again to start RF.
  - The ablation time will count up. When it reaches the correct time, a "Finished" tone will be heard.
  - Once the tone is heard, press the foot pedal (yellow) to stop the RF energy.



**WARNING: Do not advance, reposition or rotate Handpiece when electrode arrays are deployed.**

- For fibroids greater than 1.5 cm in diameter:
  - Deploy the electrode array until the distal point of the center needle is approximately 1 cm away from the distal edge of the fibroid.
  - Read the amount of deployment on the handpiece handle. Adjust the deployment until it is on a centimeter or half centimeter mark.
  - Confirm that the deployment displayed on the screen matches the deployment on the Handpiece handle.
  - Press the Foot pedal (yellow) once to ready the system for ablation, then press again to start RF.
  - The system will display the Ramp icon signifying that the temperature is rising to the target temperature of 95°C.

- When the temperature gets to 95°, a tone will sound signifying that target temp has been reached. The the timer will begin to count up.
- When it reaches the correct time, a "Finished" tone will be heard.
- Once the tone is heard, press the foot pedal (yellow) to stop the RF energy.
- To shut off RF energy, depress the foot pedal (yellow).
- The most important predictor of the completeness of the ablation is having reached the desired target temperature for the prescribed amount of time at set deployments of the electrodes of the Handpiece. For more information and guidance, see §11 and §12.
- Retract the Handpiece's electrode arrays and move to the next fibroid. Continue until all the fibroids have been treated.
- Immediately following a completed ablation, the user is ready to cauterize the Handpiece tract.
- When the Handpiece is removed, perform Coag as described in §9.6.

#### 10.12. Operation of System During Coag

- Retract the Handpiece's electrode arrays completely by sliding the electrode array knob to its mechanical stop.
- Depressing the right foot pedal (blue) activates the Ready Coag. The settings allow for 1-20 (power level), and default is always set to 12 or the last setting chosen.

**WARNING: Always verify that the electrode arrays are retracted fully before withdrawing the Handpiece to avoid patient injury!**

- The Handpiece tip should be allowed to cool for 60 seconds after the ablation has stopped prior to removing it from the target tissue
- When ready to Coag, turn the RF energy on by pressing and holding the foot pedal (blue). The user judges proper coagulation by visual observation and experience.
- Observe the Coag on the laparoscope and pull back the device slowly until the tip is visible.
- Turn off RF power when track coagulation is completed by releasing the foot pedal (blue).
- Note: During Coag mode the user may experience char on the tip. A sterile disposable wipe moistened with 70/30 isopropyl alcohol may be used to clean the trocar tip. Dry the Trocar or allow it to evaporate before use. Before Handpiece insertion into peritoneal cavity, deploy electrode arrays and inspect.

#### 10.13. After the Procedure

- Disposable items should be disposed of according to normal hospital practices. Additionally, follow local governing ordinances and recycling plans regarding disposal or recycling of disposable items.
- Clean the non-disposable Acessa components according to the directions in §6 or in their Instructions for Use.

#### 10.14. Shutting Down the System

- To shut down the system, press the On/Standby button for approximately 4 seconds. Then turn the switch on the rear panel to Off (O).

**11. Special Considerations: General Ablation Procedures**

**11.1. Highly Vascularized Tissue**

If all connections are verified to be correct and desired temperatures continue to not be obtainable, the electrode arrays may have been deployed into a highly vascular area. Consider withdrawing the electrode arrays (if deployed) into the Handpiece and then rotating or repositioning the Handpiece.

**11.2. One or More Electrode Arrays in a Duct or Vessel**

If one or more Electrode temperatures reads much lower than the rest of the temperatures, the electrode array may be in or near a vessel or duct. To correct this condition, stop the delivery of RF energy by depressing the foot pedal. Fully retract the electrode arrays (if deployed), then rotate the Handpiece. Redeploy the electrode arrays, and restart the ablation by depressing the foot pedal again.

**11.3. Ablation of Dense or Calcified Fibroid Tissue**

Incremental advancement of the electrode arrays will aide in penetrating dense tissue. With Console set for temperature control and the Handpiece tip placed at the required depth for ablation, activate RF until target temperature is reached. Deploy the electrode arrays ½ cm and maintain this deployment until target temperature is reached. Continue with ½ cm to 1 cm deployment increments, reaching target temperature, until the last deployment is achieved (e.g., 5 cm deployment in muscle for 12 minutes creating a final ablation size of 5.6 cm by 4.4 cm). Maintain target temperature for stated target time for the last deployment stage to allow for complete tissue destruction.

If a fibroid is densely concentrated with calcium to the degree that there is abnormal resistance to insertion and/or rotation of the Acessa Handpiece tip (with electrode arrays fully retracted):

- discontinue rotating the device
- withdraw the Handpiece by pulling back along the path of insertion (electrode arrays retracted, do not rotate)
- re-enter the fibroid from another direction (ideally where the sonographic appearance demonstrates fewer/smaller calcium deposits).

Once the tip of the Handpiece is positioned in a desired location, if deployment of the electrode arrays is impeded by calcium deposits:

- Fully retract the electrode arrays and carefully rotate the device 3-5 degrees, then re-attempt deployment (repeat the retraction/slight rotation/deployment method if necessary until deployment is achieved).
- deployment cannot be achieved in spite of repeated efforts, fully retract the electrode arrays and attempt deployment with the Acessa Handpiece tip repositioned in another location within the fibroid.

**12. Ex-Vivo Studies**

**12.1. Ex-Vivo Studies**

Bench top studies were conducted using Bovine liver. The purpose of these studies was to characterize the ablation size when created with different deployments for varying amounts of time and at different power and temperature settings. Generally, for a given time, increasing the target power or temperature tends to produce larger ablation sizes. For a given target power or temperature, increasing the time tends to produce larger ablation sizes.

**12.2. Representative Ablation Shape per Deployment**

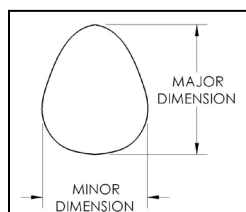

\*Major dimension = length or axial length

\*Minor dimension = width

### 12.3. Results from Ex-Vivo Bovine Liver Studies

The system uses a power control mode for ablating target zones less than 1.5 cm in diameter. The electrode array is not deployed when using power control mode and the ablation time is 1 minute or less. The following table shows the average ablation zone and the recommended times at 0.0 deployment using an ex-vivo bovine liver at 15 W power.

TISSUE: Liver		CONTROL MODE: Power		POWER: 15 W	
ABLATION SIZE (cm)		DEPLOYMENT (cm)	TIME	POWER	
MAJOR DIAMETER	MINOR DIAMETER				
1.0 ± 0.11	0.8 ± 0.09	0.0	15 sec	15W	
1.5 ± 0.06	1.2 ± 0.14	0.0	1 min	15W	

### 12.4. Representative Ablation Sizes in Ex-vivo Bovine Liver with Settings in Temperature Control

The system uses a temperature control mode for ablating target zones greater than 1.5 cm in diameter, and with the electrode array deployed. The following table shows the average ablation zone and the recommended times and deployments, using an ex-vivo bovine liver with a target temperature of 95°C.

TISSUE: Liver		CONTROL MODE: Temperature		TEMPERATURE: 95°C	
ABLATION SIZE (cm)		DEPLOYMENT (cm)	TIME	TARGET TEMPERATURE	
MAJOR DIAMETER	MINOR DIAMETER				
1.9 ± 0.06	1.7 ± 0.12	0.5	30 sec	95°C	
2.1 ± 0.15	1.9 ± 0.15	1.0	1 min	95°C	
2.7 ± 0.05	2.3 ± 0.11	1.5	2 min	95°C	
3.3 ± 0.11	2.7 ± 0.25	2.0	3 min	95°C	
3.9 ± 0.11	3.0 ± 0.21	2.5	4 min	95°C	
4.2 ± 0.32	3.4 ± 0.23	3.0	5 min 30 sec	95°C	
4.8 ± 0.32	3.7 ± 0.64	3.5	7 min	95°C	
5.2 ± 0.04	4.3 ± 0.50	4.0	7 min 30 sec	95°C	
5.6 ± 0.38	4.4 ± 0.38	4.5	8 min	95°C	
6.0 ± 0.35	5.0 ± 0.69	5.0	12 min	95°C	

## 13. Clinical Studies – Fibroids

Prospective, non-randomized, longitudinal Phase II studies using the Acessa System were conducted at two separate centers to establish early safety and effectiveness data. A total of 69 premenopausal females (average age 42.1 ± 5.5 years); the average reproductive status was gravida 2.8 ± 2.0 and para 2.1 ± 1.6. At the time of screening, 81% of the subjects reported having regular menstrual cycles, and 77% reported having heavy-to-very heavy bleeding volume. Nearly 85% of the subjects reported bleeding between periods. Fibroid symptoms of menorrhagia and dysmenorrhea were found in 98% and 38% of the subjects, respectively. A total of 285 fibroids were ablated (median = 3) with one patient having 20 fibroids treated.

**Results:** The mean uterine volume at baseline was 204.4 cm<sup>3</sup>. At 6 months and 12 months post-treatment, the mean uterine volume was significantly reduced to 155.0 cm<sup>3</sup> (p= 0.012) and 151.4 cm<sup>3</sup> (p = 0.009), respectively. The percent of subjects demonstrating reduced uterine volume in contrast to baseline was 82.2%, 80.0%, and 79.3% at the 3-, 6-, and 12-month visits, respectively. At baseline, 77% of subjects reported heavy to very heavy bleeding prior to the treatment. After 12 months post-treatment, 3.5% (p<0.0001) reported heavy to very heavy bleeding based on the patient reported survey. The UFS-QOL questionnaire was administered at baseline and at all follow-up visits. The mean percent improvement in Symptom Severity Scores from baseline to post-treatment was 59.6% at 3 months, 65.0% at 6 months, and 79.0%, at 12 months. The mean percent change in HRQL Scores from baseline to 3 months post-procedure was 41.6%, from baseline to 6 months post-procedure was 39.7%, and from baseline to 12 months post-procedure was 42.9%. Overall, sixty-five subjects (94.2%) reported improved Symptom Severity Scores and sixty-one subjects (88.4%) reported improved HRQL Scores. In terms of safety, there was only one (1.4%) serious adverse event (i.e., abdominal wall hematoma), which was determined to be related to the procedure. It was treated by laparotomy and vessel ligation.

The device pivotal (Phase III) study included the treatment of 137 women with symptomatic fibroids including menorrhagia. A total of 11 centers in the United States (9 centers) and Latin America (2 centers) and 13 investigators participated in the study:

**13.1. Study Design**

This prospective, multicenter, longitudinal, single-arm, paired-comparison, interventional study was designed to evaluate the efficacy and safety of radiofrequency ablation (RFA) treatment of symptomatic uterine fibroids with the Acessa System. All study subjects who underwent uterine fibroid ablation with the Acessa System were expected to continue to participate in the study for 36 months following the procedure. Primary endpoint analysis was conducted at one year post treatment.

**13.2. Study Objectives****13.2.1. Primary Objectives**

The primary objectives of the study were to confirm the safety and efficacy of the Acessa System for the treatment of symptomatic uterine fibroids.

**13.2.2. Secondary Objectives**

The secondary objectives of the study were to evaluate the change in uterine and fibroid volume, symptom severity, health related quality of life, general health status, and subject satisfaction at 12 months post treatment compared to baseline.

**13.2.3. Inclusion and Exclusion Criteria**

Subjects were included if they were 25 years of age or older, desired uterine preservation but did not desire current or future childbearing, had symptomatic uterine fibroids, had a uterine gestational size  $\leq 14$  weeks,  $\leq 6$  treatable fibroids, with no single fibroid exceeding 7 cm in any diameter as measured by transvaginal ultrasound and a total uterine fibroid volume that did not exceed 300 cc on ultrasound or contrast-enhanced MRI evaluation. In addition, the subject was required to have clinical menorrhagia, as indicated by menstrual blood loss of  $\geq 160$  mL to  $\leq 500$  mL along with a 3-month history of menorrhagia within the last 6 months. Subjects were required to have a normal coagulation profile, a normal Pap smear, and pass a preoperative health examination (American Society of Anesthesiologists [ASA] physical status I-III). Subjects were excluded from the study if they had contraindications for laparoscopic surgery and/or general anesthesia, had undergone pelvic radiation or had a gynecologic malignancy or premalignancy within the past 5 year, had a non-uterine pelvic mass, had prior pelvic surgery that was known to cause significant intra-abdominal adhesions or had a history of, or active, pelvic inflammatory disease, had undergone endometrial ablation, uterine artery embolization, uterine artery ligation, or any other uterine-preserving technique for reduction of menstrual bleeding, had taken any gonadotropin-releasing hormone (GnRH) agonist within 3 months prior to the screening, had an implanted intrauterine or fallopian tube device for contraception that could not be or would not have been removed 1 month prior to treatment, or if they required elective concomitant procedures. Peri-menopausal and menopausal women were excluded in the study due to the requirement for collection of used catamenial products. Pregnant or breastfeeding women, women with dysfunctional uterine bleeding or chronic pelvic pain, adenomyosis, or endometriosis were excluded. Women with cervical myomas, pedunculated subserosal fibroids or "type zero" (completely intracavitary) submucous fibroids were also excluded.

**13.3. Study Demographics**

A total of 137 women were enrolled and treated in the Acessa Health pivotal study. The study demographics are shown in the table below.

*Demographics*

Variable	Statistic/Response	All Sites (N=137)
Age (years)	n	137
	Mean (SD)	42.4 (4.72)
	Median	43.0
	Min, Max	31, 55
Race	White or Caucasian	62 (45.3%)
	Black or African American	46 (33.6%)
	Asian	2 (1.5%)
	Other	27 (19.7%)
Ethnicity	Hispanic or Latino	62 (45.3%)
	Not Hispanic or Latino	75 (54.7%)

**13.4. Fibroid Symptoms and Characteristics Reported at Baseline – All Subjects**

As required by the protocol, all 137 of the subjects reported menorrhagia at baseline and that they had experienced 3 or more heavy periods in the last 6 months. Other than menorrhagia, dysmenorrhea (51.1%), backache (44.5%), increased abdominal girth (43.8%), and pelvic pressure (43.8%) were the most commonly reported fibroid-related symptoms at baseline.

*Reported Fibroid Symptoms at Baseline*

Variable	Response	(N=137)
Fibroid Symptoms	Menorrhagia	137 (100.0%)
	Dysmenorrhea	70 (51.1%)
	Backache	61 (44.5%)
	Increased Abdominal Girth	60 (43.8%)
	Pelvic Pressure	60 (43.8%)
	Urinary Frequency/Retention	52 (38.0%)
	Sleep Disturbance	48 (35.0%)
	Dyspareunia	45 (32.8%)
	Uterine Pain	41 (29.9%)
	Localized Pain	23 (16.8%)
	Other	13 (9.5%)

**13.5. Treatment**

All 137 enrolled subjects were treated using the following principles of volumetric thermal ablation:

- 1) The Handpiece tip was placed approximately 1 cm into the fibroid,
- 2) Deployment of the needles was not necessary unless the diameter of the fibroid was ≥ 2 cm,
- 3) In cases where deployment of the electrode array was performed, the array was deployed so that the electrode tips were at least 1 cm away from the fibroid margin in all three planes.

Laparoscopic ultrasound guided the placement of the Handpiece, deployment of the electrode array, and confirmation of the 1 cm margins before each ablation. The following chart was used to guide the ablation:

Deployment	0	0	0.5	1	1.5	2	2.5	3.5	4.5	5
Setting	15 Watt	15 Watt	100°C	100°C	100°C	100°C	100°C	100°C	100°C	100°C
Target Time	15 sec <sup>1</sup>	1 min <sup>2</sup>	1 min	30 sec	2 min	3 min	4 min	7 min	8 min	12 min

<sup>1</sup> For 1 cm fibroids

<sup>2</sup> For 1.5 cm fibroids

For larger fibroids or fibroids that were more irregular or oval, overlapping ablations were used. In such cases, the smallest diameter of the fibroid determined the degree of Handpiece insertion and the length of deployment of the electrode array. Often, the same serosal puncture was used to treat overlapping ablations in one fibroid or to treat other fibroids in close proximity.

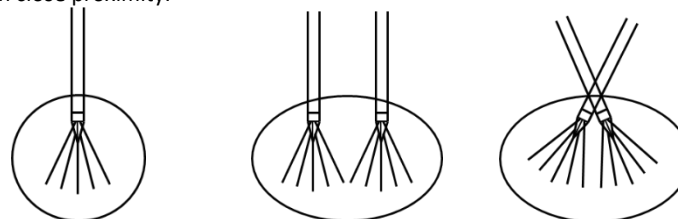

Appropriate tip placement for spherical, irregular, or oval fibroids

Once an ablation was initiated, the serosa overlying the fibroid was directly observed with the laparoscope. Once all fibroids were treated appropriately, the array was retracted and the track was coagulated using “coag mode.”



*Types and Number of Fibroids Treated in the Study*

Variable		N = 135 <sup>2</sup>
<b>Number of fibroids treated per patient</b>		<b>1 to 29</b>
<i>Mean number of fibroids treated per patient</i>		5
<i>Median number of fibroids treated per patient</i>		4
<b>Number of total fibroids treated within the study</b>		<b>674</b>
<i>Types of fibroids<sup>1</sup></i>	<i>Intramural</i>	347
	<i>Subserosal</i>	193
	<i>Submucosal</i>	164
	<i>Transmural</i>	39
	<i>Missing Type</i>	18
<i>Location of fibroids<sup>1</sup></i>	<i>Fundal</i>	148
	<i>Mid Uterus</i>	41
	<i>Lower Uterine</i>	118
	<i>Anterior</i>	235
	<i>Posterior</i>	236
	<i>Left</i>	144
	<i>Right</i>	153
	<i>Broad Ligament</i>	2
	<i>Missing Location</i>	2

<sup>1</sup>A fibroid may be in more than one location or be of more than one type.

<sup>2</sup>Full analysis set excludes two subjects who did not meet the bleeding criteria

### 13.6. Results of the Pivotal Study

Of the 137 subjects enrolled and treated under this protocol, 124 (90.5%) were considered "evaluable" in terms of their 1) ability to provide a menstrual blood loss assessment, 2) lack of concomitant disease that affects the menstrual cycle, 3) baseline menstrual blood loss was within protocol inclusion limits. The table below shows the subject disposition at 12 months post treatment.

#### *Subject Disposition at 12 Months Post Treatment*

	n (%)
<b>Total Treated</b>	<b>137 (100%)</b>
Evaluable for Menstrual Blood Loss Using Alkaline Hematin*	124 (90.5%)
Withdrew prior to 12 months*	2
Lost to follow up*	1
Pregnant	3
Menstrual blood loss baseline outside protocol inclusion limits	2
Hashimoto's Disease	1
Menopause/amenorrhea	4

\*The primary full analysis set (PFAS, N=127) for bleeding relief is composed of subjects who withdrew, were lost to follow up, or are evaluable.

#### *Subject Disposition at 24 and 36 Months Post Treatment*

	n (%)
<b>Total Evaluable at 12 months</b>	<b>124 (100%)</b>
Withdrew or lost to follow up between 12 and 24 months	3
Withdrew or lost to follow up between 24 and 36 months	2
Pregnant	1
12-24 month reintervention	6
24-36 month reintervention	4
Elective endometrial ablation	1

\*3 additional subjects underwent a reintervention after the 36 month visit was completed.

### 13.7. Safety

*Summary of Treatment-Emergent Adverse Events by Relationship to the Device, Laparoscopic Procedure, and/or Classified as Serious.*

Urinary tract infection, which was reported in 7 of the 137 subjects (5.1%) was the most commonly reported adverse event during the three year follow up followed by bacterial vaginitis (6/137, 4.4%), influenza (4/137, 2.9%), pharyngitis (4/137, 2.9%), lower abdominal pain (4/137, 2.9%) and dizziness (4/137, 2.9%).

Adverse Events Classified as Possibly, Probably, or Definitely related to the Device – Pelvic Abscess, serosal colon injury, lower abdominal pain superficial uterine serosal burn and post-procedural hemorrhage were each reported as single adverse events for a total device-related adverse event rate of 3.6%.

Adverse Events Classified as Possibly, Probably, or Definitely related to the Procedure - Lower abdominal pain, dysuria and dysmenorrhea were each reported in 3 of the 137 subjects (2.2%). Procedural pain, procedural vomiting, dizziness and hypoesthesia were each reported in 2 of the 137 subjects (1.5%) Cystitis, pelvic abscess, wound infection, oral hypoesthesia, vomiting, pain, post-operative anemia, uterine serosal burn, serosal colon injury, post procedural hemorrhage, post-procedure shivering, incisional rash, contusion, incisional site hemorrhage, wound hematoma, spontaneous abortion, hematuria, premenstrual syndrome, atelectasis, seroma, and endometritis were each reported as single adverse events (0.7%).

Adverse Events Classified as Serious -Seventeen of the adverse events occurring in fifteen subjects were considered serious; atelectasis (1 subject, 0.7%), chest pain (2 subjects, 1.5%), viral infection with otitis externa (1 subject, 0.7%), pyelonephritis (1 subject, 0.7%), uterine hemorrhage resulting in anemia and requiring blood transfusion (1 subject, 0.7%), Achilles tendon rupture and intervertebral disc repair (1 subject, 0.7%), laceration in serosa of colon (1 subject, 0.7%), spontaneous abortion (1 subject, 0.7%) pelvic abscess (1 subject, 0.7%), hemiparesis (1 subject, 0.7%), dyspnea (1 subject, 0.7%), motor vehicle accident, (1 subject, 0.7%), anemia, resulting in blood transfusion following Cesarean delivery, (1 subject, 0.7%), shortness of breath and pulmonary embolism, (1 subject, 0.7%) postoperative anemia following a reintervention (hysterectomy), and cerebrovascular accident (1 subject, 0.7%). Of these serious adverse events, only the pelvic abscess and the serosal colon injury were considered to be both device and procedure related. Additionally, the atelectasis was considered definitely related to the procedure and the spontaneous abortion and anemia were possibly related to the procedure.

### 13.8. **Efficacy**

*Menstrual Blood Flow as Assessed by Alkaline Hematin (AH):* In the evaluable subjects (n=124), the mean reduction in menstrual blood flow at 12 months post treatment was 103.6 ml. One hundred four of the 124 (83.9%) evaluable subjects experienced a reduction in bleeding at 12 months post treatment. Nineteen of the 124 subjects (15.3%) experienced an increase in bleeding at 12 months post baseline. When including the subjects lost to follow up as treatment failures, 40.2% (95% CI 31.6% - 48.7%) met the protocol criterion for bleeding relief (defined as  $\geq 50\%$  reduction in menstrual bleeding at 12 months post-treatment) though this did not meet the pre-specified study hypothesis that the lower bound of the 95% CI would be  $\geq 45\%$ .

### 13.9. **Surgical Reintervention Rate**

There was 1 subject (1/127, 0.8%) in the primary full analysis set (PFAS) who had a surgical reintervention (UAE) for bleeding after she withdrew from the study but prior to 12 months of follow up. The study did not include a prospectively developed hypothesis test for the 24 or 36-month surgical reintervention rate. The 24-month status has been documented on all of the 124 subjects in the PFAS who entered their second year of follow up. Three subjects were lost to follow up in the second year (3/124, 2.4%) and six of the remaining subjects (6/121, 5.0%) reported a surgical reintervention for fibroid-related bleeding between 12 and 24 months (4 hysterectomies and 2 hysteroscopic myomectomies). One subject reported an endometrial ablation at 16 months for heavy bleeding with no evidence of fibroids and one additional subject became pregnant. One hundred thirteen subjects in the PFAS entered their third year of follow up. Four subjects underwent a hysterectomy (4/113, 3.5%) and two were lost to follow up prior to the 36 month visit. An additional three subjects (3/107, 2.8%) had hysterectomies after undergoing their 36 month visit. In total, 14 subjects have undergone surgical reintervention for fibroid-related bleeding for a cumulative reintervention rate of 11.0%\*

\*based on Kaplan-Meier statistical procedure

### 13.10. **Uterine and Fibroid Volume**

RFA treatment resulted in a reduction from baseline in total uterine and fibroid volume, as assessed by pretreatment and post treatment contrast-enhanced MRI, at 3 and 12 months post treatment. At 12 months post treatment, the mean reduction in uterine volume (n=128) was 25.1% and the mean reduction in fibroid volume (n=119) was 44.3%.

Percent Change From Baseline in Total Uterine and Fibroid Volume at 3 and 12 Months Post treatment Based on Preoperative and Postoperative MRI Assessments

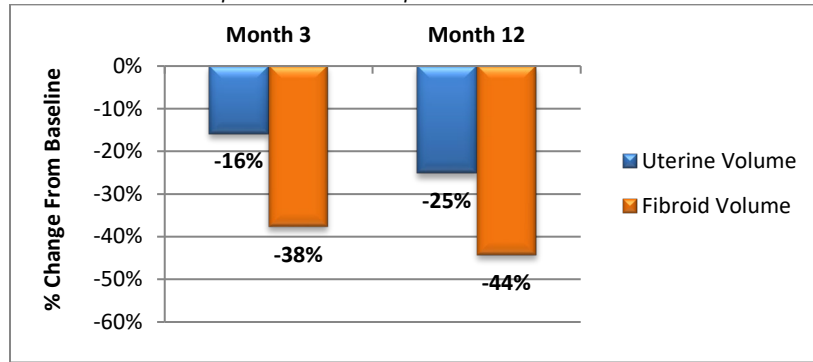

13.11. UFS-QOL Scores

Mean Health-Related Quality of Life (HRQL) scores and Symptom Severity Scores (SSS) improved significantly from baseline to 3 months, then remained similar at all intervals between 3 and 36 months post treatment.

UFS-QOL Symptom Severity and HRQL Scores at Baseline and at 3, 6, 12, 24, and 36 Months Post Treatment

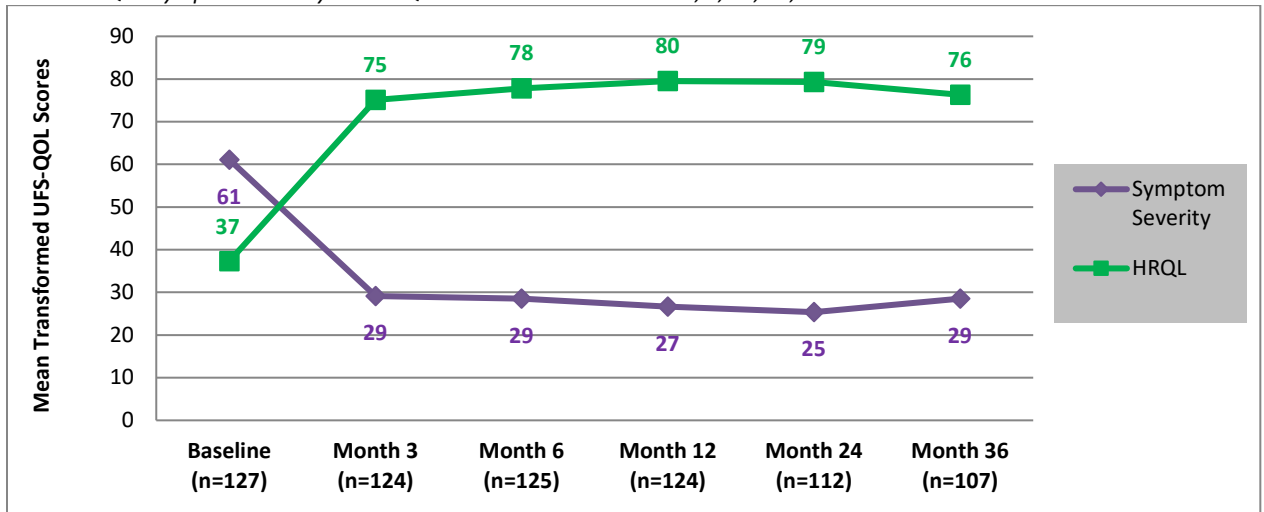

UFS-QOL Concern, Activities, Energy/Mood, Control, Self-Consciousness, and Sexual Function Scores at 3, 6, 12, 24, and 36 Months Post Treatment

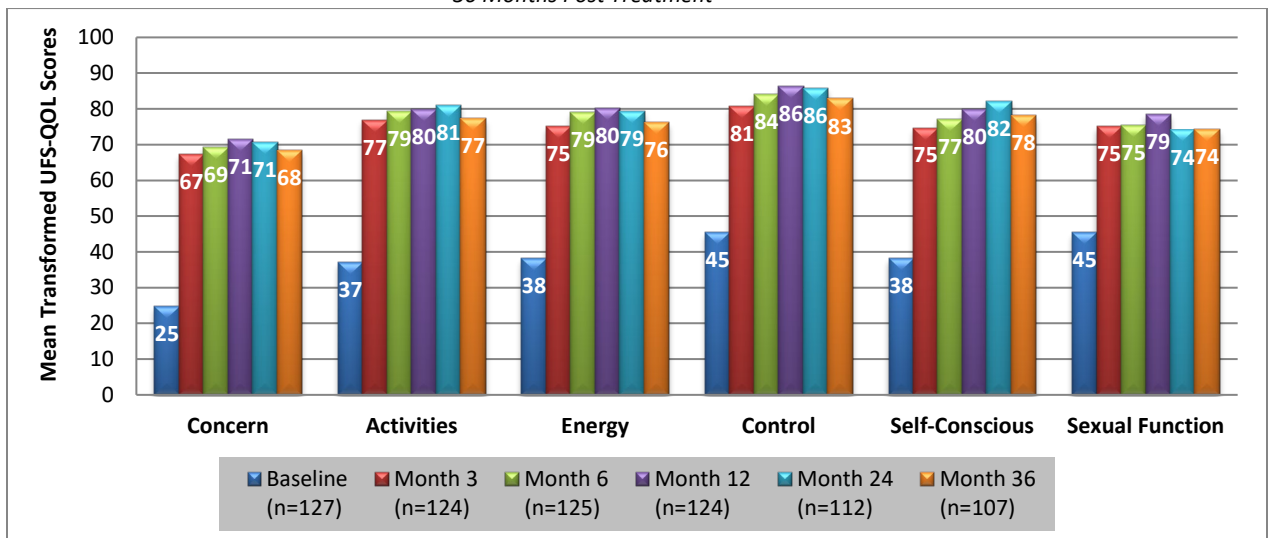

**13.12. EQ-5D Health State Score**

The EQ-5D score ranges from 0 to 100. An increase in the score post treatment indicates less disease burden.

*EQ-5D Scores at Baseline and at 3, 6, 12, 24, and 36 Months Post Treatment*

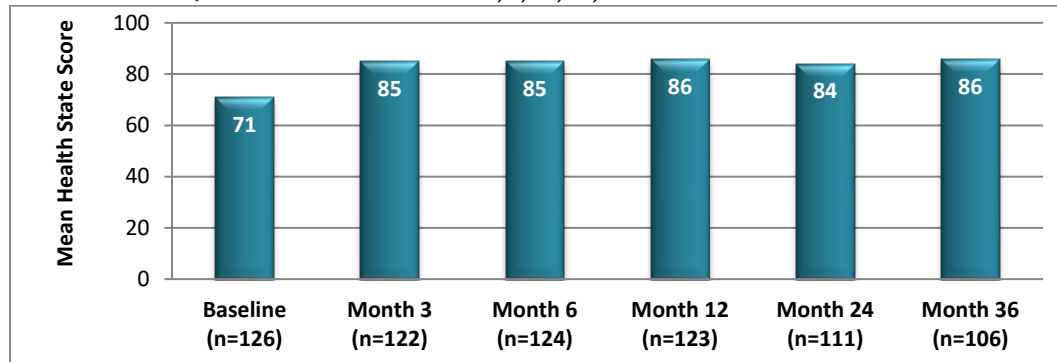

**13.13. Overall Treatment Effect (OTE) Survey**

The results of the OTE surveys showed that 94% of the subjects responded that they were very satisfied, moderately satisfied, or somewhat satisfied with the treatment. At 12-months post treatment, 98% of the subjects reported that they would probably or definitely recommend the procedure to their friends with the same health problem. When asked about effectiveness of the treatment, at least 94% of the subjects responded that the treatment had been somewhat, moderately, and very effective in eliminating their symptoms.

*OTE Survey at 12 Months Post Treatment*

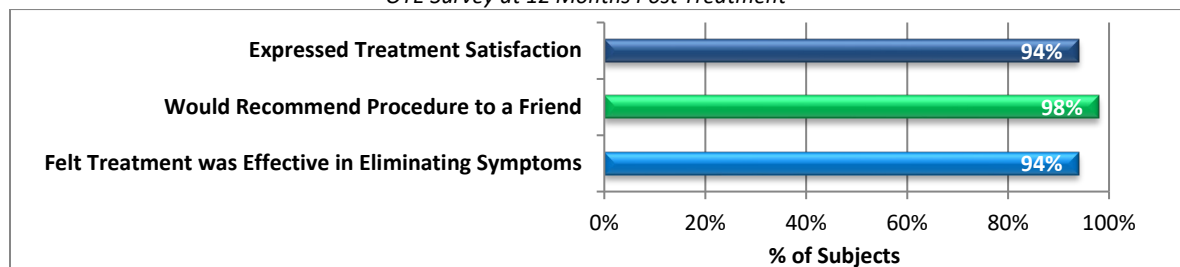

**13.14. Data regarding return to work and return to normal activities**

A total of 88 subjects reported that they were working. Subjects returned to work in a median of 5 days and all subjects reported that they returned to normal in a median of 9 days. Ninety-six percent of the subjects in the Acessa Health study were treated on an outpatient basis.

**13.15. Data regarding pregnancy**

Subjects recruited in the pivotal trial were to have completed their childbearing and were counseled to practice contraception. Despite this requirement, three subjects became pregnant within one year following the RF treatment and one subject became pregnant in the second year of follow up. One pregnancy resulted in a spontaneous abortion in the first trimester, one progressed normally resulting in a vaginal delivery, and two subjects had a C-section at 37 weeks due to hypertension (n=1) or gestational diabetes with hypertension (n=1). The latter C-section resulted in anemia which required several post-operative blood transfusions (see Safety Section 12.6.1). Patients should be counseled that there are limited data regarding pregnancy following RF ablation of fibroids.

**13.16. Data regarding calcified fibroids**

Seven subjects (5.1%) had one or more calcified fibroids that were treated during the RF ablation procedure. Calcified fibroids did not appear to impact the physician’s ability to insert the tip of the Handpiece but the data are minimal regarding calcified fibroids at this time.

**13.17. Therapeutic medications at 24 and 36 months post-treatment**

One subject (1/124, 0.8%) reported taking Depo-Provera for vaginal bleeding at Month 24. Three subjects (3/124, 2.4%) reported taking progesterone or GnRH agonist for vaginal bleeding prior to surgical reintervention within 12-24 months post treatment. Between the 24 and 36 months visits, one subject (1/112, 0.9%) reported taking oral contraceptives, one subject (1/112, 0.9%) reported taking Depo-Provera prior to her reintervention, and one subject (1/112, 0.9%) reported taking oral progesterone.

**14. Postmarket Surveillance Study – TRUST (Treatment Results of Uterine Sparing Technologies)****14.1. Summary of the Post-Approval Study Methods****14.1.1. Study Objective**

The study objectives were to compare the rates of acute and near-term serious complications in the Acessa subjects to the acute and near-term treatment-related serious adverse event rates of the pivotal (pre-market) study.

**14.1.2. Study Design**

A multi-center, prospective, randomized, controlled, clinical trial, conducted at 11 sites in the U.S. and 3 sites in Canada.

**14.1.3. Study Population**

Premenopausal female patients  $\geq 18$  years old who had symptomatic fibroids, who desired uterine conservations, and who were indicated for a surgical intervention for their symptoms were enrolled in the study.

**14.1.4. Data Source**

Data were collected prospectively on each subject using dedicated case report forms that were source verified at all study visits.

**14.2. Key Study Endpoints****14.2.1. Primary Endpoint**

The primary endpoint was the overall rates of acute (within 48 hours post procedure) and near-term (between 2 and 30 days post procedure) serious complications in all GFA (Acessa) subjects compared to the acute and near-term treatment-related serious adverse event rates in the pivotal study.

**14.2.2. Secondary Endpoint**

The secondary endpoint was the incidence of serious complications per investigator-surgeon during training and post training.

**14.3. Total Number of Enrolled Study Sites**

14 sites in the United States and Canada enrolled participants in the study.

**14.4. Total Number of Enrolled Subjects and Follow-up Rate**

A total of 110 participants were enrolled. Five (5) subjects withdrew or were withdrawn prior to treatment. 105 subjects were treated per protocol between April 25, 2014 and October 2, 2017.

**Table 14.1** shows that of the 105 treated subjects, 100 completed both the 48-hour and 30-day follow up visits.

**Table 14.1** Number and percentage of subjects reaching each designated study phase

Number of Subjects Treated	Number and Percentage of Subjects With 48-hour Data (Median=2 days)	Number and Percentage of Subjects With 1 Week Data (Median=7 Days)	Number and Percentage of Subjects With 30-day Data (Median=37.5 days)	Number and Percentage of Subjects Who Have Completed the 522 Requirements (48 hr and 30 Days)	Number and percentage of subjects lost to follow up before 30 days
105/105 (100%)	101/105 <sup>1</sup> (96.2%)	100/105 (95.2%)	104/105 <sup>2</sup> (99.0%)	100/105 (95.2%)	1/105 <sup>2</sup> (0.95%)

<sup>1</sup>Two subjects missed the 48-hour visit but reported no serious complications at the 1-week visit and two additional subjects missed

both the 48-hour visit and the 1-week visit but were followed by investigator on at the 30-day visit.

<sup>2</sup>One (1) subject was lost to follow up after the 48-hour visit but reported no serious complications at that time. Note that percentage is based on total number of subjects treated.

**14.5. Study visits and length of follow up**

After passing screening, subjects' baseline and procedure data were recorded. Subjects were followed at 48 hours (window 24-72 hours), 1 week (window 5-12 days), and 1 month (window 4-8 weeks) post treatment to assess for acute and near-term serious complications.

## 14.6. Summary of the Post-Approval Study Results

### 14.6.1. Final safety findings (key endpoints)

There were no significant differences between the acute serious events arising from the procedures performed by the investigators in the pivotal study compared to those of the investigators in the postmarket surveillance study.

**Table 14.2** provides a summary of serious complications reported (primary endpoint) and incidence of complications related to the investigator-surgeon (secondary endpoint) in the postmarket surveillance study. There were no acute serious complications. There was only one (1) serious complication (fever of unknown origin requiring hospitalization) which was categorized a “near-term” as it occurred more than 48 hours after the procedure.

**Table 14.2 Overall Summary of Serious Complications<sup>1</sup> Related to Subject Safety; Timing of Serious Complications, and Incidence by Investigator-Surgeons Trained (Postmarket Surveillance Study)**

Category	Number (%)
Subjects Reporting at Least One Serious Complication (Subsets Below)	1/105 (0.95%)
• Subjects Reporting at Least One Serious Anesthesia-Related Complication	0/105 (0.0%)
• Subjects Reporting at Least One Serious Abdominal Entry Related Complication	0/105 (0.0%)
• Subjects Reporting at Least One Serious Uterine Related <sup>2</sup> Complication	1/105 (0.95%)
Rate of Acute Serious Complications (occurring within 48 hours of Treatment)	0/101 (0.0%) <sup>3</sup>
Rate of Near-Term Serious Complications (occurring between 2 and 30 days post treatment)	1/104 (0.96%) <sup>3</sup>
Incidence of serious complications per investigator-surgeon during training and post training.	1/29, 3.4%

<sup>1</sup>Serious complications are serious adverse events that are treatment related, i.e., related to anesthesia, abdominal entry, or uterine entry, manipulation, or treatment during the procedure.

<sup>2</sup>Uterine related - Related to uterine entry, manipulation, or treatment

<sup>3</sup>Percentages are based on the number of subjects who participated in that follow-up visit.

For the acute serious complication rate, the null hypothesis was that the acute serious complication rate for the Acessa procedure is no different than the observed acute treatment-related SAE rate of 1.46% in the pivotal study. The alternative hypothesis is that the acute serious complication rate is different. Setting a two-sided alpha level to 0.05 and the sample size to 100, the power to detect a difference in the acute serious complication rate is at least 0.80 if the true acute serious complication rate is at least 6.7%

For the near-term serious complication rate, the null hypothesis is that the near-term serious complication rate is no different than the observed near-term treatment-related SAE rate of 0.73% in the pivotal study. The alternative hypothesis is that the near-term serious complication rate is different. **Table 14.3** provides a comparison of the pivotal study (premarket) and postmarket surveillance serious complications. In the pivotal study, there were two (2) acute serious complications (2/137, 1.46%) compared to no acute serious complications in the postmarket surveillance study (0/101, 0.0%). Both studies reported one (1) serious complication in the near-term follow up phase for a rate of less than 1% in each study. Therefore, both null hypotheses are accepted.

**Table 14.3 - Serious Events Compared: Premarket vs. Postmarket Data (Primary Endpoint)**

Serious Events/Complications Related to Device or Procedure - ACUTE/48 hours (Window 24-72 hours)	Pivotal Study (Premarket) Total N in Safety Group = 137			Postmarket Surveillance Total N in Safety Group = 105		
	N	Event	Rate	N	Event	Rate
Related to Anesthesia?	1	Atelectasis	0.73%	0	N/A	0%
Related to Abdominal Entry during procedure?	0	N/A	0%	0	N/A	0%
Related to Uterine Entry/Manipulation/Treatment	1	Colon laceration	0.73%	0	N/A	0%
Serious Events/Complications Related to Device or Procedure - NEAR TERM/30 days (Window 4-8 weeks)	N	Event	Rate	N	Event	Rate
Related to Anesthesia?	0	N/A	0%	0	N/A	0%
Related to Abdominal Entry during procedure?	0	N/A	0%	0	N/A	0%
Related to Uterine Entry/Manipulation/Treatment	1	Pelvic Abscess	0.73%	1	Fever of Unknown Origin	0.96%

#### 14.6.2. Study Strengths and Weaknesses

The target number of subjects was 100; however, the Sponsor allowed for a 5% over-recruitment to account for withdrawals, missed visits, and loss to follow up before 30 days. Each enrolling site contributed at least one (1) subject but no site contributed in excess of 22 subjects (21% of the total). Over 60% of the subject data come from the United States (U.S.). A weakness of this study is the small number of ethnic minority subjects, particularly Hispanic/Latin American women. **Table 14.4** provides the demographic data regarding the 105 treated subjects. The results of the postmarket surveillance study were consistent with results of the pivotal study, demonstrating the studies are reliable benchmarks for safety.

**Table 14.4:** Demographics of subject population

Variable		(N=105)
Age (Yrs)	Mean (SD)	470.5 (6.88)
	Median	40.0
	Min	21
	Max	54
Height (cm)	Mean (SD)	164.18 (8.007)
	Median	164.20
	Min	147.3
	Max	185.0
Weight (kg)	Mean (SD)	77.81 (19.432)
	Median	73.00
	Min	48.6
	Max	137.0
Ethnicity	Caucasian	43 (41.0%)
	Chinese	2 (1.9%)
	Korean	1 (1.0%)
	Black	39 (37.1%)
	Latin American	4 (3.8%)
	Japanese	0 (0.0%)
	Filipino	3 (2.9%)
	Aboriginal	2 (1.9%)
	South Asian	2 (1.9%)
	SE Asian	0 (0.0%)
West Asian	0 (0.0%)	

### 15. Potential Risks of Acessa ProVu System

Known risks associated with radiofrequency ablation of fibroids include: skin burn, mild intra-operative bleeding, transient urinary retention or urinary tract infection, adhesion formation, post-procedural discomfort (cramping, pelvic pain), and transient amenorrhea:

- The risk of skin burn from the dispersion of radiofrequency energy is minimal and is a common risk for electrosurgical procedures.
- Bleeding may be observed due to injury to blood vessels in the area that the sharp electrosurgical device is inserted and deployed. Hemorrhage may occur from thermal injury to large blood vessels in the area ablated.
- Urinary retention or urinary tract infection are common complications following bladder catheterization.
- The formation of adhesions (scar tissue formation) following laparoscopic surgery is an inherent risk to the procedure.
- Cramping or pelvic pain may be experienced after the procedure and may require non-steroidal anti-inflammatory drugs (NSAID) or other analgesic medication for relief.
- There is a possibility that transient amenorrhea may result from this or any surgical procedure due to the effects of surgery and anesthesia on hypothalamic function.

Additional potential risks include: infection, injury to adjacent structures, vaginal bleeding and temporary anemia, blood loss requiring transfusion or hysterectomy, pneumothorax, wound dehiscence, deep vein thrombosis and pulmonary embolus, treatment failure, and complications related to laparoscopy and/or general anesthesia, including death.

After radiofrequency ablation of fibroids, instrumentation of the uterine cavity should be performed with caution and only when absolutely necessary.

## 16. Patient Counseling

Symptomatic uterine fibroids can severely impact quality of life. Some medical therapies are available including surgical options. Women seeking uterine-sparing surgical intervention for fibroids should have an understanding of the potential benefits, risks and adverse events associated with the Acessa System and other available options.

There are surgical and anesthesia related risks that are common to all surgical procedures for fibroids, including injury to adjacent structures, amenorrhea, blood loss requiring transfusion, or hysterectomy. Although minimal, whenever radiofrequency energy is used in an operating room, there is a risk of skin burn from the dispersion of energy.

Use of the Acessa ProVu System offers a minimally invasive, low-risk technique to ablate fibroids while sparing the uterus. The system and the procedure provides benefits such as a reduction or elimination of uterine fibroid related symptoms, which includes menorrhagia, dysmenorrhea, dyspareunia, urinary frequency, and pressure pain, and return to normal activities.

See Section 13 for a full list of potential complications, adverse events, and benefits of the procedure.

## 17. Care and Maintenance

### 17.1. Software Upgrades and Installation

There is no installation required. Any software upgrades must be exclusively performed by Acessa Health.

### 17.2. Maintenance

The Console is designed for indoor use in a dry operating room/procedure room environment. The Console requires no maintenance or calibration by the user. The user should not remove the cover. Removal of unit cover voids the warranty. All issues or maintenance required must be referred to Customer Service at Acessa Health. Refer to §1 for applicable contact information.

### 17.3. Cleaning and Disinfecting the Console

The Console Foot Pedal, and Field Generators should be given reasonable care and be kept clean and sanitary. To clean the Console, Foot Pedal, and Field Generators wipe down the devices with a 70% isopropyl alcohol wipe. Clean surfaces until all visible soil is removed. Wipe critical areas such as the buttons and any other areas that may become soiled. After removing all visible, gross soil use a Super SaniCloth® 0.5%/55% (working solution) to wipe all surfaces. Make sure the surfaces remain visibly wet at room temperature for the minimum time specified by Super SaniCloth instructions. Remove any excess disinfectant solution using a soft lint-free cloth.

**WARNING: Electric shock hazard. Do not saturate the Acessa ProVu System with liquids. Do not allow liquids to run inside the unit. Do not immerse the Console in water. Shut off the Console, and disconnect power before cleaning/disinfecting. Do not sterilize the Console.**

**CAUTION:** Do not use abrasives, caustics, or mineral spirits. Use of these agents to clean the Console, or any of its accessories may cause damage and voids the warranty. All electrical connections must be air-dried before use.

### 17.4. Calibration Verification

There are no user calibration adjustments on the Console. The Console requires no calibration prior to use. Follow any procedures or tests (if any) required by the individual hospital policy. Once the Console is turned on, the software runs through a self-test verifying the functionality of the Console. If the Console fails the self-test, contact Customer Service at Acessa Health Inc.

## 18. Specifications

### 18.1. System Specifications

Type of Specification	Specification
Operating Modes	Constant Power, Constant Temperature, or Coag.
Max Output Power	200 W into 50 – 80 Ω. Max allowable power is reduced outside this resistance range. Note that typical body impedance is in the range of 50Ω to 80Ω.
Power Accuracy	Power accuracy over range of 20W to 200W is ±20%.
Temperature Measurement Accuracy	±4°C from 15°C - 125°C ±5°C below 15°C and above 125°C
Operating Frequency	460 kHz, ±5%
Operating Power	120 VAC ± 10%, 60 Hz ± 1 Hz, 6A, 450 VA 240 VAC ± 10%, 50 Hz ± 1 Hz, 3A, 450 VA Auto-Switching Power Supply



Type of Specification	Specification
Ablate Temperature	The system sets the Ablate Target Temperature to 95 °C.
Power Range - Temperature Control Mode	The system software shall limit the Ablate Power Target to the range 1 to 200 (W).
Power Control Mode	The system shall limit the Ablate Power Target to 15 W.
Coag Level	Coag Level Target is limited to the range of 1 to 20 with Level 12 as default.
Max Output Voltage	240 Vpeak into 100 Ω ablation, 350Vpeak into 300 Ω coagulation Note that coag output voltage can go as high as 550Vpeak for high impedance loads and momentary overshoot due to energy storage in passive filter components.
Accessories Rated Voltage	The ACESSA ProVu accessories are rated for the maximum peak output voltage as indicated. Only ACESSA accessories are to be used with the ACESSA ProVu System .
Fuses	Two 7.0 Amp 250 volt fuses (in the Power Entry Module on rear panel)
Dimensions	16.5” x 18.9” x 8.0” (width x depth x height) (41.9 cm x 48.0 cm x 20.3 cm)
Weight	30 lbs. (13.6 kg)
Controls	Main Power on/off, Standby on/off, RF on/off, System Settings
Displays	Standby Pushbutton Orange Standby Power On LED Target Temperature in °C Connected accessories Target timer in min:sec, Average temperature of all Handpiece thermocouples in °C Coag power level Hottest Pad thermocouples in °C, Expected ablation size (X & Y) Deployment in cm Ultrasound settings (Depth, Frequency, Gain, Focus)
Connections	Foot Pedal Port, Handpiece Port, Pad Port, Transducer Port, Transducer Sensor Port, Field Generator Port, USB Port, Video Port (HDMI), Power Entry Module (with internal fuses)
Protection	Class I, – Type BF Applied Part - Rated for ordinary, Continuous Operation. Ingress of water classification: IP2X This equipment is not suitable for use in the presence of a flammable anesthetic mixture with air, Oxygen, or Nitrous Oxide. Applied Parts: Handpiece, Handpiece Cable, Pads, Pads Cable, Transducer, Transducer Sleeve, Transducer with Sensor
Transport and Storage	Temperatures: 10°C to +50°C Humidity: 10 to 90% non-condensing Atmospheric Pressure: 80.1 kPa minimum
Operation	Temperatures: 10°C to 25°C Humidity: 30% to 75% Altitude: 2000 meters maximum
Environment	Operating room, EMC Industrial, Class A

18.2. **Guidance and Manufacturer’s Declaration –**

The ACESSA System is intended for use in the electromagnetic environment specified below. The customer or the end user of the system should assure that it is used in such an environment.

Guidance and manufacturer’s declaration – Electromagnetic Emissions		
Emissions test	Compliance	Electromagnetic environment - guidance
RF emissions CISPR 11	Group 1	The system uses RF energy only for its internal function. Therefore, its RF emissions are very low
RF emissions CISPR 11	Class A	The EMISSIONS characteristics of this equipment make it suitable for use in industrial areas and hospitals (CISPR 11 class A). If it is used in a residential environment (for which CISPR 11 class B is normally required) this equipment might not offer adequate protection to radio-frequency communication services. The user might need to
Harmonic emissions IEC 61000-3-2	Class A	
Voltage fluctuations/flicker emissions IEC 61000-3-3	Complies	

Guidance and manufacturer’s declaration – Electromagnetic Emissions		
Emissions test	Compliance	Electromagnetic environment - guidance
		take mitigation measures, such as relocating or re-orienting the equipment.

If the system is operated within the electromagnetic environment listed in the Guidance and manufacturer’s declaration – Electromagnetic Emissions table, the system will remain safe and provide the following essential performance:

- measure, monitor and control the RF energy output for ablation and coagulation
- monitor the temperature of the thermocouples in the needles of the handpiece
- monitor the temperature of the thermocouples in the pads that provide a return path for the RF energy

Guidance and manufacturer’s declaration – Electromagnetic Immunity			
Immunity test	IEC 60601 test level	Compliance level	Electromagnetic environment - guidance
Electrostatic discharge (ESD) IEC 61000-4-2	± 8 kV contact ± 15 kV air	± 8 kV contact ±2kV, ±4kV, ±8kV, and ±15 kV air	Floors should be wood, concrete or ceramic tile. If floors are covered with synthetic material, the relative humidity should be at least 30%.
Electrical fast transient/burst IEC 61000-4-4	± 2 kV for power supply lines ± 1 kV for input/output lines	± 2 kV for power supply lines ± 1 kV for input/output lines	Mains power quality should be that of a typical commercial or hospital environment.
Surge IEC 61000-4-5	± 0.5kV, ±1 kV for line to line ± 0.5kV, ±1 kV, ±2kV for line to ground	±0.5kV, ±1kV line-to-line ±0.5kV, ±1kV, ±2kV line to ground	Mains power quality should be that of a typical commercial or hospital environment.
Voltage dips, short interruptions and voltage variations on power supply input lines IEC 61000-4-11	100% drop, 0.5 periods, 0°, 45°, 90°, 135°, 180°, 225°, 270°, 315°  100% dip, 1 period  30% dip, 25/30 periods	100% drop, 0.5 periods, 0°, 45°, 90°, 135°, 180°, 225°, 270°, 315°  100% dip, 1 period  30% dip, 25/30 periods	Mains power quality should be that of a typical commercial or hospital environment. If the user of the device requires continued operation during power mains interruptions, it is recommended that the device be powered from an uninterruptible power supply or a battery.
Power frequency (60 Hz) magnetic field IEC 61000-4-8	30 A/m	30 A/m	Power frequency magnetic fields should be at levels characteristic of a typical location in a typical commercial or hospital environment.

Guidance and manufacturer’s declaration – Radiofrequency Electromagnetic Immunity			
Immunity test	IEC 60601 test level	Compliance level	Electromagnetic environment - guidance
Conducted RF IEC 61000-4-6	3 Vrms 150 kHz to 80 MHz 6 Vrms ISM bands 150kHz to 80MHz	3 Vrms  6 Vrms	Portable and mobile RF communications equipment should be used no closer to any part of the system, including cables, than the recommended separation distance calculated from the equation applicable to the frequency of the transmitter.  <b>Recommended separation distance:</b> $d = [1.2] \sqrt{P}$ $d = [1.2] \sqrt{P}$ 80 MHz to 800 MHz $d = [2.3] \sqrt{P}$ 800 MHz to 2.5 GHz
Radiated RF	3 V/m	3 V/m	Where $P$ is the maximum output power rating of the

Guidance and manufacturer's declaration – Radiofrequency Electromagnetic Immunity			
Immunity test	IEC 60601 test level	Compliance level	Electromagnetic environment - guidance
IEC 61000-4-3	80 MHz to 2.7 GHz		transmitter in watts (W) according to the transmitter manufacturer and <i>d</i> is the recommended separation distance in meters (m).
Radiated RF Proximity Fields	Per 60601-1-2 section 8.10 Table 9.	Per 60601-1-2 section 8.10 Table 9.	Field strength from fixed RF transmitters, as determined by an electromagnetic site survey, <sup>a</sup> should be less than the compliance level in each frequency range. <sup>b</sup>  Interference may occur in the vicinity of equipment marked with the following symbol:  
<p>Note 1. At 80 MHz and 800 MHz, the higher frequency range applies.</p> <p>Note 2. These guidelines may not apply in all situations. Electromagnetic propagation is affected by absorption and reflected from structures, objects and people.</p> <p><sup>a</sup> Field strengths from fixed transmitters, such as base stations for radio (cellular/cordless) telephones and land mobile radios, amateur radio, AM and FM radio broadcast cannot be predicted theoretically with accuracy. To assess the electromagnetic environment due to fixed RF transmitters, an electromagnetic site survey should be considered. If the measured field strength in the location in which the system is used exceeds the applicable RF compliance level above, the system should be observed to verify normal operation. If abnormal performance is observed, additional measures may be necessary, such as re-orienting or relocating the system.</p> <p><sup>b</sup> Over the frequency range 150 KHz to 80 MHz, field strengths should be less than <math>[V_1]</math> V/m.</p>			

Recommended separation distance between portable and mobile RF communications equipment and the system			
The system is intended for use in an electromagnetic environment in which radiated RF disturbances are controlled. The customer or its end user of the system can help prevent electromagnetic interference by maintaining a minimum distance between portable and mobile RF communications equipment (transmitters) and the system as recommended below, according to the maximum output power of the communications equipment.			
Related maximum output power of transmitter (W)	Separation distance according to frequency of transmitter (m)		
	150 kHz to 80 MHz $d = [3.5/V_1]VP$	80 MHz to 800 MHz $d = [3.5/E_1]VP$	800 MHz to 2.5 GHz $d = [7/E_1]VP$
0.01	.17	.17	.23
0.1	.37	.37	.74
1	1.17	1.17	2.33
10	3.69	3.69	7.38
100	11.67	11.67	23.33
For transmitter rated at a maximum output power not listed above, the recommended separation distance <i>d</i> in meters (m) can be estimated using the equation applicable to the frequency of the transmitter, where <i>P</i> is the maximum output power rating of the transmitter in watts (W) according to the transmitter manufacturer.			
<p>Note 1. At 80 MHz and 800 MHz, the higher frequency range applies.</p> <p>Note 2. These guidelines may not apply in all situations. Electromagnetic propagation is affected by absorption and reflected from structures, objects and people.</p>			

18.3. Technical Characteristics

Coagulation Mode Output at Various Settings into Various Loads

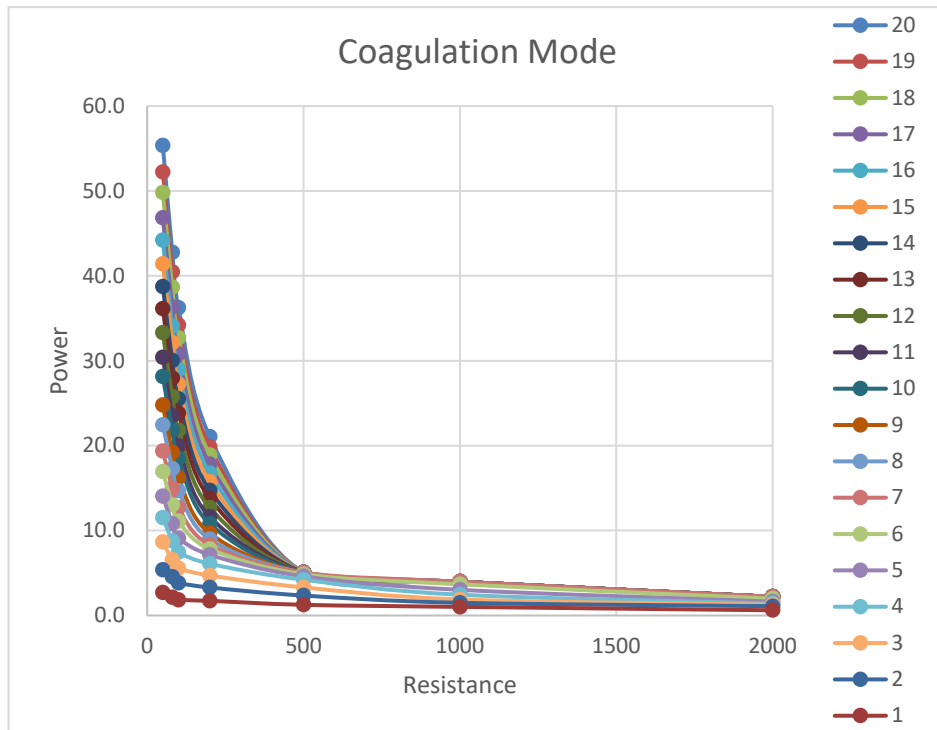

Approximate peak coag voltage vs. load resistance at all levels (“coag level” per the user interface).  
 Note: The load for coag will increase as the affected tissue cauterizes and dries. As the voltage level increases, the effect of coag is more immediate. However, slower coagulation (lower levels) may be more effective.

Watts of Power vs.  $R_{load}$  (Ablate Modes)

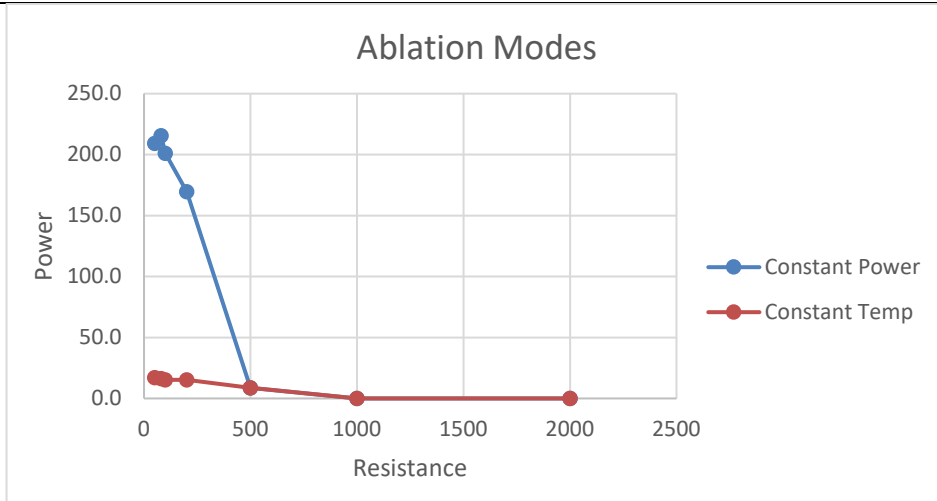

Note: The unit is limited at low load impedances by maximum available current and is limited at high load impedances by maximum available voltage. 200 watts is only available over a load range of 50 Ω to 80 Ω. The system will not ablate any loads over the system ablate high resistance alert of >511Ω.

#### 18.4. Compliance to Safety and Performance Standards

The Acessa ProVu System has been tested to the following standards:

Reference Number	Title
ISO 14971:2007	Medical devices – Application of risk management to medical devices (ISO 14971:2007, Corrected version 2007-10-01)
EU Directive 93/42/EEC	Medical Devices Directive (MDD)
ASTM D4169-16	Standard Practice for Performance Testing of Shipping Containers and Systems
IEC 60601-1 Ed. 3.1	Medical electrical equipment - Part 1: General requirements for basic safety and essential performance
IEC 60601-1-2 Ed. 4.0	Medical electrical equipment - Part 1-2: General requirements for basic safety and essential performance - Collateral standard: Electromagnetic compatibility - Requirements and tests
IEC 60601-2-2 Ed 5.0:2017	Medical electrical equipment - Part 2-2: Particular requirements for basic safety and essential performance of endoscopic equipment
IEC 62304 Ed. 1.1	Medical Device Software – Software Life Cycle Processes
IEC 60529 Ed 2.2:2015	Degrees of Protection Provided by Enclosures (IP Code)
ISO 13485: Ed 3:2016	Medical devices -- Quality management systems -- Requirements for regulatory purposes

### 19. Trouble Shooting

#### 19.1. Faults, Alerts, and Errors

- The system detects and displays fault and error conditions.
- A fault is a correctible condition that produces an Alert screen while an error is irreversible and requires system reboot to clear.
- When a fault occurs with RF on, RF is automatically turned off with audible and visual alerts provided. The user will be required to press the “Check” button to acknowledge the alert.
- When a fault occurs with RF off, it is indicated by a visual alert only.
- If the system components that provide Guidance fail, the display will revert to displaying the Ultrasound screen only.

#### 19.2. Fault/Alert Code Table



















Condition	Visual Alert	Audible Alert	Solution
Tip of Ultrasound Transducer is near the edge of the field.	“UT near edge of field”	No	Continue the procedure.
Tip of Handpiece shaft is near the edge of the field.	“Handpiece near edge of field”	No	Continue the procedure.
Handpiece is out of the tracking field.	“Handpiece out of field”	No	Move the handpiece into the field
Ultrasound transducer is out of the tracking field.	“UT out of field”	No	Move the transducer into the field
Metal has been detected in the tracking field.	“Remove metal or interference”	No	Remove metal from the field
The software is experiencing poor-quality tracking	“Bad Tracking”	No	Monitor the tracking
Handpiece sensor signal is lost	"Handpiece tracking signal lost"	No	1. Check Handpiece or cable connection 2. If connections are good, replace Cable. 3. If Cable was good, replace Handpiece.

Condition	Visual Alert	Audible Alert	Solution
Ultrasound Transducer (or sleeve) is unplugged	"Connect UT (or Sleeve)"	No	Connect UT (or Sleeve)
Ultrasound Transducer (or sleeve) sensor or cable is defective.	UT tracking signal lost"	No	1. Check transducer or sensor cable connection 2. Replace Transducer or continue without guidance.
The field generator signal is lost	"Field Generator not connected"	No	Check the Field Generator connections.
The user has plugged in a new tool and it takes a long time for the software to initialize it	"Please wait while the new tool is configured"	No	Wait
The system cannot read the Handpiece SROM ID or data	"Cannot read calibration data. Replace Handpiece"	No	Replace the Handpiece
The system cannot read the Sleeve SROM ID or data	"Cannot read calibration data"	No	1. Change Sleeve 2. Continue case without guidance
Handpiece disconnected	"Handpiece is unplugged"	Yes	1. Press Acknowledge (Check) Button. 2. Check Handpiece or cable connection. 3. If connections are good, replace Cable. 4. If Cable was good, replace Handpiece.
Either one or both Pads disconnected  NOTE: Two pads are required for ABLATION, but only 1 pad is required for COAGULATION.	"Pad is unplugged"	Yes	1. Press Acknowledge (Check) Button. 2. Check Pad or cable connection. 3. If connections are good, replace Cable. 4. If Cable was good, replace Pad.
Fewer than 4 valid (functioning) Handpiece TCs	"Handpiece: Not enough valid TCs"	Yes	1. Press Acknowledge (Check) Button. 2. Cool Handpiece tip. 3. If they are still invalid after cooling, replace handpiece.
Fewer than 3 valid TCs on each of 2 pads	"Pads: Not enough valid TCs"	Yes	1. Press Acknowledge (Check) Button. 2. Check Pad Cable connection to the Pad and Console. 3. If Pads are connected, replace the Pads.
Either or both pads have a temperature $\geq 44$ C	Text: "Pad temperature over limit"	Yes	1. Press Acknowledge (Check) Button. 2. Wait for temperatures to cool or cool the pad to $<40^{\circ}\text{C}$ to continue the procedure.
Ablate high resistance	"RF output ended, ablate high resistance, possible desiccation"	Yes	1. Retract the Electrodes and rotate the Handpiece slightly, then deploy the Electrodes again. 2. Check that the Handpiece is placed into the tissue correctly and the pads are completely adhered to the skin. 3. Check proper connections at both ends of the extension cables. 4. Check for char on the Handpiece tip. A sterile disposable wipe moistened with 70/30 isopropyl alcohol may be used to clean the trocar tip. Dry the Trocar or allow it to evaporate before use.
RF target time limit exceeded	"RF output ended, maximum target time exceeded"	Yes	12 minute time limit has been reached. Re-start RF if desired.









Condition	Visual Alert	Audible Alert	Solution
Pad contact resistance high during ablation	"RF output ended, high pad contact resistance"	Yes	A high pad contact resistance was detected. 1. Check the pads to ensure that they are in good contact with the patient. 2. Replace the pads (if necessary).
Unrecoverable error (e.g. failed SBC to RF communications)	"Instrument failure. Please power down the machine"	if possible	1. Press and hold the Standby pushbutton for about 5 seconds and then release it. 2. Then turn off the rear power switch. 3. Wait at least 10 seconds and then restart the Console. 4. If it happens again, call Acesa Health with failure number.
Instrument encounters a fatal error condition.	An error number and error text will be displayed	if possible	1. Press and hold the Standby pushbutton for about 5 seconds and then release it. 2. Then turn off the rear power switch. 3. Wait at least 10 seconds and then restart the Console. 4. If it happens again, call Acesa Health with failure number.
Guidance system failure The software has encountered an error, and the user is given a code to report to Tech Support	"Guidance Failure <varies>. Contact Technical Support"	Yes	Call Acesa Health with failure number.

## 20. Glossary of Symbols and Product Graphics





## 20.1. Symbols

Symbol	Standard Symbol Reference Number	Symbol Title /Description	Symbol	Standard Symbol Reference Number	Symbol Title/ Description
	EN 50419	<b>Recycle: Electronic Equipment / Do Not Throw Away.</b>		IEC 60417-5032:2002	<b>Alternating Current /</b> To indicate on the rating plate that the equipment is suitable for alternating current only; to identify relevant terminals.
Rx Only	US 21 CFR 801.109	<b>Prescription Only /</b> Device restricted to use by or on the order of a physician.		IEC 60417-5140:2003	<b>Radio Frequency /</b> To indicate generally elevated, potentially hazardous, levels of nonionizing radiation, or to indicate equipment or systems e.g. in the medical electrical area that include RF transmitters or that intentionally apply RF electromagnetic energy for diagnosis or treatment.
	IEC 60601-1:2012 Table D.1, Symbol 20	<b>BF Type Applied Part /</b> To identify a type BF applied part complying with IEC 60601-1.		IEC 60417-5021:2002	<b>Potential Equalization Terminal /</b> To identify the terminals which, when connected together, bring the various parts of an equipment or of a system to the same potential, not necessarily being the earth (ground) potential, e.g. for local bonding.
	IEC 60417-5331: 2002	<b>Not Anesthetic Proofed /</b> Not suitable for use with flammable anaesthetics!		IEC 60601-1:2012 Table D.2, Symbol 10	<b>Follow Instructions for Use /</b> Refer to instruction manual/booklet.
	IEC 60417 - 5036	<b>Warning: Electricity /</b> Warning dangerous voltage.		ISO 15223-1:2016 5.1.3	<b>Date of Manufacture /</b> Indicates the date when the medical device was manufactured.
	ISO 15223-1:2016 5.4.2	<b>Single Use only /</b> Indicates medical device that is intended for one use, or for use on a single patient during a single procedure.		IEC 60417-5016: 2002	<b>Fuse Rating /</b> To identify fuse boxes or their location.
	ISO 15223-1:2016 5.1.5	<b>Lot Identification /</b> Indicates the manufacturer's batch code so that the batch or lot can be identified.		ISO 15223-1:2016 5.1.6	<b>Catalogue or Model Number /</b> Indicates the manufacturer's catalogue number so that the medical device can be identified.
	ISO 15223-1: 2016 5.1.7	<b>Serial Number /</b> Indicates manufacturer's serial number so specific medical device can be identified.		IEC 60417-505: 2002	<b>Monitor /</b> To identify the terminals and controls for a television monitor.
	USB Implementors Forum, Inc.	<b>USB Port /</b> External interface to support data transfer to peripheral devices.		ISO 15223-1:2016 5.1.4	<b>Use by /</b> Indicates the date after which the medical device is not to be used (YYYY-MM-DD).
	ISO 15223-1, Clause 5.3.8	<b>Storage temperature range /</b> Indicates range of temperature the medical device can be safely exposed.		ISO 15223-1, Clause 5.3.7	<b>Storage humidity range /</b> Indicates range of humidity to which the medical device can be safely exposed.



Symbol	Standard Symbol Reference Number	Symbol Title /Description	Symbol	Standard Symbol Reference Number	Symbol Title/ Description
	ISO 15223-1:2016 5.2.3	<b>Sterilized Using Ethylene Oxide /</b> Indicates medical device has been sterilized using ethylene oxide.		ISO 15223-1:2016 5.1.1	<b>Manufacturer /</b> Indicates the medical device manufacturer.
	IEC 60417-5009	<b>Stand-by /</b> To identify the switch or switch position by means of which part of the equipment is switched on in order to bring it into the stand-by condition, and to identify the control to shift to or to indicate the state of low power consumption.		ISO 15223-1:2016 5.4.4	<b>Attention, see Instructions For Use /</b> Indicates the need for the user to consult the instructions for use for important cautionary information such as warnings and precautions.
	ISO 15223-1:2016 5.3.4	<b>Keep dry /</b> Indicates a medical device that needs to be protected from moisture.	IP2X	IEC 60529	<b>IP2X/</b> Protection against approach by fingers.
	ISO 60601-2-1:2009; IEC 1193/06, Figure 201.102: 2009	<b>HF Isolated Patient Circuit/</b> High Frequency Isolate Patient Circuit.		ISO 7000 No. 659	<b>Biohazard/</b> Dispose of biohazardous materials according to local safety regulations.
	ISO 15223-1:2016 5.2.7	<b>Non-sterile /</b> Sterilize Prior to Use (manufacturer does not provide this device sterile)			

20.2. Product Graphics Glossary

Product Icon	Icon Name	Description
	Dual Foot Pedal Port	Port to connect Dual Foot Pedal Cable to Acessa ProVu System Console
	Handpiece Port	Port to connect Acessa ProVu Handpiece cable to Acessa ProVu System Console
	Pad Cable Port	Port to connect Acessa Pad cable to Acessa ProVu System Console
	Transducer Sensor Port	Port to connect Acessa ProVu Transducer cable to Acessa ProVu System Console
	Field Generator Port	Port to connect either Acessa Table Top Field Generator or Acessa ProVu Planar Field Generator cable to Acessa ProVu System Console

Copyright 2018, Acessa Health Inc.  
 U.S Patent 6,840,935 2005 Acessa Procedure.  
 Acessa is a trademark of Acessa Health Inc.

## 21. Warranty Statement

Every Model 7100 Acessa ProVu System sold by Acessa Health Inc. carries a 1-year manufacturer's warranty from the date of sale. Acessa Health Inc. hereby guarantees that the product is free from any defect in material and workmanship. Acessa Health's obligation under this warranty is expressly limited to repairing or replacing any unit that fails, the repair or replacing is at the sole discretion of Acessa Health. This warranty excludes damage or failure due to abuse, usage beyond intended use, and/or improper installation. Acessa Health Inc. reserves the right to perform warranty service in its factory or at the customer's site based on the nature of the repair and/or the type of service. Acessa Health does not allow service training for any non-authorized service group. Acessa Health Inc. must complete all service; any tampering or unauthorized servicing may void any manufacturer's warranties.

### LIMITATIONS and OBLIGATIONS

THE FOREGOING WARRANTIES ARE EXCLUSIVE AND IN LIEU OF ALL OTHER EXPRESS WARRANTIES AND IMPLIED WARRANTIES, INCLUDING BUT NOT LIMITED TO, THE IMPLIED WARRANTIES OF MERCHANTABILITY AND FITNESS FOR A PARTICULAR PURPOSE. ACCESSA HEALTH'S OBLIGATION UNDER THESE WARRANTIES SHALL NOT INCLUDE ANY LIABILITY FOR LOSS OF PROFITS, BUSINESS INTERRUPTION DAMAGES, DIRECT, INDIRECT OR CONSEQUENTIAL DAMAGES OR DELAYS. ACCESSA HEALTH INC. SHALL NOT BE LIABLE FOR INCIDENTAL OR CONSEQUENTIAL DAMAGES RESULTING FROM BREACH OF THIS WRITTEN WARRANTY OR ANY IMPLIED WARRANTY.

ANY IMPLIED WARRANTY OF MERCHANTABILITY OR FITNESS FOR A PARTICULAR PURPOSE APPLICABLE TO THIS PRODUCT IS LIMITED TO THE DURATION OF THIS WRITTEN WARRANTY.

Some states do not allow limitations on how long an implied warranty lasts as well as the exclusion or limitation of incidental or consequential damages, so the above exclusion or limitation may not apply. The warranty gives you specific legal rights, and you may also have other rights which vary from state to state.

Appendix 1: Acoustic Output Reporting Table for Track 3

Transducer Model:  
Operating Mode:

Acessa ProVu  
B-Mode



**Acessa ProVu Transducer with Sensor  
(Model Number 7700)**  
Instructions for Use

Index Label	MI	TIS			TIB	TIC	
		Scan	Non-scan		Nonscan		
			A <sub>prT</sub> ≤1 cm <sup>2</sup>	A <sub>prT</sub> >1 cm <sup>2</sup>			
Maximum index value	0.786	0.068	-	-	-	(a)	
Associated acoustic parameter	pr.3 (MPa)	1.797					
	W <sub>0</sub> (mW)		10.06	-	-	(a)	
	min of [W <sub>-3</sub> (z <sub>1</sub> ), I <sub>TA,3</sub> (z <sub>1</sub> )] (mW)				-		
	z1 (cm)				-		
	zbp (cm)				-		
	zsp (cm)	1.60				-	
	deq(zsp) (cm)					-	
	fc (MHz)	5.23	5.23	-	-	-	(a)
	Dim of A <sub>sprt</sub>	X (cm)		0.78	-	-	(a)
Y (cm)			0.40	-	-	(a)	
Other Information	PD (μsec)	0.227					
	PRF (Hz)	7936					
	p <sub>r</sub> @ PII <sub>max</sub> (MPa)	2.40					
	d <sub>eq</sub> @ PII <sub>max</sub> (cm)					-	
	Focal Length	FL <sub>x</sub> (cm)		1.8	-	-	
		FL <sub>y</sub> (cm)		2.2	-	-	
IPA.3 @ MI <sub>max</sub> (W/cm <sup>2</sup> )	246.6						
Operating Control Conditions	19 mm focus, 5 MHz	✓	✓				



**CAUTION:** Federal Law (U.S) restricts this device to sale by or on the order of a physician trained in the use of the Acessa ProVu System for ablation of symptomatic uterine fibroids

**Note 1:** Information need not be provided for any formulation of TIS not yielding the maximum value of TIS for that mode.

**Note 2:** Information need not be provided regarding TIC for any TRANSDUCER ASSEMBLY not intended for transcranial or neonatal cephalic uses.

**Note 3:** Information on MI and TI need not be provided if the equipment meets both the exemption clauses given in 51.2 aa) and 51.2 dd).

(a) Intended use does not include cephalic so TIC is not computed

**MANUFACTURER:** Acessa Health Inc.  
317 Grace Ln, Suite 200  
Austin, TX 78746 USA  
Telephone: 877.412.3828  
Fax: 925.605.0327

www.acesaprocedure.com  
Acessa is a trademark of Acessa Health Inc.  
Copyright 2018, Acessa Health Inc.

This brochure provides basic information on the Acesa ProVu Transducer with Sensor. For complete information on how to use this device with the Acesa ProVu System see the Acesa ProVu System User’s Guide (PL-01-0040).

**Product description:**

The Acesa ProVu Transducer with Sensor is an ultrasound transducer designed specifically for use with the Acesa ProVu System to display the image in B-Mode only. The operator has access to operating controls for frequency, focus, depth, and gain.

**Acesa ProVu System Indications for use:**

The Acesa ProVu Transducer with Sensor is an accessory to the Acesa ProVu System (Model 7100) for use during the Acesa procedure.

**Warnings:**

- This Transducer may injure the human body. Do not use it in continuous contact with the human body for more than 60 minutes. This Transducer is designed for temporary use during surgery.
- This Transducer must not be used in direct contact with the heart. Use the probe only for the purposes described above.

**Precautions:**

- Prior to use, refer to the Acesa ProVu System User’s Guide (PL-01-0040) for complete information.
- The Acesa ProVu Transducer with Sensor is designed for use with the Acesa ProVu System.
- The Acesa ProVu Transducer with Sensor should be used only by physicians and medical staff who have been trained and have a thorough understanding of the system.
- The Acesa ProVu Transducer with Sensor is a precision instrument that is fragile and vulnerable to damage by shock.
- Care must be taken when handling the Acesa ProVu Transducer with Sensor not to drop it or strike it against hard surfaces. When dropped or struck against a hard surface, the Transducer may develop an abnormal state that cannot be located visually. If this occurs, contact Acesa Health for replacement.
- Always use the Transducer in a dried state. Condensation or waterdrops may appear by being moved from cold to warm place. Use without proper care, can cause short-circuiting.
- The Acesa ProVu Transducer has not been validated for more than 100 uses.
- Perform the ultrasound procedure prudently using the principle of ALARA (As Low As Reasonably Achievable)

**Potential Complications:**

Potential complications of RF ablations may include, but are not limited to:

- Unintended Burns
- Bleeding
- Pain
- Local and/or Systemic Infections
- Hematoma at entry side
- Tissue Nerve Damage

**Limitations of Reprocessing**

The Acesa ProVu Transducer with Sensor has been designed and tested to perform effectively for a minimum of 100 cycles of cleaning and sterilization. Therefore, replacement is recommended to ensure safe and effective performance. See the inspection section for additional guidance on evaluating device functionality.

Note: Use life is dependent upon many factors, including the number or reprocessing cycles, compliance with device instructions, as well as precautions taken in handling cleaning, and storage. Proper care must be taken of the transducer to ensure the transducer remains in good working order.

**Principles of Operation**

This Transducer and the diagnostic equipment enable B-mode imaging using ultrasonic waves. These instruments operate under the principles described below.

- (1) When an electric pulse signal is applied from the main equipment to the probe, the transducer in the probe makes vibrations while converting electric vibration to mechanical vibration energy. This enables ultrasonic waves to be emitted into media such as an organism or liquid that is in contact with the irradiation area of the transducer.
- (2) The Transducer is also used to receive ultrasonic reflected waves. The Transducer mechanically vibrates as a result of the vibration of the received ultrasonic waves and receives a signal through an electro-mechanical conversion operation that converts that mechanical vibration into electric energy.
- (3) Since multiple transducers are arranged in the probe, the electric scan operation of the ultrasonic pulse signal can be repeated many times, and the reflected signal received can be observed in real time.
- (4) The time required between transmission and reception is converted into a distance, and images are displayed on the screen.

**Device Description**



Indications for Use	Laparoscopic surgery
Type of array	Linear
Number of elements	128
Center frequency	7.5MHz
Bandwidth	≥75%
Focus adjustment	.2-8
Environmental conditions	Ambient temperature 10°C~40°C 50°F~104°F Relative humidity 30%~85% Atmospheric pressure 700 hPa~1060 hPa
Diameter	Diameter 10 mm
Cable length	2.5m

**Track 3 Summary**

Transducer	ISPTA.3	TI Type	TI Value	MI	IPA.3@M Imax
Acesa ProVu	17.0 mW/cm <sup>2</sup>	TIS	0.068	0.79	246.6 W/cm <sup>2</sup>

See Appendix 1 for Acoustic Output Reporting Table for Track 3.

**Storage Conditions**

Ambient temperature: 10°C~50°C  
14°F~122°F  
Relative humidity: 10%~90%  
Atmospheric pressure 700 hPa~1060 hPa

**Device Inspection**

Conduct the following Inspections before each use and before cleaning and sterilization. Verify the following:

1. Insertion area of Transducer is free from holes, dents, scratches, cracks, deformations and color changes on the surface.
2. There are no flaws, fissure, delamination or any other nonconformities on the connector and cable.
3. There are no loose or missing components

Do not use the device if it does not pass inspection. Contact Acesa Health for service or a replacement device.

**Device Preparation and Operation**

1. Store in a dry place.
2. Clean and sterilize the Acesa ProVu Transducer with Sensor. Refer to the recommended cleaning and sterilization instruction.
3. Place the Acesa ProVu Transducer with Sensor in the sterile field.
4. Conduct a Visual Safety Check. Refer to section 'Device Inspection'.
5. Attach the Acesa ProVu Transducer with Sensor to the Acesa ProVu Console.
6. Ensure that the Ultrasound function displays on the Acesa ProVu Console.

**Note:** For detailed instructions and illustrations on connectors and configuration see the Acesa ProVu System User's Guide (PL-01-0040).

**Recommended Cleaning and Sterilization**

Clean and sterilize the transducer before first and every use. Acesa Health recommends the following cleaning and sterilization steps as outlined below. Prior to cleaning and sterilization conduct an inspection according to the 'Device Inspection' section of this document. All Transducers must be thoroughly cleaned, rinsed and dried according to the process described in this section before proceeding with sterilization of the device. Thorough cleaning and rinsing are the first and most important steps in reprocessing of any reusable medical device. Without thorough cleaning and rinsing, it is not possible to achieve effective sterilization of the device.

**Cleaning**

Rinse contact or insertion area of probe thoroughly with running water for two (2) minutes at 40°C (104°F), making sure all foreign matter, blood, mucus, etc. are removed with a debris removal tool (ex. soft bristle brush, lint free cloth, sponge, etc.).

Immerse device (shaft and cables only) in an Enzymatic Cleaner with water at approximately 43°C (110°F) for three (3) minutes, while wiping and scrubbing shaft and cables with a debris removal tool.

*Follow the detergent manufacturer's instructions for concentration and other conditions.*

Rinse with water for four (4) minutes at 40°C (104°F).

Dry with a lint free cloth.

Thoroughly examine all surfaces that have been cleaned and visually inspect the entire device to make sure it is clean.

**Table 1.** Recommended Manual Cleaning Durations

TREATMENT	TIME(MM:SS)	CLEANING SOLUTION
Rinse under running water with a debris removal tool ensuring all soil has been removed.	02:00	Water 40°C (104°F)
Immerse device while wiping and scrubbing Shaft and Wires with a debris removal tool.	03:00	Enzymatic Cleaner 43°C (110°F)
Rinse	04:00	Water 40°C (104°F)

**Sterilization**

The Acesa ProVu Transducer with Sensor is provided non-sterile. The transducer is sterilized using low-temperature hydrogen peroxide gas plasma technology, selected for its ability to process heat- and moisture-sensitive medical devices quickly, without producing toxic residues or emissions. The Acesa transducer has been designed to be compatible with ASP STERRAD® 100NX, NX, and 100S systems, as well as STERIS V-PRO® systems.

*NOTE: Only one (1) Acesa ProVu Transducer with Sensor should be run in a STERRAD® NX, 100S, or V-PRO® load at a time and No more than two (2) Acesa ProVu Transducers with Sensor should be run in a STERRAD® 100NX load at a time. All sterilization should be performed with the black connector cap off.*

The following low-temperature hydrogen peroxide gas plasma sterilization cycles have been validated to result in a SAL of 10<sup>-6</sup> in accordance with applicable standards, including AAMI TIR12:

**Table 2.** Recommended Sterilization Cycles (STERRAD®)

STERILIZATION METHOD	PREPARATION*	STERRAD® STERILIZATION SYSTEM & CYCLE TYPE
Low-temperature Hydrogen Peroxide Gas Plasma Technology	Double wrap utilizing (inner wrap 500 grade, outer wrap 600 grade) FDA cleared Sterilization Wrap	STERRAD® Model 100NX Standard Cycle.
	Place into APTIMAX® Instrument Tray, PC:13837	STERRAD® Model NX Standard Cycle.
	Double wrap with H400 Sterilization Wrap, Halyard Health, PC:68248	STERRAD® Model 100S Short and Long Cycles.

*\*Device preparation is based on the Acesa validated process. Reference appropriate STERRAD® model instructions for additional information or guidance.*

**Table 3.** Recommended Sterilization Cycles (V-PRO®)

STERILIZATION METHOD	PREPARATION*	STERIS V-PRO® STERILIZER & CYCLE TYPE
Low-temperature Hydrogen Peroxide Gas Plasma Technology	Place into STERIS Sterilization Tray and wrap with H600 OneStep wrap	V-PRO® 1 – Standard Cycle.
		V-PRO® 1 Plus – Lumen and Non-Lumen Cycles
		V-PRO® maX – Lumen, Non-Lumen & Flexible Cycles
		V-PRO® maX 2 – Lumen, Non-Lumen, Flexible and Fast Non-Lumen Cycles
		V-PRO® 60 – Lumen, Non-Lumen and Flexible Cycles
		V-PRO® s2 – Lumen, Non-Lumen, Flexible and Fast Cycles

*\*Device preparation is based on the Acesa validated process. Reference appropriate V-PRO® model instructions for additional information or guidance.*

No toxic residues are left after STERRAD® or V-PRO® sterilization. No aeration is needed for devices sterilized using the STERRAD® or V-PRO® Systems.

Specific sterilization questions should be made directly either to Advanced Sterilization Products at: <http://www.aspii.com/>, Or STERIS Corporation at: <http://www.steris.com/>.

**WARRANTY:** Every Model Number 7700 Acesa ProVu Transducer with Sensor sold by Acesa Health Inc. carries a 1-year manufacturer's warranty from the date of sale. Acesa Health Inc. hereby guarantees that the product is free from any defect in material and workmanship. Acesa Health's obligation under this warranty is expressly limited to repairing or replacing any unit that fails, the repair or replacing is at the sole discretion of Acesa Health. This warranty excludes damage or failure due to abuse, usage beyond intended use, and/or improper installation. Acesa Health Inc. reserves the right to perform warranty service in its factory or at the customer's site based on the nature of the repair and/or the type of service. Acesa Health does not allow service training for any non-authorized service group. Acesa Health Inc. must complete all service; any tampering or unauthorized servicing may void any manufacturer's warranties.











**LIMITATIONS and OBLIGATIONS**





THE FOREGOING WARRANTIES ARE EXCLUSIVE AND IN LIEU OF ALL OTHER EXPRESS WARRANTIES AND IMPLIED WARRANTIES, INCLUDING BUT NOT LIMITED TO, THE IMPLIED WARRANTIES OF MERCHANTABILITY AND FITNESS FOR A PARTICULAR PURPOSE. ACESHA HEALTH'S OBLIGATION UNDER THESE WARRANTIES SHALL NOT INCLUDE ANY LIABILITY FOR LOSS OF PROFITS, BUSINESS INTERRUPTION DAMAGES, DIRECT, INDIRECT OR CONSEQUENTIAL DAMAGES OR DELAYS. ACESHA HEALTH INC. SHALL NOT BE LIABLE FOR INCIDENTAL OR CONSEQUENTIAL DAMAGES RESULTING FROM BREACH OF THIS WRITTEN WARRANTY OR ANY IMPLIED WARRANTY.

ANY IMPLIED WARRANTY OF MERCHANTABILITY OR FITNESS FOR A PARTICULAR PURPOSE APPLICABLE TO THIS PRODUCT IS LIMITED TO THE DURATION OF THIS WRITTEN WARRANTY.

Some states do not allow limitations on how long an implied warranty lasts as well as the exclusion or limitation of incidental or consequential damages, so the above exclusion or limitation may not apply. The warranty gives you specific legal rights, and you may also have other rights which vary from state to state.

**Glossary of Symbols**

Symbol	Standard Reference	Symbol Title/Description
	US 21 CFR 801.109	<b>Prescription Only</b> / Device restricted to use by or on the order of a physician.
	ISO 15223-1:2016 5.1.5	<b>Lot Identification</b> / Indicates the manufacturer's batch code so that the batch or lot can be identified.
	ISO 15223-1:2016 5.1.1	<b>Manufacturer</b> / Indicates the medical device manufacturer.
	ISO 15223-1:2016 5.1.6	<b>Catalogue or Model Number</b> / Indicates the manufacturer's catalogue number so that the medical device can be identified.
	IEC 60601-1:2012 Table D.2, Symbol 10	<b>Follow Instructions for Use</b> / Refer to instruction manual/booklet.
	ISO 15223-1:2016 5.3.4	<b>Keep dry</b> / Indicates a medical device that needs to be protected from moisture.
	ISO 15223-1:2016 5.2.7	<b>Non-sterile</b> / Sterilize Prior to Use (manufacturer does not provide this device sterile)
	ISO 15223-1:2016 5.4.4	<b>Attention, see Instructions For Use</b> / Indicates the need for the user to consult the instructions for use for important cautionary information such as warnings and precautions.
	IEC 60601-1:2012 Table D.1, Symbol 20	<b>BF Type Applied Part</b> / To identify a type BF applied part complying with IEC 60601-1
	ISO 7000 No. 659	<b>Biohazard</b> / Dispose of biohazardous materials according to local safety regulations
<b>IPX7</b>	IEC 60529	<b>IPX7</b> / Protection against immersion up to 1 meter

	ISO 15223-1:2016 5.1.6	<b>Catalogue or Model Number/</b> Indicates the manufacturer's catalogue number so that the medical device can be identified.
	IEC 60601-1:2012 Table D.2, Symbol 10	<b>Follow Instructions for Use /</b> Refer to instruction manual/booklet.
	ISO 15223-1:2016 5.4.2	<b>Single Use only /</b> Indicates medical device that is intended for one use, or for use on a single patient during a single procedure.
	ISO 15223-1:2016 5.4.4	<b>Attention, see Instructions For Use /</b> Indicates the need for the user to consult the instructions for use for important cautionary information such as warnings and precautions.



## Acessa ProVu Handpiece (7300) Instructions for Use



**CAUTION:** Federal Law (U.S.) restricts this device to sale by or on the order of a physician trained in the use of the Acessa ProVu System for ablation of symptomatic uterine fibroids



**MANUFACTURED FOR: Acessa Health Inc.**

317 Grace Ln, Suite 200  
Austin, TX 78746 USA

www.acessaprocedure.com  
Telephone: 877.412.3828  
Fax: 925.605.0327

Acessa is a trademark of Acessa Health Inc.  
Copyright 2018, Acessa Health Inc.  
U.S. and Foreign Patents Pending

**Product description:**

The Acesa ProVu Handpiece is an RF ablation device to be connected to the Acesa ProVu System. The Acesa ProVu Handpiece is designed to function with or without tracking. The Acesa ProVu Handpiece is equipped with a slider knob to control the deployment and retraction of the needle array.

The Acesa ProVu Handpiece (7300) is part of the Acesa ProVu System.

**Indications for use:**

The Acesa ProVu Handpiece is an accessory to the Acesa ProVu System (Model 7100) for use during the Acesa procedure. See the Acesa ProVu System User’s Guide (PL-01-0040) for additional information.

**Contraindication:**

- The tracking feature may not be used to guide the tip of the Acesa ProVu Handpiece once the tip has penetrated the uterine serosa. Ultrasound visualization must be used for fibroid penetration and treatment
- The Acesa ProVu Handpiece is not intended for any type of diagnostic use.
- Patients who are not candidates for laparoscopic surgery (e.g. patients with known or suspected intra-abdominal adhesions that would interfere with safe use of the Acesa ProVu Handpiece).
- Uterus adherent to pelvic tissue or viscera.
- Non-uterine pelvic mass.

**Warnings:**

- The safety and effectiveness of the tracking feature to guide the tip of the Acesa ProVu Handpiece has not been evaluated in clinical trials. Therefore, tracking should only be used until the device has penetrated the uterine serosa.
- Prior to use, refer to the Acesa ProVu User’s Guide (PL-01-0040) for complete information.
- For single patient use only! Re-use of the electrosurgical Acesa ProVu Handpiece may result in its failure as well as post-operative infection.
- Caution, Sharp Distal tip.
- The Acesa ProVu Handpiece should be used only by physicians and medical staff who have been trained and have a thorough understanding of the system.
- The Acesa ProVu Handpiece’s guidance capability has an accuracy of ±10 mm.
- The Acesa ProVu Handpiece is shipped sterile. DO NOT ATTEMPT TO RE-STERILIZE as doing so will result in product damage and may cause injury to patient or physician.
- When using the device in situations where vision may be limited, burns may result if the device is activated outside the field of view.
- Do not touch the Acesa ProVu Handpiece tip of the coagulating electrode and Dispersive Electrode at the same time especially when operating the system, as capacitive coupling may lead to burns.
- Do not use product after its expiration date (see packaging label)
- Always verify that the needles are fully retracted before positioning, advancing, or withdrawing the Acesa ProVu Handpiece.
- To avoid damage to the needles, maintain stability of the uterus position and do not rotate the Acesa ProVu Handpiece handle/shaft when needles are deployed in tissue.
- Excessive bending or kinking of Acesa ProVu Handpiece shaft may damage internal mechanicals rendering the device inoperable.
- When deploying the Acesa ProVu Handpiece needles, observe the force applied to the slider knob. Stop deployment if excessive resistance is felt. In all cases deployment should be accomplished with one hand while grasping the Acesa ProVu Handpiece. Higher resistance may indicate dense tissue; see Acesa ProVu User Guide for suggestions in treatment.
- During Coag mode, the user may experience char on the tip. A sterile disposable wipe moistened with 70/30 isopropyl alcohol may be used to clean the trocar tip. Dry the Trocar or allow it to evaporate before use. Before Acesa ProVu Handpiece insertion into peritoneal cavity, deploy needle array and inspect.
- After use, this product is potentially a biohazard. Handle and dispose of, in accordance with accepted medical practice and with applicable laws and regulations.

**Precautions:**

- Prior to use, refer to the Acesa ProVu User’s Guide (PL-01-0040) for complete information.
- The Acesa ProVu Handpiece is used with products manufactured by Acesa Health Inc. under the Acesa family of devices.
- The Acesa ProVu Handpiece cannot be used with any other radiofrequency generator. It can only be used with the Acesa ProVu System.
- The safety of electrosurgery will be greatly enhanced by a thorough knowledge of the medical literature on the subject. Study of specific information on the hazards and complications of the procedure in question is especially recommended. All packaging should be inspected prior to use.
- Do not use if the sterile barrier has been breached.

- Do not use if the packaging or product is damaged in any way.
- Do not use if product has been dropped.
- Once the Acesa ProVu Handpiece tip is visible in the ultrasound, within the area where the fibroid is located, the physician reverts to standard laparoscopic ultrasound imaging to place the tip within the fibroid. Tracking is no longer necessary at this point.

**Potential Complications:**

Potential complications of RF ablations may include, but are not limited to:

- Unintended Burns
- Bleeding
- Pain
- Local and/or Systemic Infections
- Hematoma at entry side
- Tissue Nerve Damage

**Device Preparation and Operation:**

1. Store in a dry place.
2. Remove package and place Acesa ProVu Handpiece in sterile field.
3. Attach the Acesa ProVu Handpiece to the Acesa ProVu Handpiece Cable.
4. Ensure that there are 6 thermocouple temperatures registering on the User Interface screen.
5. Deploy the needles once in the air and then retract before inserting the Acesa ProVu Handpiece into the site.
6. Placement and deployment of the Acesa ProVu Handpiece shaft must be done with ultrasound guidance.
7. Needle deployment and retraction is done with the slider knob as shown in the image below.

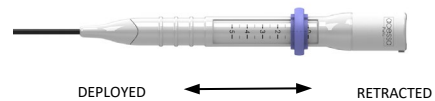

8. Retraction of the needles must be done before Acesa ProVu Handpiece removal or Coag is used.

**Warranty:** Acesa warrants the original purchase of the Acesa ProVu Handpiece shall be free of defects in material and workmanship when used as intended under normal surgical conditions and in conformance with its instructions for use. The obligation of Acesa under this warranty shall be limited to a replacement, at no charge, if examination shall disclose to the satisfaction of Acesa that the Acesa ProVu Handpiece does not meet this warranty.

**Glossary of Symbols**

Symbol	Standard Reference	Symbol Title/Description
Rx Only	US 21 CFR 801.109	<b>Prescription Only</b> / Device restricted to use by or on the order of a physician.
LOT	ISO 15223-1:2016 5.1.5	<b>Lot Identification</b> / Indicates the manufacturer's batch code so that the batch or lot can be identified.
	ISO 15223-1:2016 5.1.1	<b>Manufacturer</b> / Indicates the medical device manufacturer.
STERILE EO	ISO 15223-1:2016 5.2.3	<b>Sterilized Using Ethylene Oxide</b> / Indicates medical device has been sterilized using ethylene oxide.
	ISO 15223-1:2016 5.1.4	<b>Use by</b> / Indicates date after which medical device is not to be used (YYYY-MM-DD).





## Acessa Pad (Model Number 3000) Instructions for Use

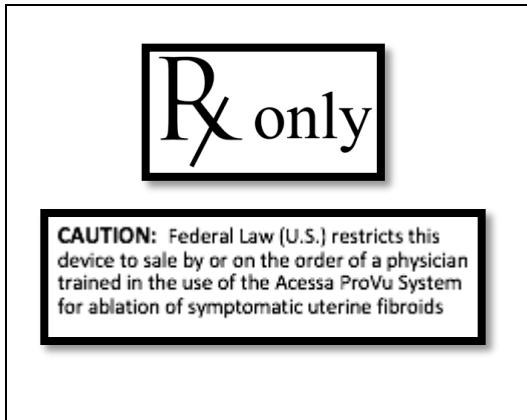

**Product Description:**

A set of two (2) disposable Pads that provide a return path for applied RF energy.

**Indications for Use:**

The Acessa Pad is an accessory to the Acessa Generator (Model 1000) or Acessa ProVu System (Model 7100) for use during the Acessa procedure. Intended for use with Pad cable (Model 4300) as return path for applied RF energy.

**Contraindication:**

The Acessa Pad is contraindicated for use any time use of the Acessa Generator or Acessa ProVu System is contraindicated.

**Instructions:**

1. The Pads should be used only by physicians and medical staff who have been trained and have a thorough understanding of the Ablation system.

2. Prep patient where pads will be placed. Prep per user facilities SOP and/or AORN or AAMI Standards in the placement of the pads.
3. Ensure intended site is clean and dry.
4. Remove the pads from their packaging.
5. Carefully peel back release liner from the pads and discard release liner.
6. Inspect cables and pads for damage. Do not use if they appear to be damaged.
7. Place pads exactly on the patient according to the illustration below.

Pad leading edge to be 25-50cm from ablation site

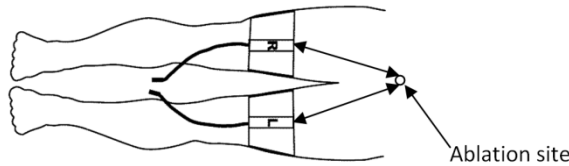

8. Avoid placement over scars, bony prominences, metal prostheses, or EEG electrodes.
9. Avoid placement where fluids may pool.
10. It is also recommended to avoid skin-to-skin or pad-to-pad contact, such as between the legs or between the torso and arms, by insulating with sheets or other dry material.
11. Verify entire pad surface conforms to patient applied surface (no bubbles or lifted surface).
12. Connect the pad cable on the patient's right leg to the "R" on the pad cable per the illustration below.
13. Connect the pad cable on the patient's left leg to the "L" on the pad cable per the illustration below.



14. If using with Acessa Generator (Model 1000), now attach the pad cable (Model 4300) to the port on the generator labeled with the product graphic below.



15. If using Acessa ProVu System (Model 7100), now attach the Pad Cable (Model 4300) to the port on the Acessa ProVu Console labeled with the product graphic below.



16. The Pads may be externally cooled at the discretion of the physician.







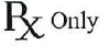

**Warnings:**

- Unintended skin burns may occur if Acessa Pads are not placed as instructed!
- DO NOT cut or modify the electrode in any manner. This will adversely affect the performance of the device and could cause unintended burns.
- For single patient use! Re-use of Pads may result in patient burn and/or infection.

**Precautions:**

- Store in a dry place.
- For monopolar use only!
- The Pads are shipped non-sterile.
- DO NOT use product after its expiration date (see packaging label).
- All packaging should be inspected prior to use.
- DO NOT use if the packaging or product is damaged in any way (including Hydrogel delamination or exposed metal contact).
- After use, this product is potentially a biohazard. Handle and dispose of, in accordance with accepted medical practice and with applicable laws and regulations.

Glossary of Symbols

Symbol	Standard Reference	Symbol Title/Description
	US 21 CFR 801.109	<b>Prescription Only</b> / Device restricted to use by or on the order of a physician.
	ISO 15223-1:2016 5.1.5	<b>Lot Identification</b> / Indicates manufacturer's batch code so the batch or lot can be identified.
	ISO 15223-1:2016 5.1.1	<b>Manufacturer</b> / Indicates the medical device manufacturer.
	ISO 15223-1:2016 5.4.2	<b>Single Use only</b> / Indicates medical device that is intended for one use, or for use on a single patient during a single procedure.
	ISO 15223-1:2016 5.1.4	<b>Use by</b> / Indicates date after which medical device is not to be used (YYYY-MM-DD).
	ISO 15223-1:2016 5.1.6	<b>Catalogue or Model Number</b> / Indicates manufacturer's catalogue number so medical device can be identified.
	IEC 60601-1:2012 Table D.2, Symbol 10	<b>Follow Instructions for Use</b> / Refer to instruction manual/booklet.
	ISO 15223-1:2016 5.4.4	<b>Attention, see Instructions For Use</b> / Indicates the need for the user to consult the instructions for use for important cautionary information such as warnings and precautions.
	ISO 15223-1:2016 5.2.7	<b>Non-sterile</b> / Sterilize Prior to Use (manufacturer does not provide this device sterile)



**MANUFACTURED FOR:** Acessa Health Inc.  
317 Grace Ln, Suite 200  
Austin TX 78746 USA

www.acessaprocedure.com  
Telephone: 877.412.3828  
Fax: 925.605.0327

Acessa is a trademark of Acessa Health Inc.  
Copyright 2018, Acessa Health Inc.  
U.S. and Foreign Patents Pending

**Table 3.** Recommended Sterilization Cycles (V-PRO®)

STERILIZATION METHOD	PREPARATION*	STERIS V-PRO® STERILIZER & CYCLE TYPE
Low-temperature Hydrogen Peroxide Gas Plasma Technology	Place into STERIS Sterilization Tray and wrap with H600 OneStep wrap	V-PRO® 1 – Standard Cycle.
		V-PRO® 1 Plus – Lumen and Non-Lumen Cycles
		V-PRO® maX – Lumen, Non-Lumen & Flexible Cycles
		V-PRO® maX 2 – Lumen, Non-Lumen, Flexible and Fast Non-Lumen Cycles
		V-PRO® 60 – Lumen, Non-Lumen and Flexible Cycles
		V-PRO® s2 – Lumen, Non-Lumen, Flexible and Fast Cycles

\*Device preparation is based on the Acesa validated process. Reference appropriate V-PRO® model instructions for additional information or guidance.

No toxic residues are left after STERRAD® or V-PRO® sterilization. No aeration is needed for devices sterilized using the STERRAD® or V-PRO® Systems.

Specific sterilization questions should be made directly either to Advanced Sterilization Products at: <http://www.aspii.com/>,  
Or STERIS Corporation at: <http://www.steris.com/>.



**Acesa ProVu Handpiece Cable  
(Model Number 7400)  
Instructions for Use**



**CAUTION:** Federal Law (U.S) restricts this device to sale by or on the order of a physician trained in the use of the Acesa ProVu System for ablation of symptomatic uterine fibroids

**Glossary of Symbols**

SYMBOL	STANDARD REFERENCE	SYMBOL TITLE/DESCRIPTION
	US 21 CFR 801.109	<b>Prescription Only</b> / Device restricted to use by or on the order of a physician.
	ISO 15223-1:2016 5.1.5	<b>Lot Identification</b> / Indicates the manufacturer's batch code so that the batch or lot can be identified.
	ISO 15223-1:2016 5.1.1	<b>Manufacturer</b> / Indicates the medical device manufacturer.
	ISO 15223-1:2016 5.1.6	<b>Catalogue or Model Number</b> / Indicates the manufacturer's catalogue number so that the medical device can be identified.
	IEC 60601-1:2012 Table D.2, Symbol 10	<b>Follow Instructions for Use</b> / Refer to instruction manual/booklet.
	ISO 15223-1:2016 5.2.7	<b>Non-sterile</b> / Sterilize Prior to Use (manufacturer does not provide this device sterile)



**MANUFACTURER:** Acesa Health Inc.  
317 Grace Ln, Suite 200  
Austin TX 78746 USA

www.acesaprocedure.com  
Telephone: 877.412.3828  
Fax: 925.605.0327

Acesa is a trademark of Acesa Health Inc.  
Copyright 2018, Acesa Health Inc.  
U.S. and Foreign Patents Pending

**Product Description:**

The Acesa ProVu Handpiece Cable provides connectivity of the Acesa ProVu Handpiece to the Acesa ProVu System.

**Indications for use:**

The Acesa ProVu Handpiece Cable is an accessory to the Acesa ProVu System for use during the Acesa procedure. See the Acesa ProVu System User’s Guide (PI-01-0040) for additional information.

**Contraindication:**

The Acesa ProVu Handpiece Cable is contraindicated for use any time use of the Acesa System is contraindicated.

**Warnings:**

- The Acesa ProVu Handpiece Cable should be used only by physicians and medical staff who have been trained and have a thorough understanding of both the Acesa ProVu System.
- The Acesa ProVu Handpiece Cable is shipped non-sterile.

**Precautions:**

- Do not use if the product is damaged in any way.
- Refer to the Acesa ProVu System User’s Guide (PL-01-0040) for additional information on the set-up and use of the Acesa ProVu System.
- The Acesa ProVu Handpiece Cable has not been validated for more than 20 uses.

**Preparation and Operation:**

1. Remove the Acesa ProVu Handpiece Cable from its packaging.
2. Inspect cable for damage. Do not use if it appears to be damaged.
3. CLEAN & STERILIZE THE CABLE PRIOR TO EVERY USE.
4. Ensure that the cable & interconnections are completely dry prior to use.
5. See diagram below: Connect one end to the Acesa ProVu Handpiece and the other end to the Acesa ProVu Console with this icon: 
6. Ensure that there is a tactile feel when the connector latches or listen to the engaging click of the connector. Do the same for the Acesa ProVu Handpiece connector.
7. Follow any other instructions pertinent to the Acesa ProVu Handpiece being used.
8. To disconnect the cable, pull straight back on the connector sleeve (see Arrow icon) and then disconnect. DO NOT PULL ON CABLE.

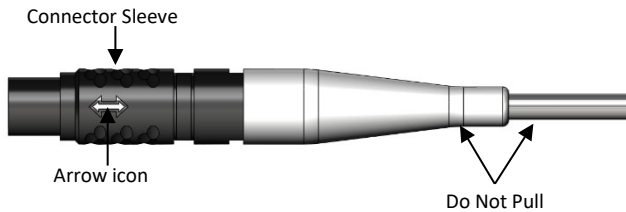

9. Store cable in a dry location.
10. See figure below for connections to the system.



**Recommended Cleaning and Sterilization**

Acesa Health recommends the following cleaning and sterilization steps as outlined below. Clean and sterilize the Acesa Handpiece Cable before first and every use. Acesa Handpiece Cables must be thoroughly cleaned, rinsed and dried according to the process described in this section before proceeding with sterilization of the device. Thorough cleaning and rinsing are the first and most important steps in the reprocessing of any reusable

medical device. Without thorough cleaning and rinsing, it is not possible to achieve effective sterilization of the device.

**Cleaning**

Rinse contact area of cable thoroughly with running water for two (2) minutes at 40°C (104°F), making sure all foreign matter, blood, mucus, etc. are removed with a debris removal tool. (ex. soft bristle brush, lint free cloth, sponge, etc.). Immerse device in an Enzymatic Cleaner with water at approximately 43°C (110°F) for three (3) minutes, while wiping and scrubbing cable and connectors with a debris removal tool.

*Follow the detergent manufacturer’s instructions for concentration and other conditions.*

Rinse with water for four (4) minutes at 40°C (104°F).

Dry with a lint free cloth.

Thoroughly examine all surfaces that have been cleaned and visually inspect the entire device to make sure it is clean.

**Table 1.** Recommended Manual Cleaning Durations

TREATMENT	TIME(MM:SS)	CLEANING SOLUTION
Rinse under running water with a debris removal tool ensuring all soil has been removed	02:00	Water 40°C (104°F)
Immerse device while wiping and scrubbing cable and connector with a debris removal tool.	03:00	Enzymatic Cleaner 43°C (110°F)
Rinse	04:00	Water 40°C (104°F)

**Sterilization**

The Acesa Handpiece Cable is provided non-sterile. The cable is sterilized using low-temperature hydrogen peroxide gas plasma technology, selected for its ability to process heat- and moisture-sensitive medical devices quickly, without producing toxic residues or emissions. The cable has been designed to be compatible with ASP STERRAD® 100NX, NX, and 100S systems, as well as STERIS V-PRO® systems.

*NOTE: Only one (1) Acesa Handpiece Cable should be run in a STERRAD® NX, 100S, or V-PRO® load at a time and No more than two (2) Acesa Handpiece Cables should be run in a STERRAD® 100NX load at a time.*

The following low-temperature hydrogen peroxide gas plasma sterilization cycles have been validated to result in a SAL of 10<sup>-6</sup> in accordance with applicable standards, including AAMI TIR12:

**Table 2.** Recommended Sterilization Cycles (STERRAD®)

STERILIZATION METHOD	PREPARATION*	STERRAD® STERILIZATION SYSTEM & CYCLE TYPE
Low-temperature Hydrogen Peroxide Gas Plasma Technology	Double wrap utilizing (inner wrap 500 grade, outer wrap 600 grade) FDA cleared Sterilization Wrap	STERRAD® Model 100NX Standard Cycle.
	Place into APTIMAX® Instrument Tray, PC:13837	STERRAD® Model NX Standard Cycle.
	Double wrap with H400 Sterilization Wrap, Halyard Health, PC:68248	STERRAD® Model 100S Short and Long Cycles.

\*Device preparation is based on the Acesa validated process. Reference appropriate STERRAD® model instructions for additional information or guidance.

**1.0 PURPOSE**

This specification has been written to document the Pad Cable Instructions for Use used with the Acessa System.

**2.0 SCOPE**

This IFU is placed into the Pad Cable package.

**3.0 PART DESCRIPTION**

3.1 8.5 x 11" white paper, 18-20 lb., tri-folded or equivalent.

3.2 Single Sheets.

3.3 Ink colors:  
Per sent file

**4.0 REQUIREMENTS**

4.1 Storage and Handling

Handle in a manner that will maintain the cleanliness of the material.

Shrink wrap in bundles of 50

4.2 Labeling Requirements

Acessa Health to label each container with part number and lot number prior to stock.

4.3 Languages:

4.3.1 English

**5.0 PRODUCT INSPECTION**

5.1 Inspect per Doc or PDF File.



## Acessa Pad Cable (Model Number 4300) Instructions for Use

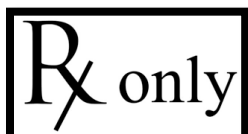

**CAUTION:** Federal Law (U.S) restricts this device to sale by or on the order of a physician trained in the use of the Acessa ProVu System for ablation of symptomatic uterine fibroids

### Product Description:

The Acessa Pad Cable provides connectivity between the Acessa Generator or Acessa ProVu System and Acessa Pads.

### Indications For Use:

The Acessa Pad Cable is an accessory to the Acessa Generator (Model 1000) or Acessa ProVu System (Model 7100) for use during the Acessa procedure.

### Contraindication:

The Acessa Pad Cable is contraindicated for use any time use of the Acessa Generator or Acessa ProVu System is contraindicated.



### Warnings:

- The Acessa Pad Cable should be used only by physicians and medical staff who have been trained and have a thorough understanding of the Acessa System.
- The Acessa Pad Cable is shipped non-sterile. Cleaning and disinfection is required before each use.

### Precautions:

- Do not use if the product is damaged in any way.
- Refer to the Acessa System User's Guide (PL-01-0016) or Acessa ProVu User's Guide (PL-01-0040) for additional information on the set-up and use of the Acessa Generator or Acessa ProVu System.
- The Pad cable has not been validated for more than 20 uses.

### Preparation and Operation:

- Remove the Pad Cable from its packaging.
- Inspect cable for damage. Do not use if it appears to be damaged.
- If using with Acessa Generator (Model 1000), now attach the Pad Cable to the port on the generator labeled with the product graphic. 
- If using Acessa ProVu System (Model 7100), now attach the Pad Cable (Model 4300) to the port on the Acessa ProVu Console labeled with the product graphic. 
- Connect one end of the cable to either the Acessa Generator or Acessa ProVu System Console, ensure that there is a tactile feel when the connector latches or listen to the engaging click of the connector.
- Connect the other end to the appropriate Left or Right Pad Cable connectors.
- Follow any other instructions pertinent to the use of the Acessa Generator or Acessa ProVu System.
- To disconnect the cable, pull straight back on the connector sleeve (see Arrow icon) and then disconnect. **DO NOT PULL ON CABLE.**

Connector Sleeve



- Store cable in a dry location.

### Recommended Cleaning and Disinfection Procedure:

Acessa Health recommends the following cleaning and disinfection steps as outlined below. All Acessa Pad Cables must be thoroughly cleaned, rinsed and dried according to the process described in this section before proceeding with disinfection of the device. Thorough cleaning and rinsing are the first and most important steps in reprocessing of any reusable medical device. Without thorough cleaning and rinsing, it is not possible to achieve effective disinfection of the device.

### Cleaning

Rinse contact area of cable thoroughly with running water for two (2) minutes at 40°C (104°F), making sure all foreign matter, blood, mucus, etc. are removed with a debris removal tool. (ex. soft bristle brush, lint free cloth, sponge, etc.).

Immerse device in an Enzymatic Cleaner with water at approximately 43°C (110°F) for three (3) minutes, while wiping and scrubbing cable and connectors with a debris removal tool.

*Follow the detergent manufacturer's instructions for concentration and other conditions.*

Rinse with water for four (4) minutes at 40°C (104°F).

Dry with a lint free cloth.

Thoroughly examine all surfaces that have been cleaned and visually inspect the entire device to make sure it is clean.

**Table 1.** Recommended Manual Cleaning Durations

TREATMENT	TIME(MM:SS)	CLEANING SOLUTION
Rinse under running water with a debris removal tool ensuring all soil has been removed.	02:00	Water 40°C (104°F)
Immerse device while wiping and scrubbing cable and connectors with a debris removal tool.	03:00	Enzymatic Cleaner 43°C (110°F)
Rinse	04:00	Water 40°C (104°F)

### Disinfection

Spray the devices with CIDEX (or equivalent), while ensuring the entire surface comes in contact with the disinfectant.

*The contact time, according to the manufacturer of CIDEX, is a minimum of three (3) minutes.*

After three (3) minutes of contact time, the devices are rinsed with sterile water for three (3) minutes at 40°C (104°F) and allowed to air dry.

*Follow the disinfectant manufacturer's instructions for procedure and immersion times.*

Wear sterile gloves and rinse off the disinfectant thoroughly with sterile water.

Dry with a sterile cloth.

Examine for damage. Discontinue use if the cable is damaged

**Table 2.** Recommended Manual Disinfection Durations

TREATMENT	TIME (MM:SS)	DISINFECTION SOLUTION
Spray the entire surface of the device and allow to rest	03:00	CIDEX (or equivalent)
Rinse	03:00	Water 40°C (104°F)
Rinse	03:00	Sterile Water 40°C (104°F)



**MANUFACTURER:** Acesa Health Inc.  
317 Grace Ln, Suite 200  
Austin, TX 78746 USA

www.acesaprocedure.com  
Telephone: 877.412.3828; Fax: 925.605.0327

Acesa is a trademark of Acesa Health Inc.  
Copyright 2018, Acesa Health Inc.  
U.S. and Foreign Patents Pending

**Glossary of Symbols**

SYMBOL	STANDARD REFERENCE	SYMBOL TITLE/DESCRIPTION
	US 21 CFR 801.109	<b>Prescription Only</b> / Device restricted to use by or on the order of a physician.
	ISO 15223-1:2016 5.1.5	<b>Lot Identification</b> / Indicates the manufacturer's batch code so that the batch or lot can be identified.
	ISO 15223-1:2016 5.1.1	<b>Manufacturer</b> / Indicates the medical device manufacturer.
	ISO 15223-1:2016 5.1.6	<b>Catalogue or Model Number</b> / Indicates the manufacturer's catalogue number so that the medical device can be identified.
	IEC 60601-1:2012 Table D.2Symbol 10	<b>Follow Instructions for Use</b> / Refer to instruction manual/booklet.
	ISO 15223-1:2016 5.2.7	<b>Non-sterile</b> / Sterilize Prior to Use (manufacturer does not provide this device sterile)