



Faxitron[™] Path+ Specimen Radiography System

**Bigger is Better.
Optimized imaging of your largest
specimens.**

With no larger field of view available in the pathology market, and combined with one of the best-in-class resolution detectors, the Faxitron Path+ system helps deliver greater efficiency for the gross lab and more timely results for the patient.

Faxitron[™] Path+ Specimen Radiography System



High-resolution Imaging

Faxitron Path+ system's multiple levels of geometric magnification (up to 10X) allow you to image full term fetuses down to the smallest microcalcifications, all at one of the highest resolution in the market.



Large Field of View

The system's large chamber and detector size accommodate a broad range of samples without sacrificing image quality. This allows the user to image intact mastectomies to femurs to full-term fetal remains, all directly in the lab.



Easy to Use

Intuitive software is easily interfaced with PACS (if available) and multiple image file formats are available for a variety of digital pathology and information systems. No specialized x-ray training is required or needed.

Technical Specifications

There is no larger imaging area on the market than the Faxitron Path+ System. It doesn't sacrifice resolution allowing you to identify the smallest micro-calcifications while being the only system in its class to have 510(k) clearance. From breast tissue slices to intact mastectomies, bones to fetal remains, the 43 x 43cm CMOS detector accommodates them all.

Specifications	
Imaging area	43cm x 43cm (17" x 17")
Pixel pitch	100µm (18.7 million pixels)
Scintillator	Direct deposited CsI
Magnification	Up to 10 times
Spatial resolution	10µm at magnification (up 50+ lp/mm)
Energy range	20-100kv
Max tube current	0.5mA (limited to 12W)
Focal spot size	8µm- 15µm (power dependent)
Tube filtration	0.25mm Be, tungsten source
Power requirements	100-240VAC, 50/60Hz
External dimensions	34" W x 31" D x 62" H (86cm x 79cm x 158cm)
Chamber dimensions	25" W x 25" D x 36" H (64cm x 64cm x 92cm)
Weight	1,400lbs (635kg)

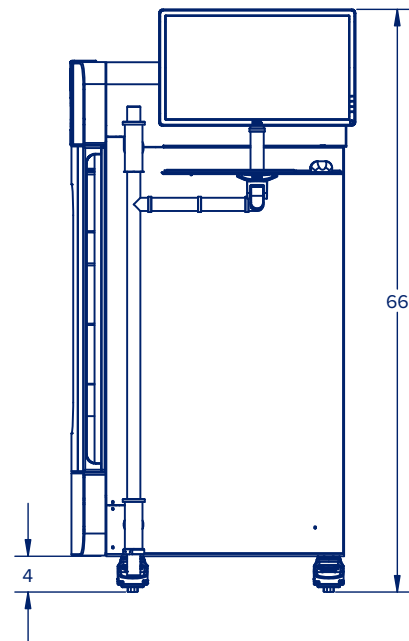
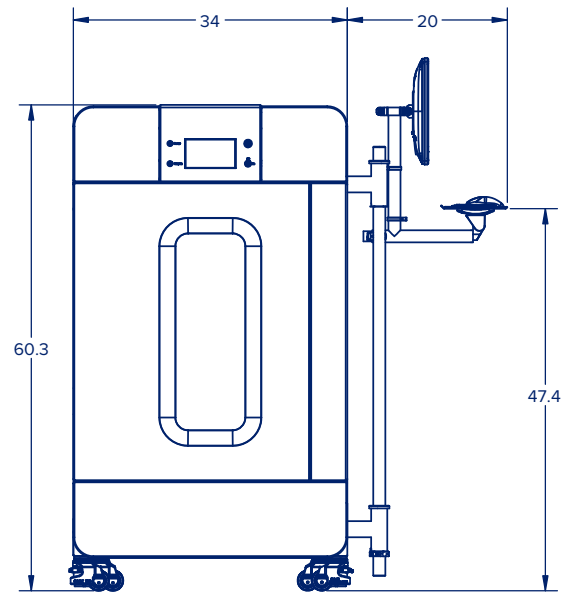

Faxitron™ Path+ system also known as PathVision™ XL System.

www.hologic.com | BSHInsideSales@hologic.com | +1.800.442.9892